

TWO POST LIFT INSTALLATION AND OWNERS MANUAL

Capacity 10,000 lbs.

May 2010

IN60010

C07564.2 Rev. A

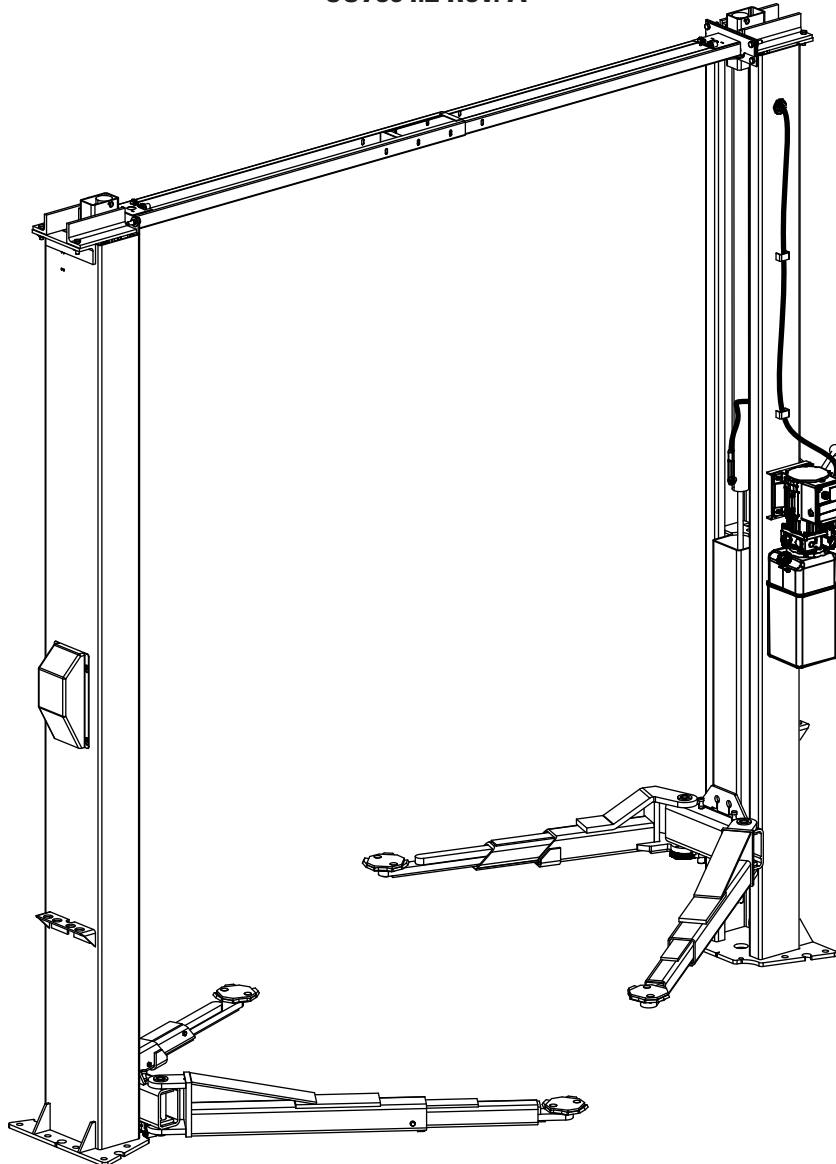

▲ IMPORTANT Reference ANSI/ALI ALIS,
Safety Requirements for
Installation and Service of Automotive Lifts
before installing lift.

TABLE OF CONTENTS

Section 1 Owner's Manual

Safety Instructions	3
Monthly Maintenance	4
Troubleshooting	5
Lift Lockout/Tagout Procedure	7
Operating Conditions	7

Section 2 Installation Instructions

Tools Required for Installation.....	8
Procedure	8

Section 3 Parts Breakdown

Detailed Views & Parts List.....	25
----------------------------------	----

Important Information:

1. Read this manual thoroughly before installing, operating, or maintaining this lift.
2. This lift is designed for indoor use only, and should not be installed in a pit or depression.
3. The floor on which the lift is to be installed must be 4-¼" inch minimum thickness concrete, with a minimum compressive strength of 3000 psi, and reinforced with steel bar.
4. The lifts have specific electrical requirements as described in the Installation Instructions section of this manual.
5. This lift has a minimum ceiling height requirement as described in the Installation Instructions section of this manual.
6. Failure by the owner to provide the recommended shelter, mounting surface, electrical supply, and ceiling height could result in unsatisfactory lift performance, property damage, or personal injury.

Section 1

Owner's Manual

Safety Instructions:

1. **Do not raise a vehicle on the lift until the installation is completed as described in this manual.**
2. **Anyone who will be in the vicinity of the lift** when it is in use should read and refer to the following publications supplied with this lift:
 - "INSTALLATION AND OWNERS MANUAL", I MAN 994322
 - "LIFTING IT RIGHT", ALI SM93-1.
 - "AUTOMOTIVE LIFT SAFETY TIPS", ALI-ST90.
 - "VEHICLE LIFTING POINTS FOR FRAME ENGAGING LIFTS", ALI/LP-GUIDE.
 - "SAFETY REQUIREMENTS FOR OPERATION, INSPECTION, AND MAINTENANCE", ANSI/ALI ALOIM-2006.
3. **Technicians** should be trained to use and care for the lift by familiarizing themselves with the publications listed above. The lift should never be operated by an untrained person.
4. **Always position the arms and adapters properly out of the way** before pulling the vehicle into, or out of the bay. Failure to do so could damage the vehicle and/or the lift.
5. **Do not overload the lift.** The capacity of the lift is shown on cover of this document and on the lift's serial number tag.
6. **Positioning the vehicle** is very important. Only trained technicians should position the vehicle on the lift. Never allow anyone to stand in the path of the vehicle as it is being positioned.
7. **Position the arms to the vehicle manufacturer's recommended pickup points.** Raise the lift until contact is made with the vehicle. Make sure that the arms have properly engaged the vehicle before raising the lift to a working height.
8. **Keep everyone clear of the lift when the lift is moving, the locking mechanism is disengaged, or the vehicle is in danger of falling.**
9. **Unauthorized personnel** should never be in the shop area when the lift is in use.
10. **Inspect the lift daily.** The lift should never be operated if it has damaged components, or is malfunctioning. Only qualified technicians should service the lift. Replace damaged components with manufacturer's parts, or equivalent.
11. **Keep the area around the lift clear** of obstacles.
12. **Never** override the self-returning lift controls.
13. **Use safety stands** when removing or installing heavy vehicle components.
14. **Avoid excessive rocking** of the vehicle when it is on the lift.
15. **To reduce the risk of personal injury**, keep hair, loose clothing, fingers, and all body parts away from moving parts.
16. **To reduce the risk of electric shock**, do not use the lift when wet, do not expose the lift to rain.
17. **To reduce the risk of fire**, do not operate equipment in the vicinity of open containers of flammable liquids (gasoline).
18. **Use the lift only as described in this manual**, use only manufacturer's recommended attachments.
19. Unusual vehicles, such as limousines, RV's, and long wheelbase vehicles, may not be suitable for lifting on this equipment. If necessary, consult with the manufacturer or the manufacturer's representative.
20. The troubleshooting and maintenance procedures described in this manual can be done by the lift's owner/employer. Any other procedure should only be performed by trained lift service personnel. These restricted procedures include, but are not limited to, the following: cylinder replacement, carriage and safety latch replacement, leg replacement, overhead structure replacement.
21. **Anyone who will be in the vicinity of the lift** when it is in use should familiarize themselves with following Caution, Warning, and Safety related decals supplied with this lift, and replace them if the are illegible or missing:

<p>CAUTION</p> <p>Lift to be used by trained operator only.</p>	<p>CAUTION</p> <p>Authorized personnel only in lift area.</p>
--	--

<p>WARNING</p> <p>Clear area if vehicle is in danger of falling.</p>	<p>WARNING</p> <p>Position vehicle with center of gravity midway between adapters.</p>
---	---

<p>CAUTION</p> <p>Use vehicle manufacturer's lift points.</p>	<p>CAUTION</p> <p>Always use safety stands when removing or installing heavy components.</p>
--	---

<p>WARNING</p> <p>Remain clear of lift when raising or lowering vehicle.</p>	<p>WARNING</p> <p>Avoid excessive rocking of vehicle while on lift.</p>
---	--

<p>CAUTION</p> <p>Use height extenders when necessary to ensure good contact.</p>	<p>CAUTION</p> <p>Auxiliary adapters may reduce load capacity.</p>
--	---

<p>WARNING</p> <p>Do not override self-closing lift controls.</p>	<p>WARNING</p> <p>Keep feet clear of lift while lowering.</p>
--	--

SAFETY INSTRUCTIONS

Read operating and safety manuals before using lift.

SAFETY INSTRUCTIONS

Proper maintenance and inspection is necessary for safe operation.

SAFETY INSTRUCTIONS

Do not operate a damaged lift.

The messages and pictographs shown are generic in nature and are meant to generally represent hazards common to all automotive lifts regardless of specific style.

Funding for the development and validation of these labels was provided by the Automotive Lift Institute, PO Box 33116 Indialantic, FL 32903-3116.

They are protected by copyright. Set of labels may be obtained from ALI or its member companies.

© 1992 by ALI, Inc. ALI/WL101s

The messages and pictographs shown are generic in nature and are meant to generally represent hazards common to all automotive lifts regardless of specific style.

Funding for the development and validation of these labels was provided by the Automotive Lift Institute, PO Box 33116 Indialantic, FL 32903-3116.

They are protected by copyright. Set of labels may be obtained from ALI or its member companies.

© 1992 by ALI, Inc. ALI/WL101s

The messages and pictographs shown are generic in nature and are meant to generally represent hazards common to all automotive lifts regardless of specific style.

Funding for the development and validation of these labels was provided by the Automotive Lift Institute, PO Box 33116 Indialantic, FL 32903-3116.

They are protected by copyright. Set of labels may be obtained from ALI or its member companies.

© 1992 by ALI, Inc. ALI/WL101w

Monthly Maintenance:

1. Lubricate the four inside corners of the legs with heavy duty bearing grease.
2. With lift lowered check the hydraulic fluid level. If necessary add oil as described in the Installation Instruction section of this manual
3. Check carriage latch synching: Latches should click at the same time. If necessary adjust equalization cables as described in the Installation Instruction section of this manual.
4. Check tightness of all bolts.
5. Check anchor bolt tightness. If the anchor bolts are loose, they should be re-torqued to 90ft/lbs.
 - Check the nuts for tightness every week for the first month, and every month afterwards.
6. Replace worn or broken parts with lift manufacturer's parts, or their equivalent.

Troubleshooting:

7. The power unit does not run:
 - Check electrical supply breaker, or fuse.
 - Check for activation of the travel limit switch by a tall vehicle.
 - Check micro-switch and connections in motor control box.
 - Check voltage to the motor.
 - Check micro-switch and connections in the overhead switch box.
8. The power unit runs but does not raise the lift:
 - Check the oil level.
 - Check that the lowering valve is not stuck open.
 - Check the connections and components on the suction side of the pump.
9. The power unit raises the lift empty, but will not lift a vehicle.
 - Make sure the vehicle is not above the rated capacity of the lift.
 - Make sure the vehicle is positioned properly.
 - Clean the lowering valve by running the power unit for 30 seconds while holding the lowering valve open.
 - Check the motor voltage.
10. Lift drifts down.
 - Check for external leaks.
 - Clean the lowering valve by running the power unit for 30 seconds while holding the lowering valve open. Repeat this procedure three times.
 - Clean the check valve seat.
11. Slow Lifting and/or oil foaming up.
 - Check that oil used meets the specification in the Installation Instruction section of this manual.
 - Tighten all suction line fittings.
12. Anchors continually work loose
 - If holes were drilled too large relocate the lift per the Installation Instruction section of this manual.
 - Floor is not sufficient to provide the necessary resistance, remove an area of concrete and re pour as described in the Installation Instruction section of this manual.
13. Lift does not raise and lower smoothly.
 - Reposition vehicle for a more even weight distribution.
 - Check the four inside corners of the two legs for roughness. Any rust or burrs must be removed with 120 grit emery cloth.
 - Lubricate the leg corners with heavy duty bearing grease.
 - Use a level to check the legs for vertical alignment both side to side and front to back. Shim the legs as necessary per the Installation Instruction section of this manual.
 - Check the oil level.
 - Make sure there is no air in the hydraulic lines, bleed system as described in the Installation Instruction section of this manual.
14. The lift will only lower approximately 1", then stops.
 - Check that the safety latches are disengaged.

15. At full rise the latch will not disengage and the lift cannot be lowered.
- If the equalization cables are out of adjustment the carriages are out of sync, and when the lift is at full rise one of the safety latches may not have the clearance to disengage and allow the lift to lower.
 - * To lower the lift
 - » Raise the lift to full height.
 - » Make sure both latches are engaged.
 - » Use a hydraulic jack and a length of pipe to raise the carriage with the lock which is sticking enough to disengage the safety latch.
 - » Remove the jack and pipe.
 - » Pull the latch release handle to disengage the latches.
 - » Lower the lift and remove the vehicle.
 - » Readjust the cables as described in the Installation Instruction section of this manual.
16. Power Unit will not stop running
- Switch is damaged, **turn off power to the lift** and replace switch.

6. Lift Lockout/Tagout Procedure

Purpose

This procedure establishes the minimum requirements for the lockout of energy that could cause injury to personnel by the operation of lifts in need of repair or being serviced. All employees shall comply with this procedure.

Responsibility

The responsibility for assuring that this procedure is followed is binding upon all employees and service personnel from outside service companies (i.e., authorized installers, contractors, etc.). All employees shall be instructed in the safety significance of the lockout procedure by the facility owner/manager. Each new or transferred employee along with visiting outside service personnel shall be instructed by the owner/manager (or assigned designee) in the purpose and use of the lockout procedure.

Preparation

Employees authorized to perform lockout shall ensure that the appropriate energy isolating device (i.e., circuit breaker, fuse, disconnect, etc.) is identified for the lift being locked out. Other such devices for other equipment may be located in close proximity of the appropriate energy isolating device. If the identity of the device is in question, see the shop supervisor for resolution. Assure that proper authorization is received prior to performing the lockout procedure.

Sequence of Lockout Procedure

- 1) Notify all affected employees that a lockout is being performed and the reason for it.
- 2) Unload the subject lift. Shut it down and assure the disconnect switch is "OFF" if one is provided on the lift.
- 3) The authorized lockout person operates the main energy isolation device removing power to the subject lift.
 - If this is a lockable device, the authorized lockout person places the assigned padlock on the device to prevent its unintentional reactivation. An appropriate tag is applied stating the person's name, at least 3" x 6" in size, an easily noticeable color, and states not to operate device or remove tag.
 - If this device is a non-lockable circuit breaker or fuse, replace with a "dummy" device and tag it appropriately as mentioned above.
- 4) Attempt to operate lift to assure the lockout is working. Be sure to return any switches to the "OFF" position.
- 5) The equipment is now locked out and ready for the required maintenance or service.

Restoring Equipment to Service

- 1) Assure the work on the lift is complete and the area is clear of tools, vehicles, and personnel.
- 2) At this point, the authorized person can remove the lock (or dummy circuit breaker or fuse) & tag and activate the energy isolating device so that the lift may again be placed into operation.

Rules for Using Lockout Procedure

Use the Lockout Procedure whenever the lift is being repaired or serviced, waiting for repair when current operation could cause possible injury to personnel, or for any other situation when unintentional operation could injure personnel. No attempt shall be made to operate the lift when the energy isolating device is locked out.

7. Operating Conditions

Lift is not intended for outdoor use and has an operating ambient temperature range of 41°-104°F (5°-40°C).

Section 2 Installation Instructions

Tools required for installation:

- Concrete hammer drill with 3/4" bit
- 11/16" open end wrench
- 3/4" open end wrench
- Torque wrench
- 15/16" deep socket or wrench
- 1-1/8" socket
- 13/16" open end wrench
- Level (18" minimum length)
- Vise grips
- Tape measure
- Funnel
- Hoist or Forklift (optional)
- Two 12' step ladders
- 1/4" drive ratchet with 5/16" socket

Procedure:

1. Read this manual thoroughly before installing, operating, or maintaining this lift.
2. **Site Evaluation and Lift Location:**
 - A. Always use an architect's plan when provided. Before unpacking the lift entirely, determine if the site is adequate for the lift model being installed see figures 1 and 2 for typical bay layout and ceiling height requirements.
 - B. Snap chalk lines to identify the lift's centerline.
 - C. Snap a chalk line parallel to the lift's centerline, spaced 9" toward the rear of the bay. This line represents the back edge of the leg bases.
 - D. Snap chalk lines parallel to the lift's centerline spaced 68-1/2 to the left and 68-1/2 to the right. These lines represent the APPROXIMATE outside edges of the leg bases,

* DO NOT USE THESE LINES TO POSITION THE LEGS, FOLLOW THE INSTRUCTIONS IN THIS MANUAL.

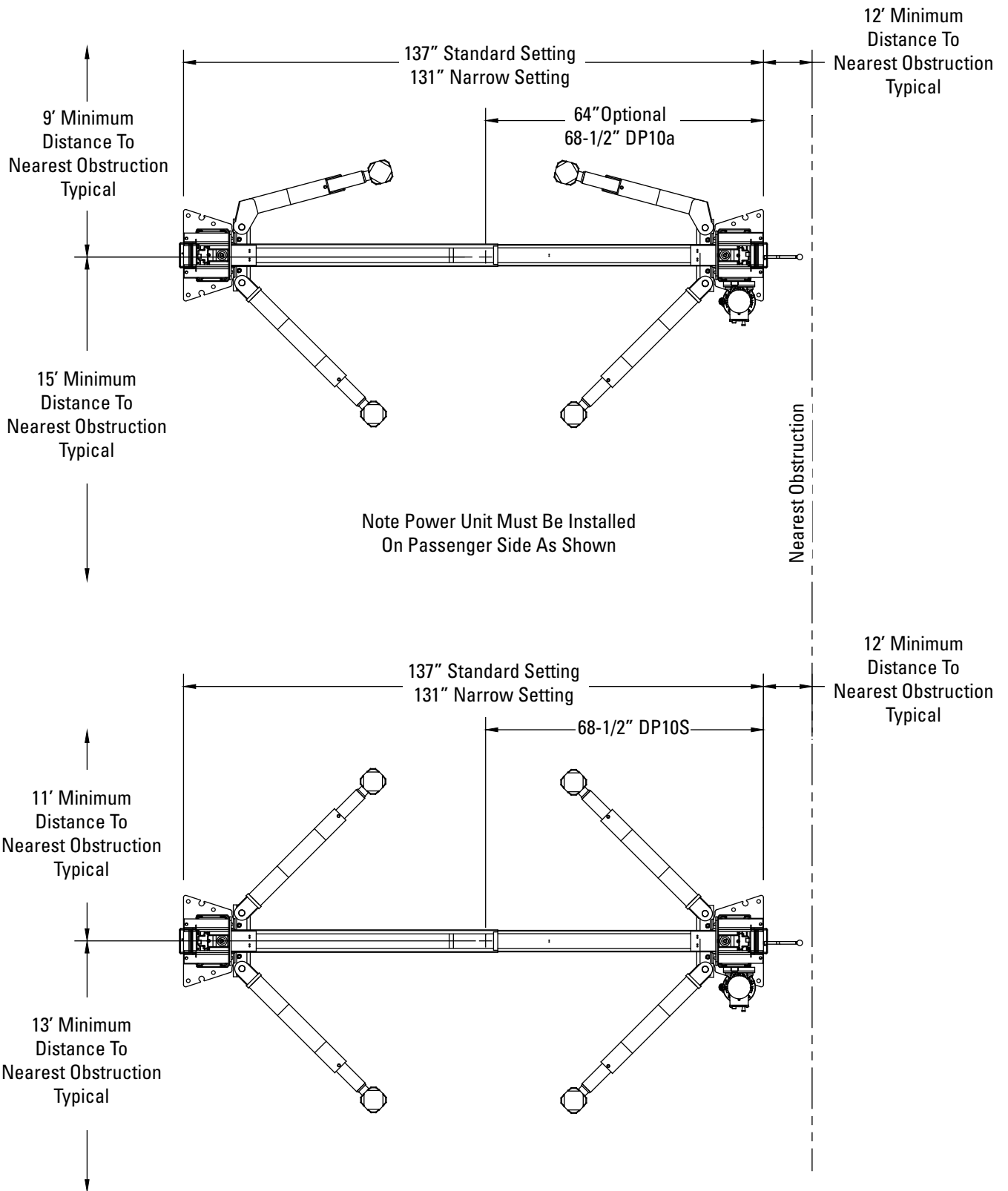

Figure 1

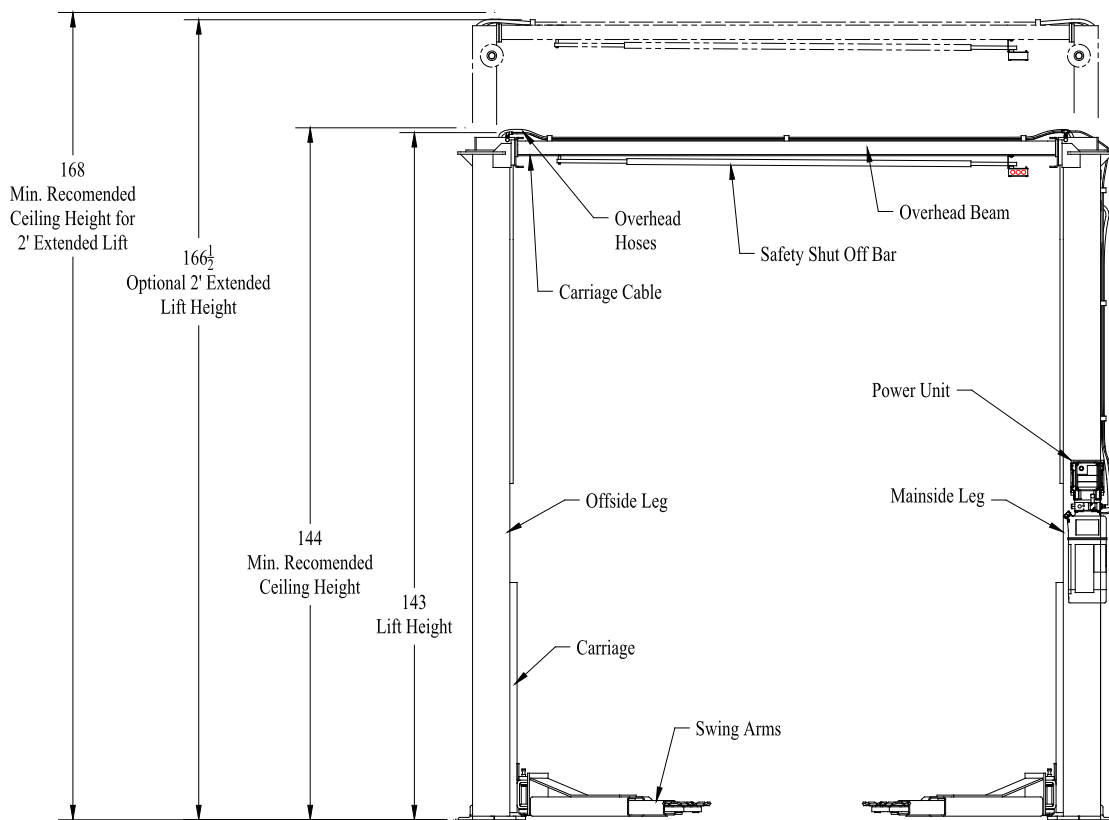

Figure 2

3. Unpack the lift. Remove the swing arms, bolt box, power unit box, and overhead beam.
 - A. Save all packing hardware, as these components are necessary to complete the installation.
 - B. Remove the $\frac{1}{2}$ " bolts from the uprights which hold the two legs together.
 - C. Remove the top leg. Do not stand legs up, instead lay the legs flat on their backs on the floor.

4. Attach the cylinder mount or uprights. Attach the cylinder mounts or uprights to the legs using four $\frac{1}{2}$ " X $1\text{-}\frac{3}{4}$ " bolts, washers and nuts as shown in figure 3a. Assemble overhead beam using (2) M10 x 1.5 bolts and M10 serrated flanged lock nuts, figure 3.

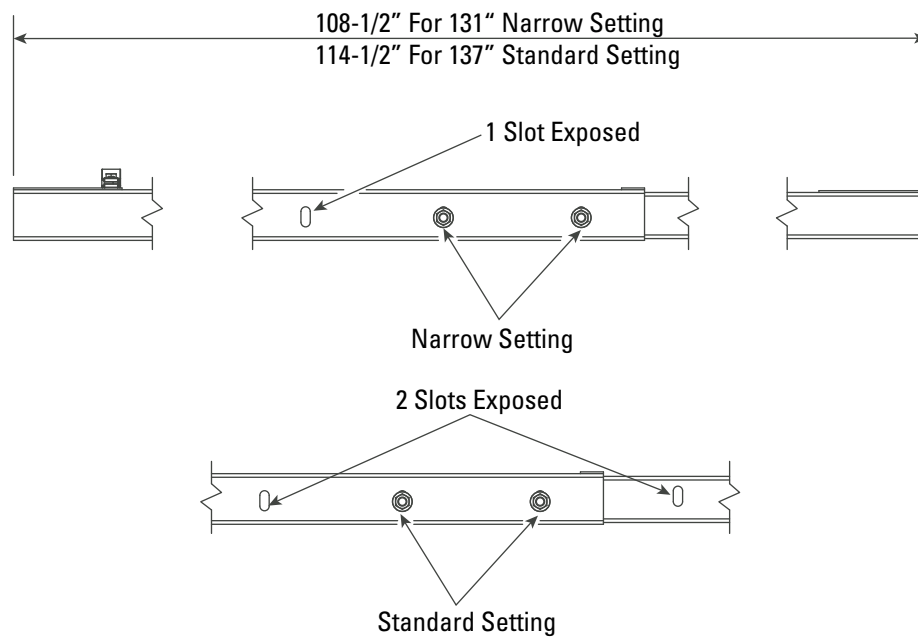

Figure 3

5. **Install hydraulic cylinders, fittings, hoses, and cables**

A. **Warning:** When attaching hydraulic fittings with pipe threads to the cylinders use Teflon tape. **DO NOT start the Teflon tape closer than 1/8" from the end of the fitting.** Failure to comply may cause damage to the hydraulic system.

B. **Warning:** When tightening connections with flared (JIC) fittings, always follow the following tightening instructions. Failure to follow these instructions may result in cracked fittings and / or leaks.

- * Use the proper size wrench,
- * The nut portion of the fitting is the only part that should turn during tightening. The flare seat **MUST NOT** turn.
- * Screw the fittings together hand tight.
- * Use the proper size wrench to rotate the nut portion of the fitting 2-1/2 hex flats.
- * Back the fitting off one full turn.

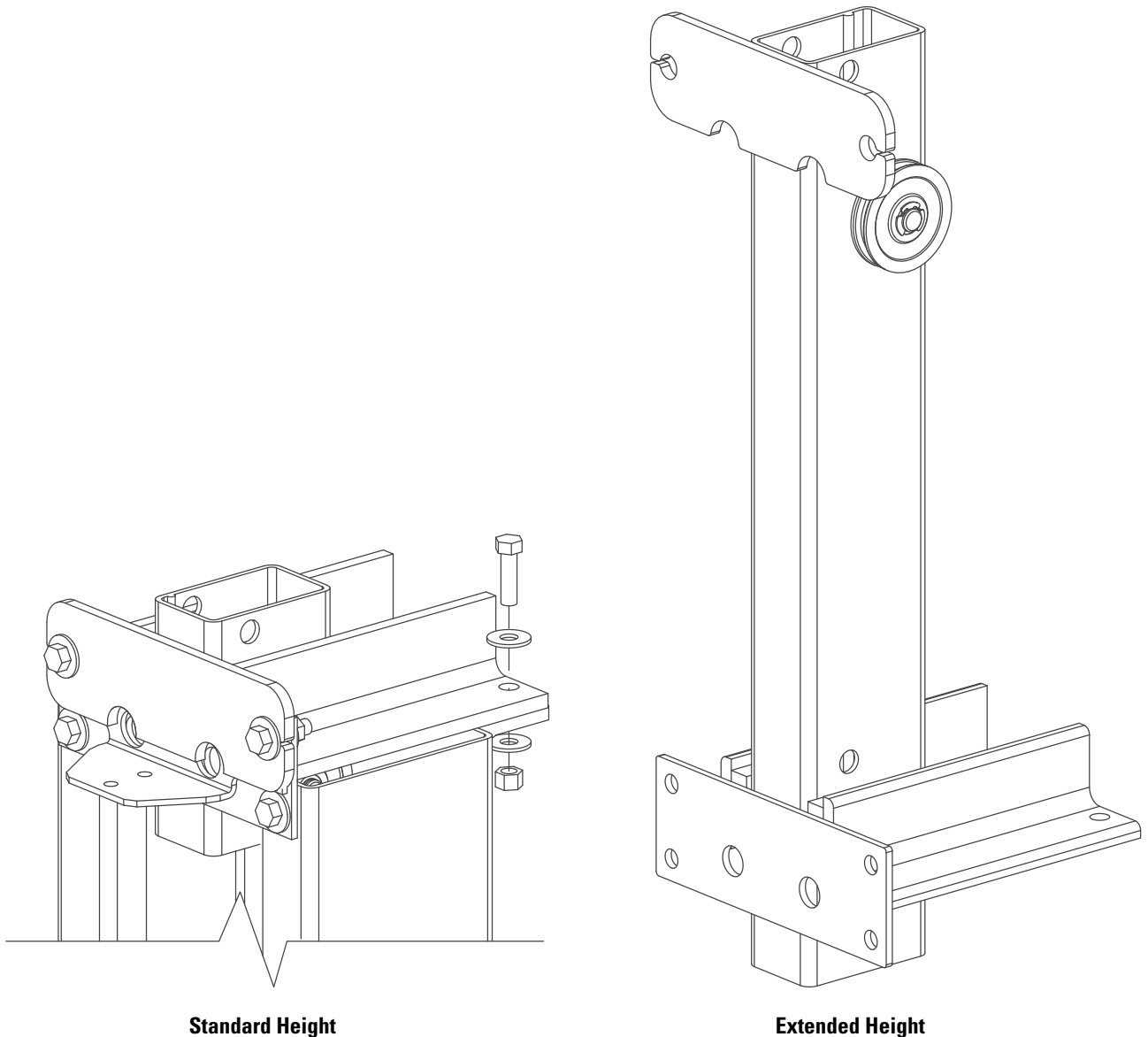

Figure 3a

* Again, tighten the fitting hand tight, then rotate the nut portion of the fitting 2-1/2 hex flats.

- C. Install the cylinders to the uprights with 1/2" x 5" Grade 8 bolt, **cylinder bushings**, washers, and nut, Figure 4. The port near the rod end of the cylinders should be positioned pointing to the leg's open side.
- D. Remove the plugs and install the bushings into the ports at the top of the cylinders.
- E. Connect the shortest hydraulic hose to one of the runs on the JIC tee fitting.
- F. Connect the longest hydraulic hose to the other run on the JIC tee fitting.
- G. Connect the remaining hydraulic hose to the branch on the JIC tee fitting.
- H. Install the rubber grommet into the hole in the mainside leg.
- I. Connect a male pipe thread to male JIC elbow to the port near the rod end of each cylinder. The fittings should face towards the center of the lift.
- J. Connect the free end of the shortest hydraulic hose to the elbow on the cylinder in the mainside leg. This connection should be hand-tight only.
- K. Feed the shortest remaining hose through the rubber grommet, from inside the leg out. Feed this hose down through the hose guide welded to the outside of the leg. This hose will attach to the power unit.

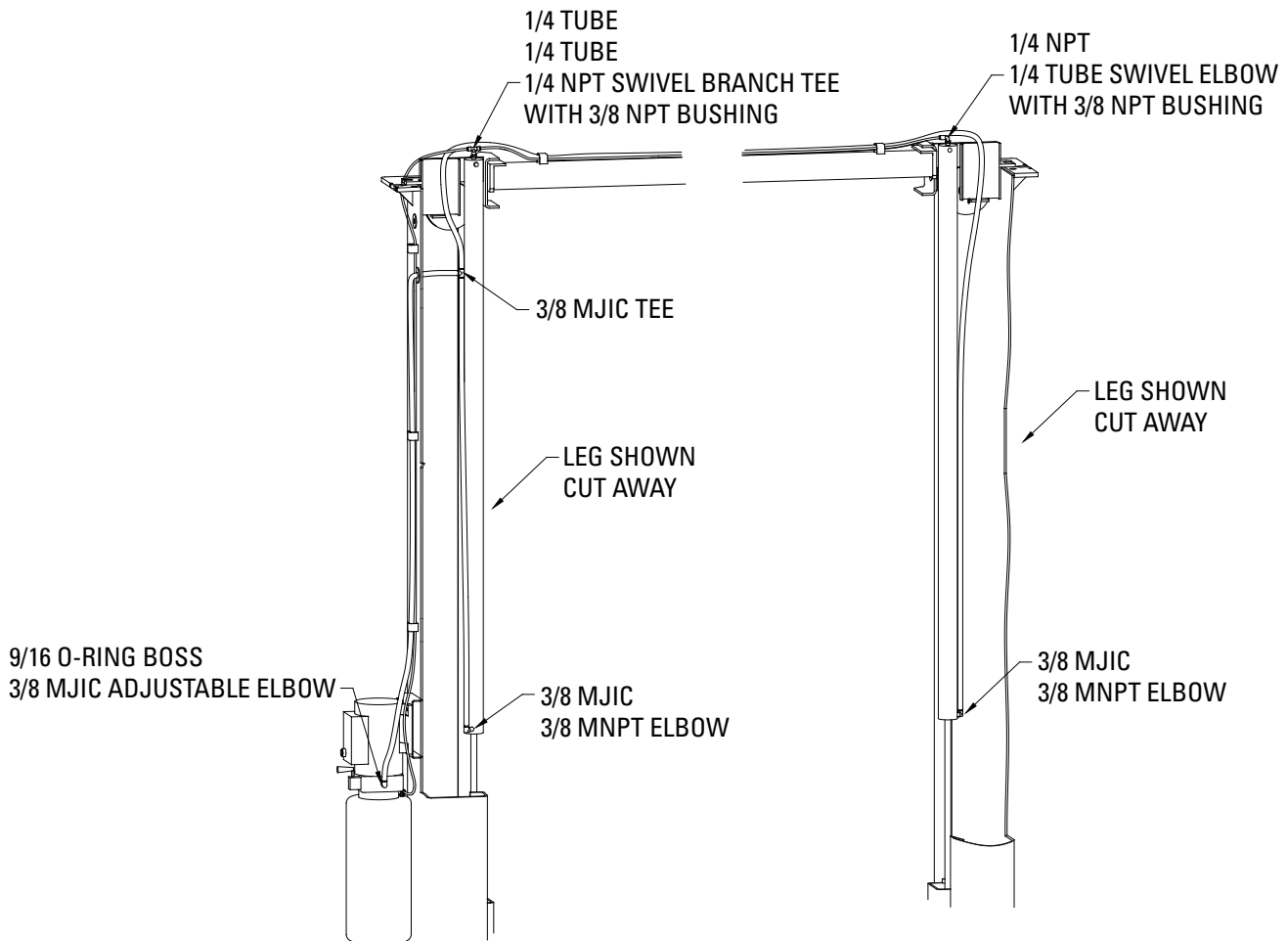

Figure 4

- L. Feed the long hose through the cylinder mount or upright tube along the cylinder and out the end.
- M. Connect push in connectors to the base port of each cylinder. The tee should be attached to the main side cylinder.
- N. Feed one end of an equalization cable down through the rightmost hole in the carriage top, figure 5. Continue to feed the cable until it extends out the bottom of the carriage. Attach a nylon insert locknut and washer to the end of the cable so that 1/8" of cable stud extends past the end of nut. Pull the opposite end of the cable until the washer contacts the carriage top. Repeat for the other cable/carriage.

Note: For narrow setting, use cable attachment further down inside carriage.

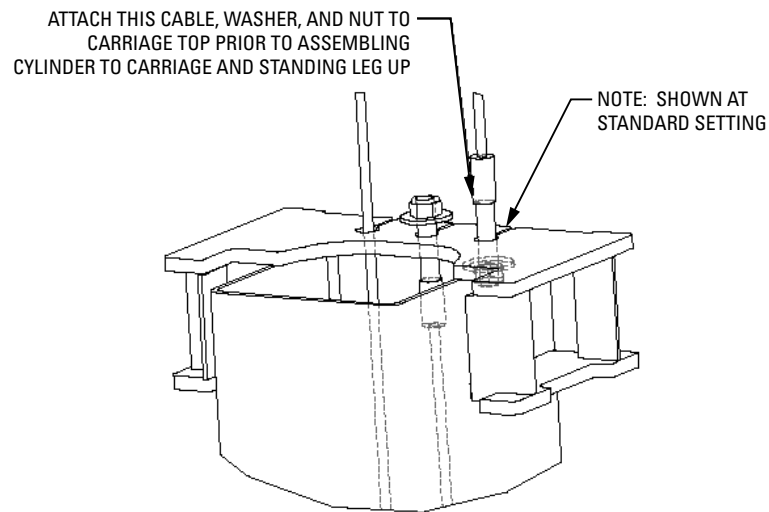

Figure 5

- O. Attach the cylinders to the carriages. Make sure the snap ring on the cylinder rod is in the groove. Taking care not to damage the threads on the cylinder rod, pull carriage up to the cylinder and feed the rod through the hole in the carriage plate until the snap ring contacts it. Attach the full nut to the rod and tighten until the cylinder rod turns. Hold the full nut with a wrench and tighten a jam nut against it. Repeat for the other cylinder.
 - * **Do not hold the cylinder rod in a way that could damage the finish. Cylinder leaks caused by damaged rods are not covered by warranty.**
- 6. **Carriage Placement.** Disengage the latch by pulling out the latch on the column, figure 6. Slide the carriage to the leg's baseplate. Engage the latch by releasing the latch. Slide the carriage up until the first "click" is heard. Repeat the process for the other carriage.

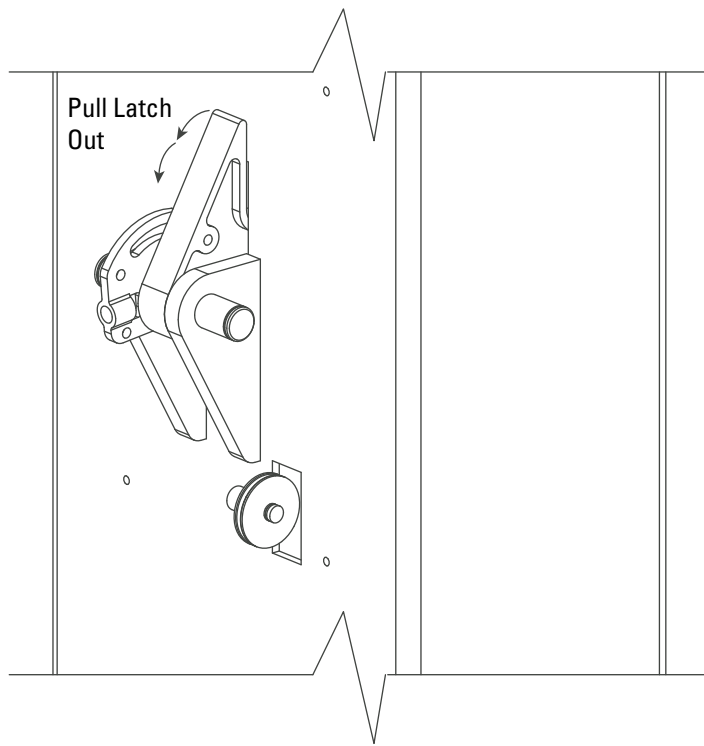

Figure 6

7. Leg positioning and anchoring

- A. **Raise the Mainside leg only** and position it where it is to be secured, figure 2.
- B. The anchor bolts must be installed at least 5-11/16" from any edge or seam in the concrete
- C. The concrete must be at least 4-1/4" thick with a compressive strength of 3,000 psi.
- D. Using the leg as a template, drill the anchor bolt holes for the **Mainside Leg Only!!**
 - * Use a hammer drill with a Carbide tip, 3/4" diameter, solid drill bit. The bit tip diameter should be to ANSI Standard B95.12-1977. (.775" to .787").
 - * Keep the drill perpendicular to the floor while drilling.
 - * Let the drill do the work. Do not apply excessive pressure.
 - * Lift the drill up and down to remove dust and reduce binding.
 - * Drill the hole completely through the slab.
 - * Clean the dust from the hole.

- E. Assemble the washers and nuts onto the anchor bolts. Thread the nuts onto the anchor bolts where the tops of the nuts are just above the top of the bolts, figure 7. Using a hammer, carefully tap the anchor bolts into the concrete until the washer rests against the baseplate. Do not damage the nuts or threads.

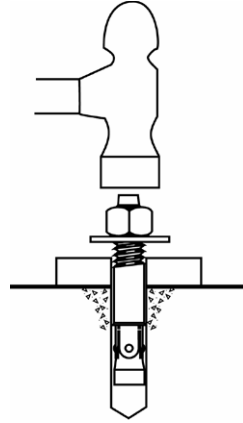

Figure 7

- F. Using a level, plumb the mainside leg both side to side and front to back. Shim the leg as necessary next to and on both sides of the anchor bolts, figure 8. If more than 1/2" of shimming is required, do not use the anchors and shims provided with the lift. Use longer anchors and fabricate larger shims from steel flat, 1/4" or 1/2" thick by 2", or more, wide.

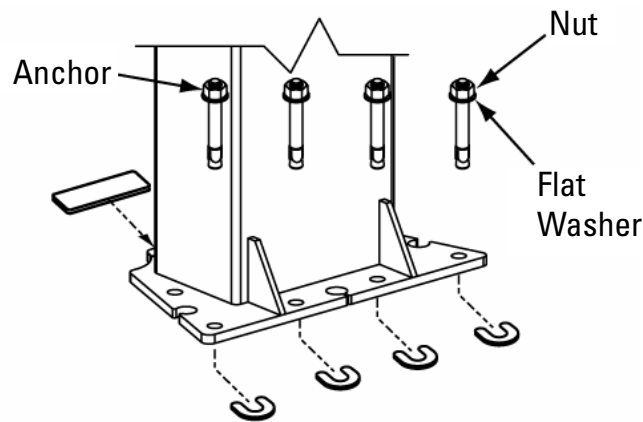

Figure 8

- G. Once the leg is plumb tighten the anchor bolts to 150 ft-lbs. Do not use an impact wrench on anchor bolts.
- * If after tightening the anchor supplied with the lift extends more than 2-1/4" above the floor the anchor does not have enough embedment.
 - * If an anchor will not reach 150 ft-lbs or does not have enough embedment or adequate spacing cannot be achieved, replace the concrete under the leg with a 4' X 4' X 6" thick pad of 3,000 psi concrete keyed under the existing floor. Let the concrete cure before reinstalling the lift.

- H. Recheck the leg's plumbness after tightening the anchor bolts. Add shims if necessary.
 - I. Raise the offside leg and position it where it is to be located, figure 2. **Do not drill holes for anchors.**
8. **Overhead assembly**

A. **Single Phase Instructions.**

- * Using (2) 1/4"-20 X 1/2" HHCS and (2) 1/4"-20 Flange Lock Nuts attach the overhead switch assembly to the overhead beam as shown in figure 9.

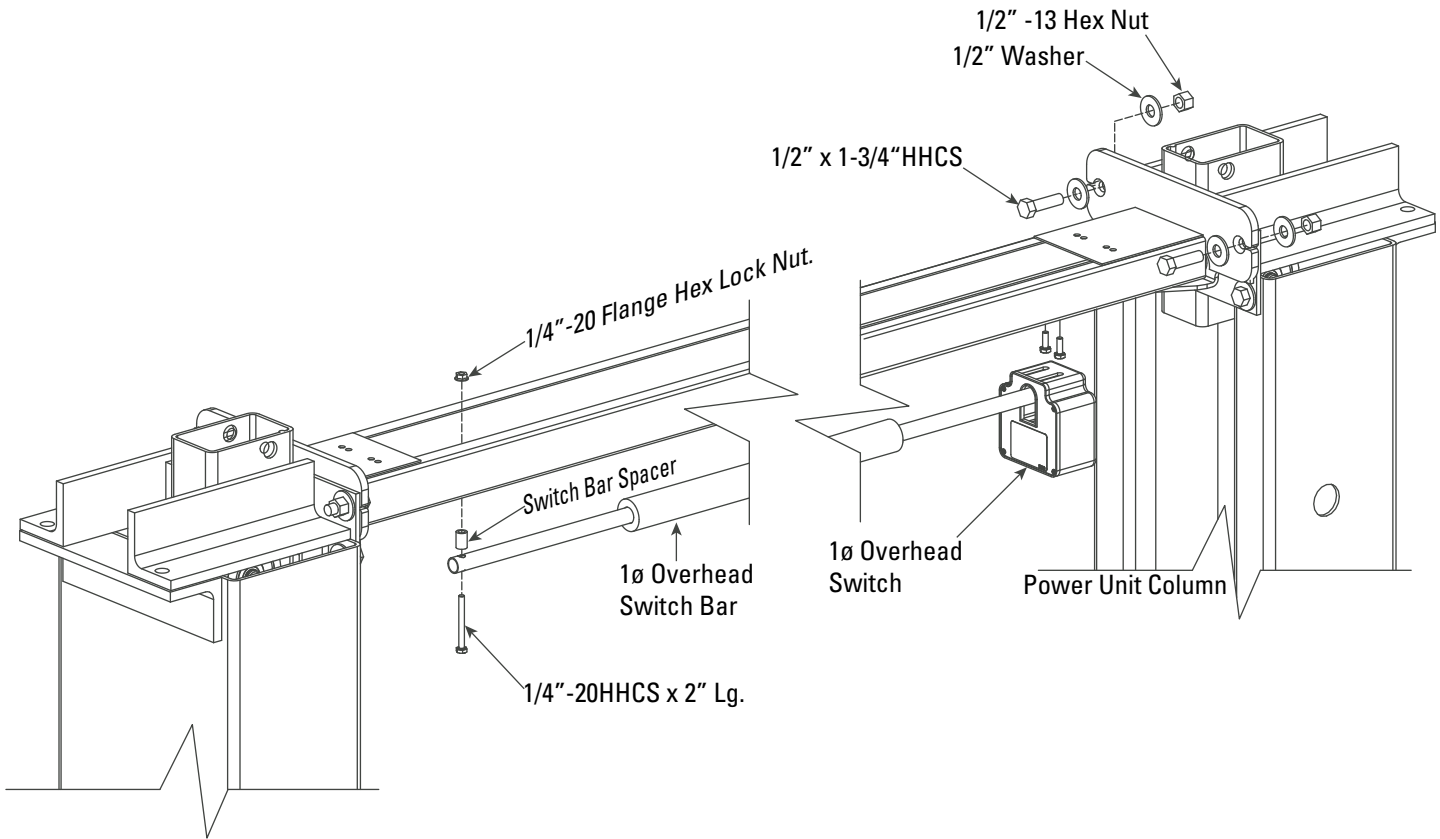

Figure 9

- * Slide the end of the padded switchbar without a mounting hole in it through the slot in the overhead switch assembly. Connect the padded switchbar to the inside hole in the overhead beam using a cylindrical spacer, 1/4"-20 X 1-3/4" HHCS, and Flange Nut, figure 9.

- B. For three phase lifts: Remove Limit Switch cover, Fig. 9a. Insert Actuator end of Switch Bar into slot located inside Limit Switch, Fig. 9a. A small amount of silicone sealant on the lower part of the actuator will help hold it in place. Insert 1/4"-20NC x 2" HHCS through pivot hole in end of Switch Bar. Then secure HHCS and Switch Bar to overhead as shown, using 3/4" spacer and 1/4"-20NC Locknut. Tighten Hex bolt leaving 1/16" gap between the spacer and the overhead assembly, Fig. 9. Replace limit switch cover.

- C. Attach the overhead beam to the uprights.
- * Raise the overhead beam and secure it to the cylinder mount or upright using two 1/2 x 1-3/4 bolts, washers and nuts on each end, Figure 9.

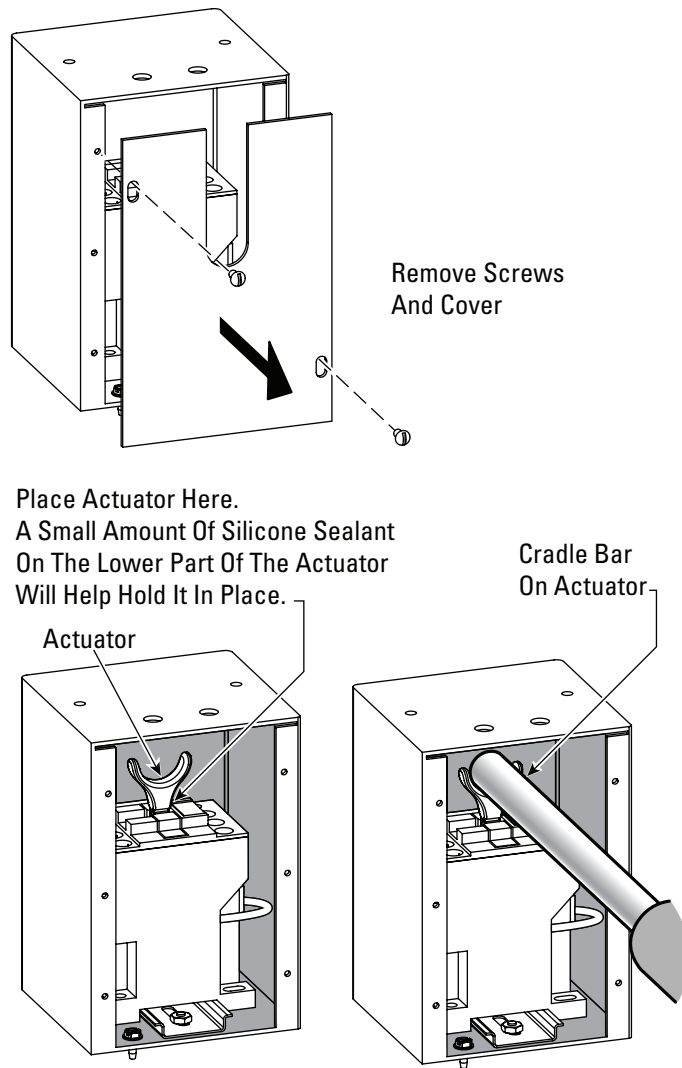

Figure 9a

9. Anchoring offside leg

- A. Using a level check the alignment and plumbness of the entire structure. Plumb the offside leg both side to side and front to back.
- B. The base of the leg may vary from the preliminary layout, as it is more important that the leg be perpendicular to the floor and parallel to the other leg.
- C. Install the anchor bolts and shim the base as described in the earlier "Leg positioning and anchoring" step.

10. Routing carriage equalization cables and offside hose, Figure 10.

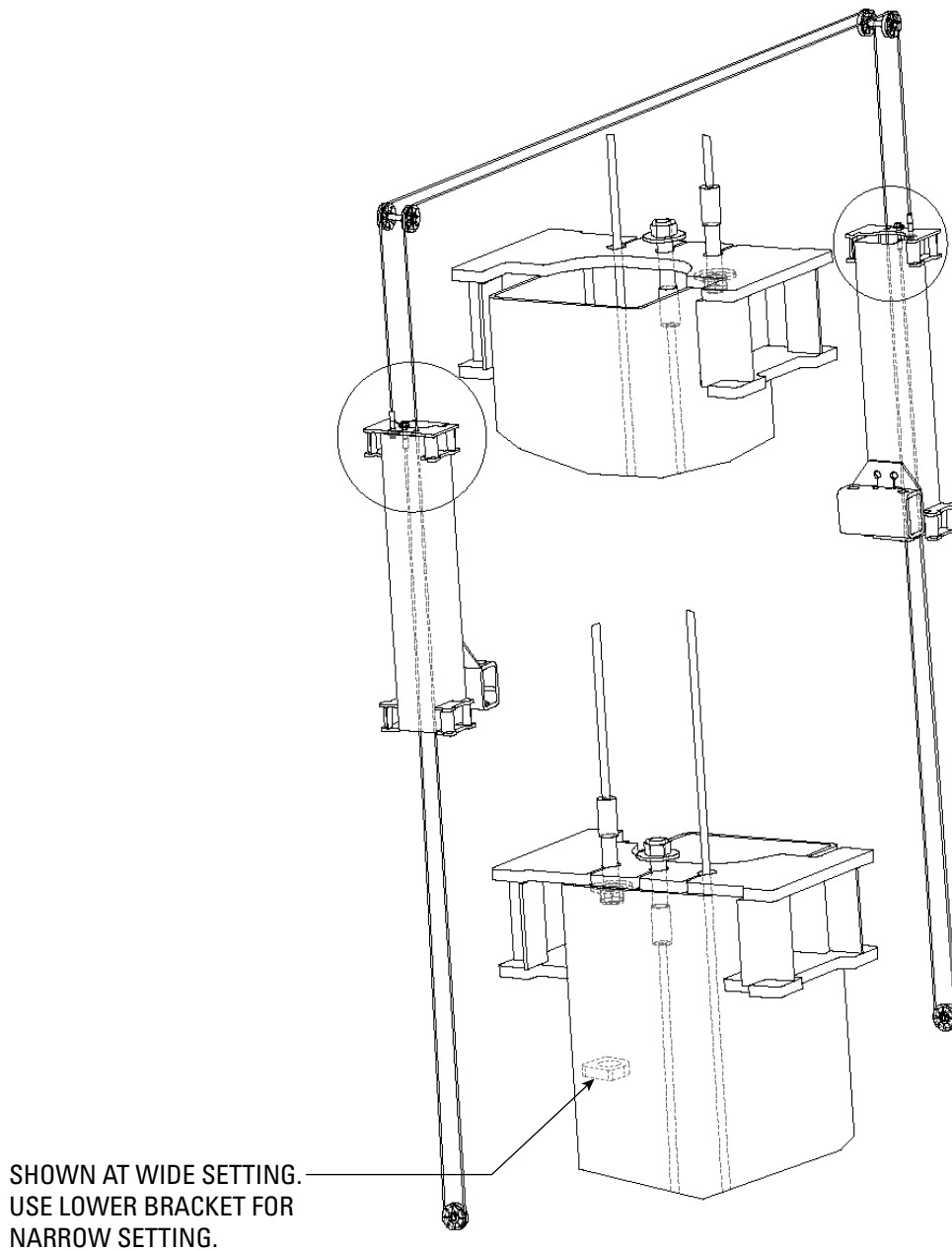

Figure 10

- A. The carriages should be resting on the same safety rack tooth. Measure the height above the baseplate for each carriage. The measurements should be within 3/8" of each other. Make a note of the two measurements.

- B. One end of each cable should already be attached to each carriage. Feed the other end of the cable up through the top of the leg as shown, Figure 10,

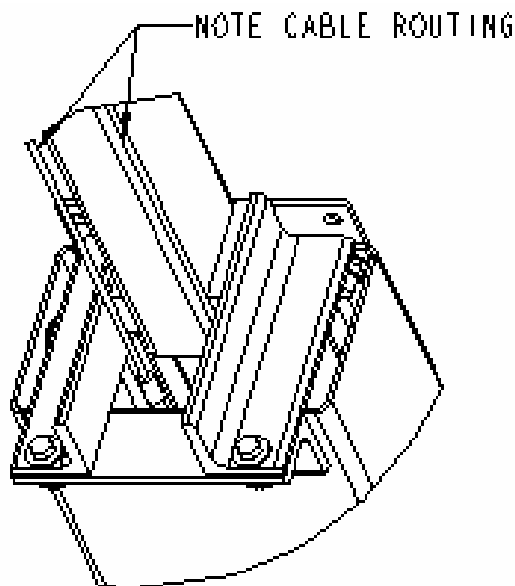

Figure 11

- * around the sheaves on the uprights,
 - » (while in the elevated position feed the offside hose through the hose guides welded to the top of the overhead tube and down through the offside upright tube.)
 - * feed cable through the clearance hole in the left hand corner of the carriage top,
 - * around the sheave at the bottom of the leg,
 - * through the hole in the center of the carriage top.
- C. Secure the cable end to the carriage top with a nylon insert nut and washer. Do not tighten the cable at this time.
- D. Repeat the process for the other cable, taking care not to cross them.
- E. Take out the slack, but do not tighten, in both cables by turning down the nuts on the top of each carriage top. Use vise grips to hold the cable end, but be very careful not to damage the threads.
- F. The carriages must remain at the same lock position while the cables are being tightened. Overtightening of one cable could raise the carriage in the opposite leg and cause the carriage safety latches to be out of sync.
- G. Alternately tighten the cable nuts at both carriages until the cables are tightened. Correct tension in the cables is indicated by being able to pull the cables together with approximately 15 pounds of effort at their midpoint in the leg.
- H. Measure and compare the carriage heights to the earlier measurement, or check that the safety locks will not disengage to verify that neither carriage has been raised. If a carriage has been raised more than 1/8", loosen the cables and repeat the procedure.

- I. If the cables are installed correctly, both carriages will raise together. If equipment capable of lifting the carriages is readily available, lift one of them just enough to disengage the locks and carefully lower to the ground. This will simplify the cylinder bleeding procedure.

11. Locking Latch Cable

- A) Install latch cable sheave and retaining rings in upper slot of power unit column as shown, Fig. 13.
 - B) Slip loop end of cable over end of shoulder screw on right side latch control plate, Fig. 13.
 - C) Feed the other end of the cable through the latch cable sheave slot making sure that the cable is running under the bottom side of the latch cable sheave and inside the right column, Fig. 13.
 - D) Attach latch cable conduit guide brackets to overhead as shown, Fig. 12 & Fig. 12a. Always use the holes on the approach side of the lift. HHCS should be in hole nearest the center of the overhead, Fig. 12a.
 - E) Route cable up inside column and through the latch cable guide, Fig. 12a & Fig. 14.
IMPORTANT Using wire ties provided, tie off cable guide to column extension as shown, Fig. 12a. Guide must be attached in hole closest to the outside edge of the column on the NON-APPROACH side.
 - F) Continue routing cable to the left column latch cable guide, Fig. 12 & Fig. 14, routing the cable through the left column latch cable guide, Fig. 12.
IMPORTANT Using wire ties provided, tie off cable guide to column extension as shown, Fig. 12a. Guide must be attached in hole closest to the outside edge of the column on the NON-APPROACH side.
 - G) Bring the cable down inside the left column and feed the end of the cable through the lower latch cable sheave slot so that the cable is now back outside the column, Fig. 15.
 - H) Install latch cable sheave and retaining rings in lower slot of non-power unit column as shown, Fig. 15.
 - I) Route cable under the bottom side of the latch cable sheave, Fig. 15.
 - J) At this point you **MUST** install the latch handle, jam nut, and right column latch cover Fig. 13 & Fig. 16. Install latch handle ball, Fig. 16.
 - K) Insert cable in cable clamp along one side, loop around shoulder screw and back down, inserting cable along other side of cable clamp, Fig. 15. Place top back on clamp, barely tightening.
 - L) Next, pull the control plate down, Fig. 14 & Fig. 15, to eliminate any clearance between the control plate slot and the latch dog pin, Fig. 14.
 - M) Using Pliers, pull cable tight and secure the clamp close to the shoulder screw. Tighten clamp.
12. **Mounting the power unit.** Attach four 5/16" x 1-1/4" bolts to the highest two and lowest two holes in the mounting bracket with 5/16" plain nuts. Attach the power unit, to these bolts and secure with 5/16" nylon insert nuts.

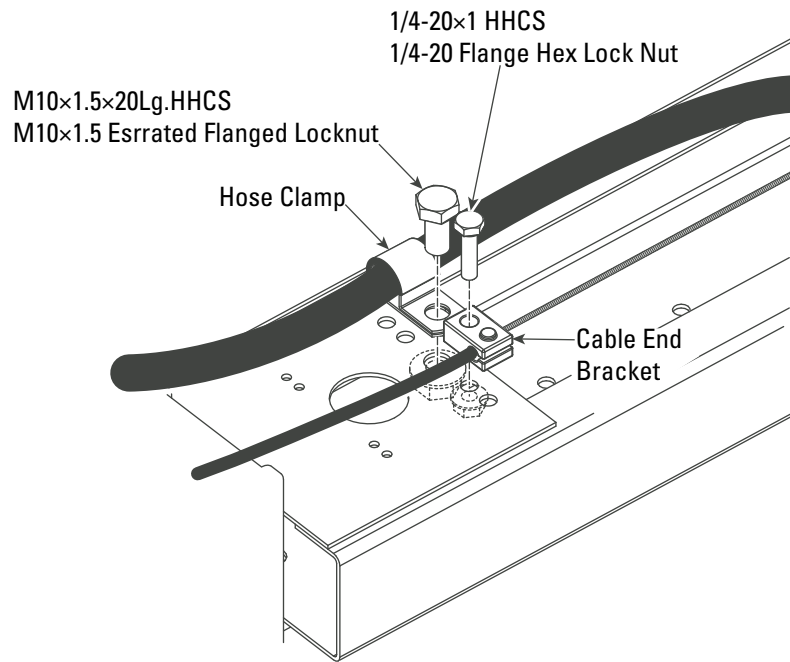

Figure 12

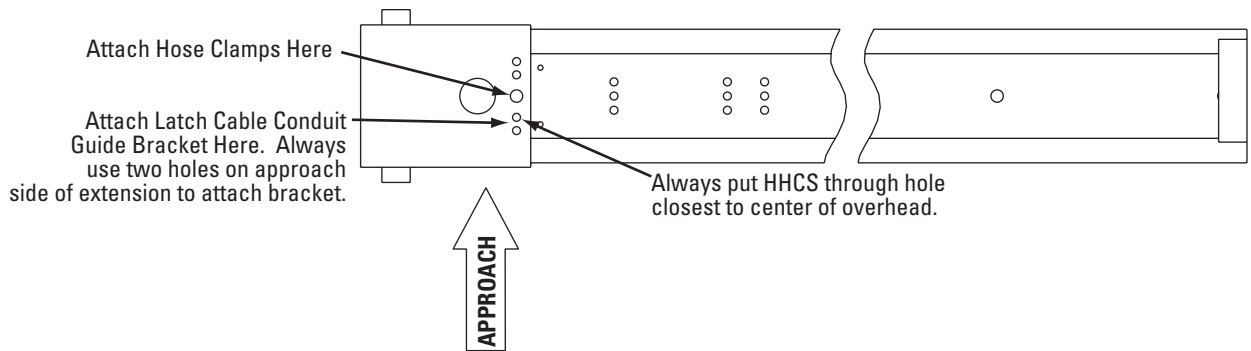

Figure 12a

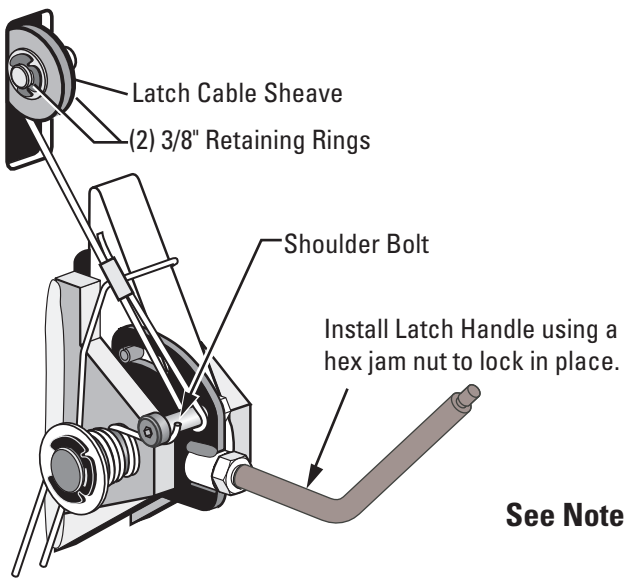

Figure 13

See Note

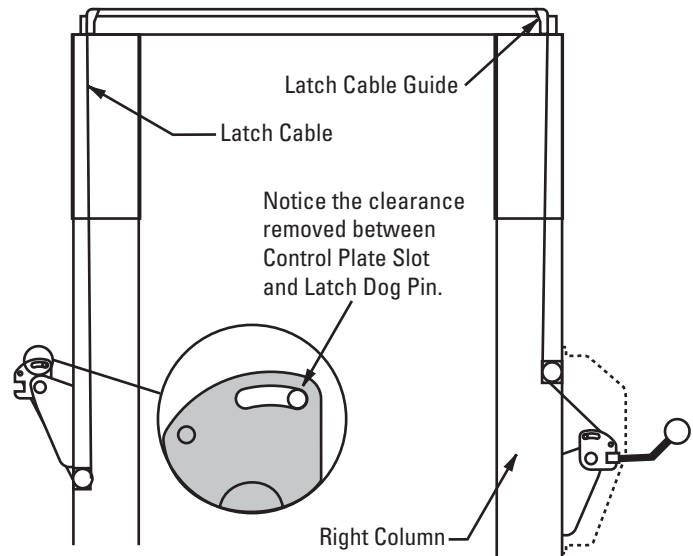

Figure 14

See Note

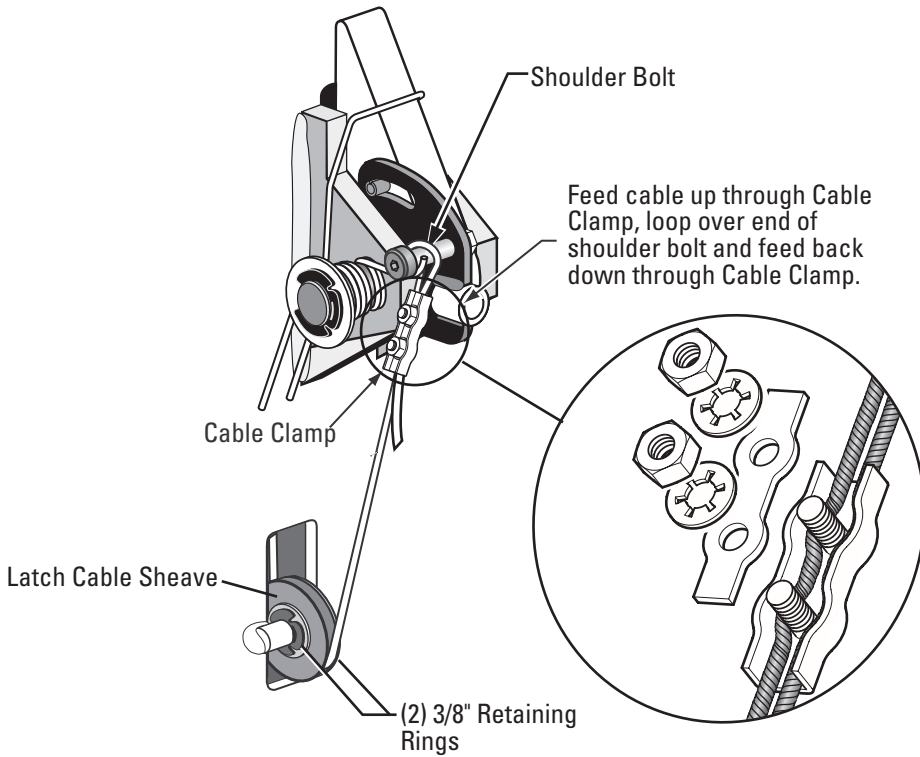

Figure 15

See Note

NOTE Handle can be installed in a downward orientation to reduce the distance to reach the handle, Figures 13, 14, and 16.

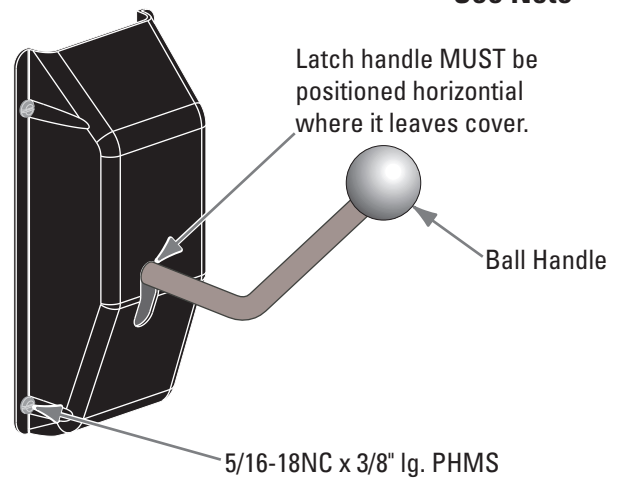

Figure 16

13. **Hydraulic system, Figure 17.**

- A. The right side of the power unit from the controls has one open port. Attach the o-ring elbow to this port with the open end up.
- B. Attach the hose hanging from the rubber grommet at the top of the leg to the elbow on the power unit.
- C. Attach the hose hanging from the offside upright to the elbow at the bottom of the offside cylinder hand-tight.
- D. To prevent the carriages from rubbing the hoses, pull the hoses upward taking out any slack between the cylinder fitting port and the cylinder mount. Secure the hoses to the mainside cylinder with wire tie around the tee and the cylinder, the tee should be positioned to aim directly out through the grommet, Figure 17. Secure the hose to the offside cylinder at approximately the same height with a wire tie.

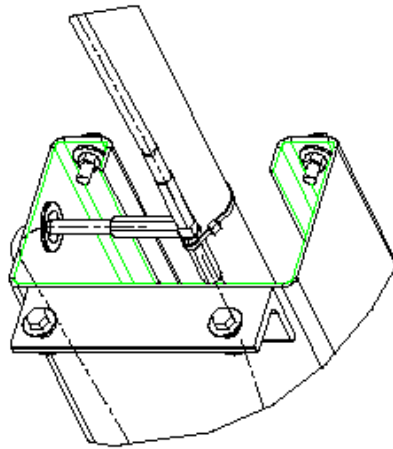

Figure 17

- E. Any excess hose should be taken up in the uprights, or at the corners between the uprights and the overhead.
- F. Add fluid. Remove the fill level screw near the top of the power unit tank. Remove the fill-cap from the tank and fill with Dexron III ATF or hydraulic oil that meets ISO-32, until fluid reaches the bottom of the screw hole. Replace the fill screw and tank breather.

14. **Electrical.**

A. Single Phase

- * Have a certified electrician establish 208-230V, single phase, 60 Hz, 20 amp, Figure 18, power supply to motor and overhead switch .
- * Use separate circuits for each lift.
- * Single phase motor cannot be run on 50 Hz line without modifications in the motor.

Three Phase

- * Three phase 208-240V, use 20 amp fuse. For three phase 460V -480V and above, use 10 amp fuse, Figure 18a.

Figure 18

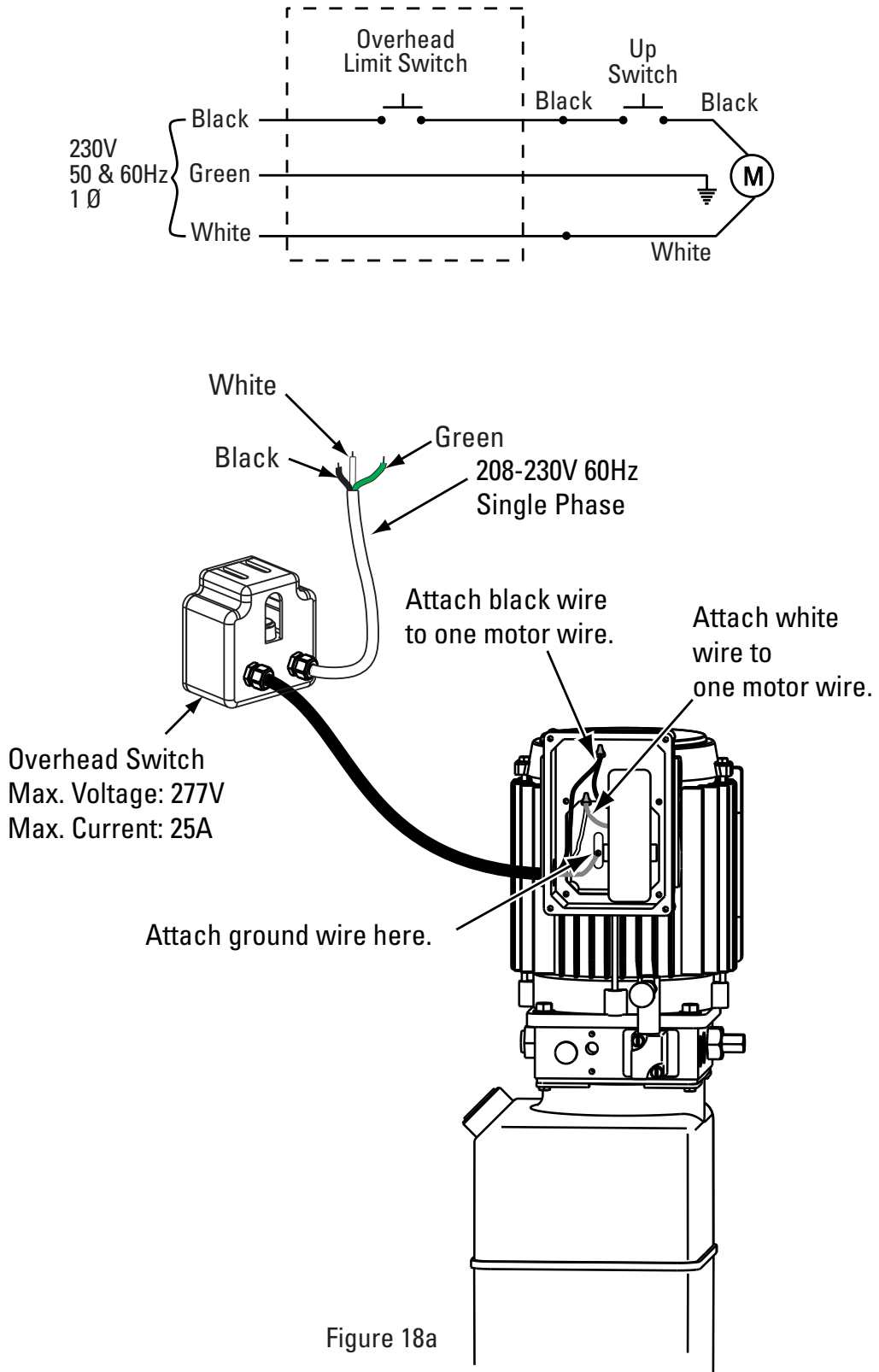
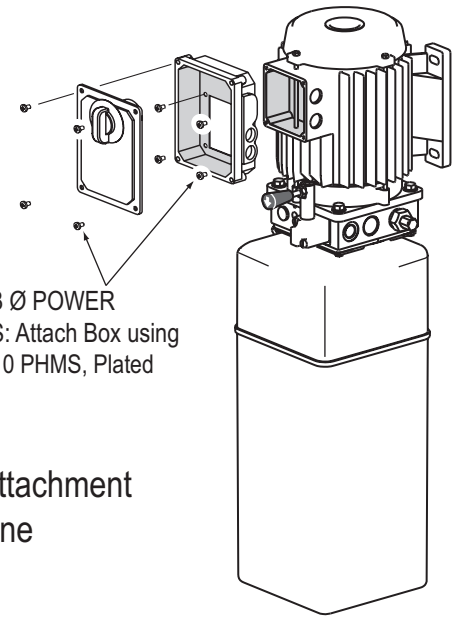
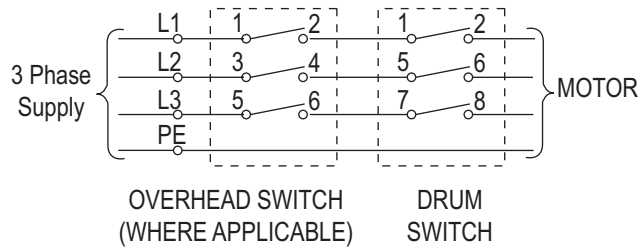

Figure 18a

NOTE: Two Different Drum Switches were used please select one of the two options below.

NOTES:

1. Unit not suitable for use in unusual conditions. Contact Rotary for moisture and dust environment duty unit.
2. Control Box must be field mounted to power unit.
3. Motor rotation is counter clockwise from top of motor.



Capacitor Box Attachment Option One

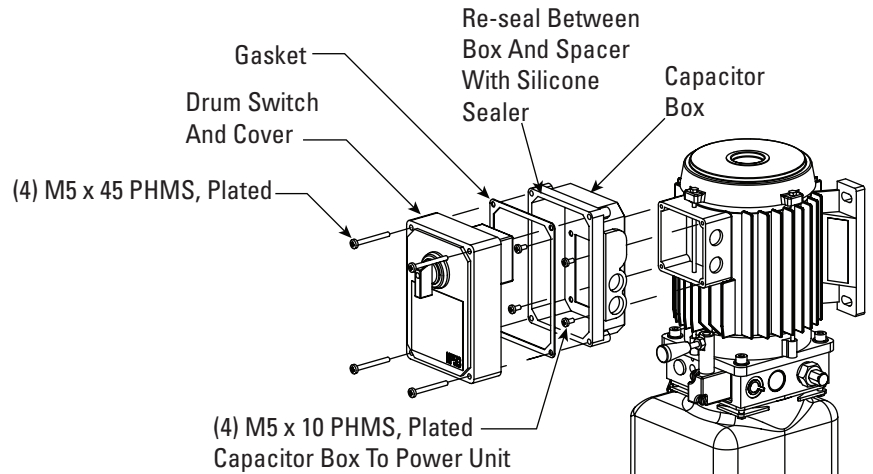

Capacitor Box Attachment Option Two

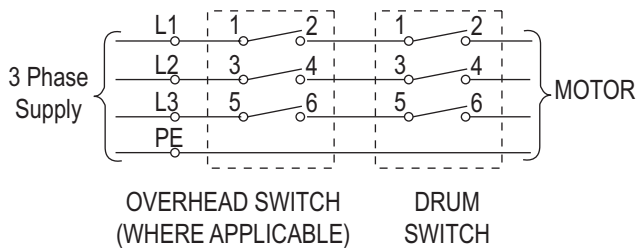

Single Phase Power Unit

MOTOR OPERATING DATA TABLE - SINGLE PHASE	
LINE VOLTAGE	RUNNING MOTOR VOLTAGE RANGE
208-230V 50Hz.	197-253V
208-230V 60Hz.	197-253V

Three Phase Power Unit

MOTOR OPERATING DATA TABLE - SINGLE PHASE	
LINE VOLTAGE	RUNNING MOTOR VOLTAGE RANGE
208-240V 50/60Hz.	197-253V
400V 50Hz.	360-440V
440-480V 50/60Hz.	396V-528V
575V 60Hz.	518V-632V

IMPORTANT: Use separate circuit for each power unit. Protect each circuit with time delay fuse or circuit breaker. For single phase 208-230V, use 20 amp fuse. Three phase 208-240V, use 20 amp fuse. For three phase 460V and above, use 10 amp fuse. All wiring must comply with NEC and all local electrical codes.

Three Phase Power Unit

MOTOR OPERATING DATA TABLE - THREE PHASE	
LINE VOLTAGE	RUNNING MOTOR VOLTAGE RANGE
208-240V 50/60Hz.	197-253V
400V 50Hz.	360-440V
440-480V 50/60Hz.	396V-528V
575V 60Hz.	518V-632V

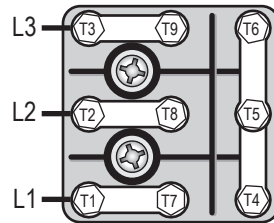

208-240V
50/60Hz. 3Ø

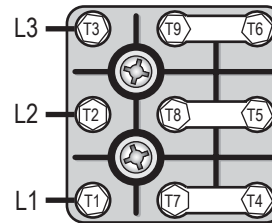

440-480V 50/60 Hz. 3Ø
380-400V 50 Hz. 3Ø

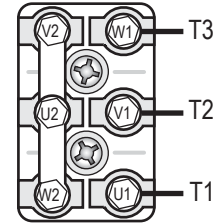

575V 60 Hz. 3Ø

15. **Bleeding the hydraulic system, Figure 17.**

- A. Loosen the connections **between the hoses and fittings** attached to the cylinders. **Do not** loosen the connections **between the fittings and the cylinders themselves.**
- B. Run the power unit until fluid appears at the mainside cylinder port. Tighten that hose connection.
- C. Run the power unit until fluid appears at the offside cylinder port and there is no more air. Tighten that hose connection.
- D. Lower the lift to the ground. If the lift is on the safety latches, raise the lift enough to disengage the latches and then lower.
- E. If the carriages were on the ground when the bleeding process was begun, no further bleeding is required. If not, repeat the previous steps for bleeding the hydraulic system.
- F. **Add fluid to the system as previously described.**

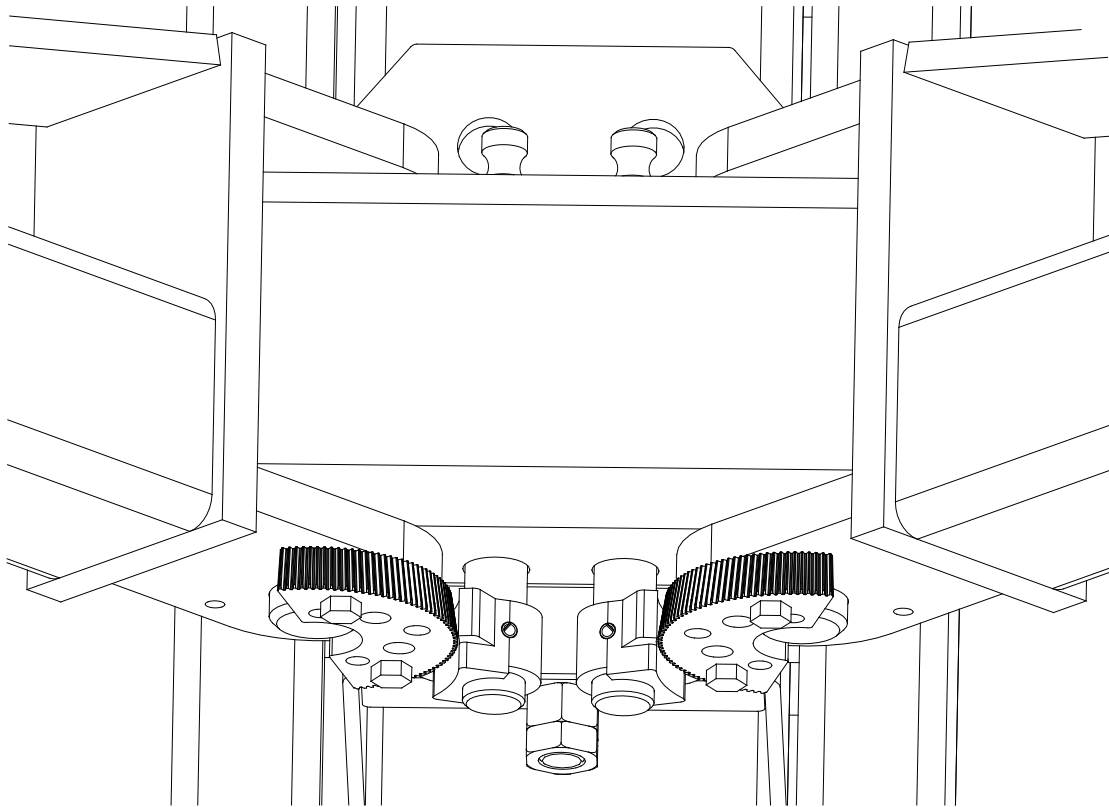

Figure 19

16. **Assembling the arms and arm restraints**

- A. Before installing the arms, install the restraint gears as follows.
- B. Position the gears with word TOP against the bottom of the arms in the orientation shown in Figure 20. Attach the gears to the arms with (2) 3/8-16NC X 1-1/2 long HHCS. Do not tighten at this time.
- C. Position the restraint pawls on the carriage to mate with the gears on the arms.

17. **Arm Stop**

- A. Install arm stop on Power Unit Column rear (long) arm. Long arm must be installed on power unit side of column.
- B. Raise arm pin out of carriage until you have enough room to slide the arm stop into place.

NOTE the orientation of the arm stop.

* Place the arm pin down through the arm stop and into lower part of clevis.

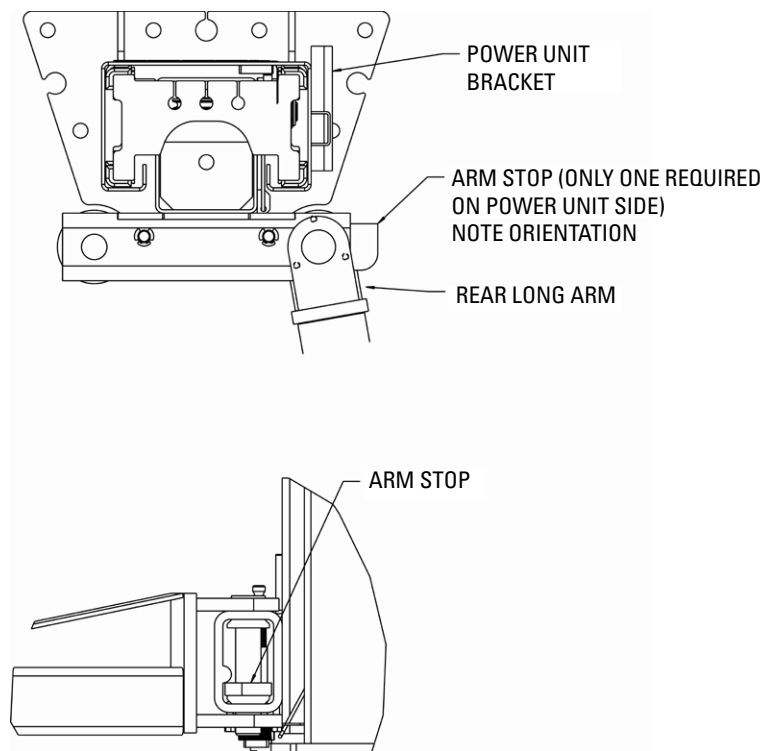

Figure 20

- * Install the swing arms and swing arm pins. If the arms are of different lengths, the longer arms go to the rear or drive in side of the lift, and the short arms go to the front, Figure 20.

 - * Don't force the gears, it may be necessary to pull up on the restraint actuator pin in order to install the swing arm pin.
 - * Tighten the gear bolts to 30-34 ft-lbs.

 - * Install the swing arms and swing arm pins. If the arms are of different lengths, the longer arms go to the rear or drive in side of the lift and the short arms go to the front, Figure 20.

 - * Don't force the gears. It may be necessary to pull up on the restraint actuator pin in order to install the swing arm pin.

 - * Tighten the gear bolts to 30-34 ft-lbs.
18. Lubricate the four inside corners of both legs with heavy duty bearing grease.

19. **Final Adjustments**

- A. If any problems are encountered, do not proceed with subsequent steps. Instead, resolve the problem before proceeding by referencing the Troubleshooting portion of the Owner's Manual section of this manual.

- B. Raise the lift to full height. Lower the lift onto the safety latches. Raise the carriages, release the locks, and lower the lift to the ground.

- C. Raise the lift empty to the top of its travel and lower it the floor three (3) times to remove the remaining air from the hydraulic system.

- D. The latches should click together as the lift is being raised.

- E. When the carriages are lowered onto the locks, both locks should engage completely.

- F. The first time a vehicle is placed on the lift, raise it no higher than three feet. Lower the vehicle onto the safety latches. Raise the lift a few inches and release the lock then lower the vehicle to the floor.

- G. Raise the vehicle to full height and lower the carriages onto the safety latches. Lower the vehicle to the floor.

- H. After cycling the lift ten times with a vehicle on it, recheck the tightness of the anchors to at least 90 ft-lbs.

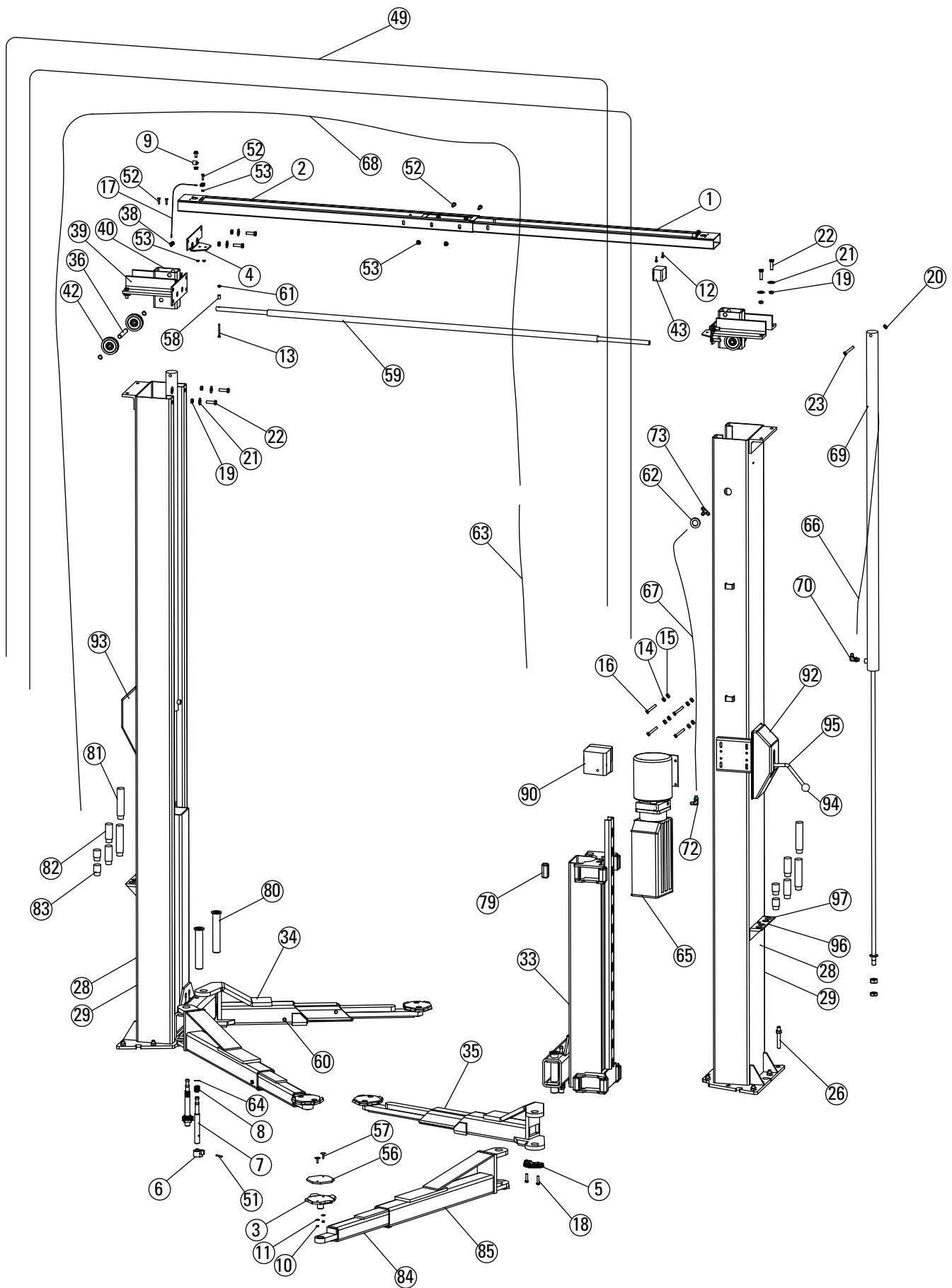

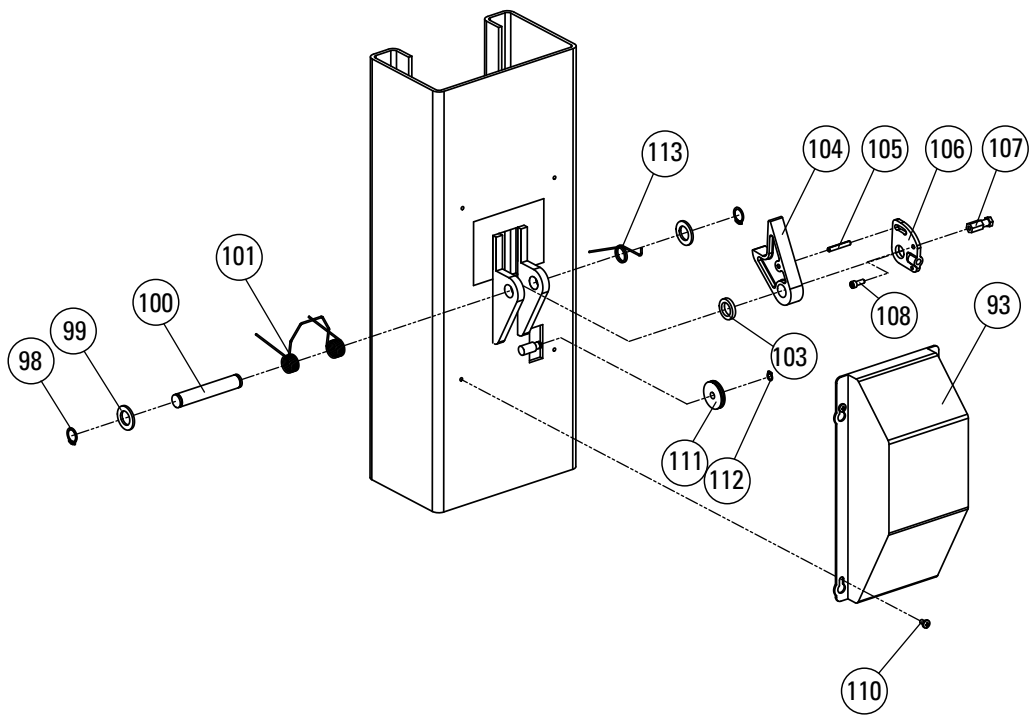
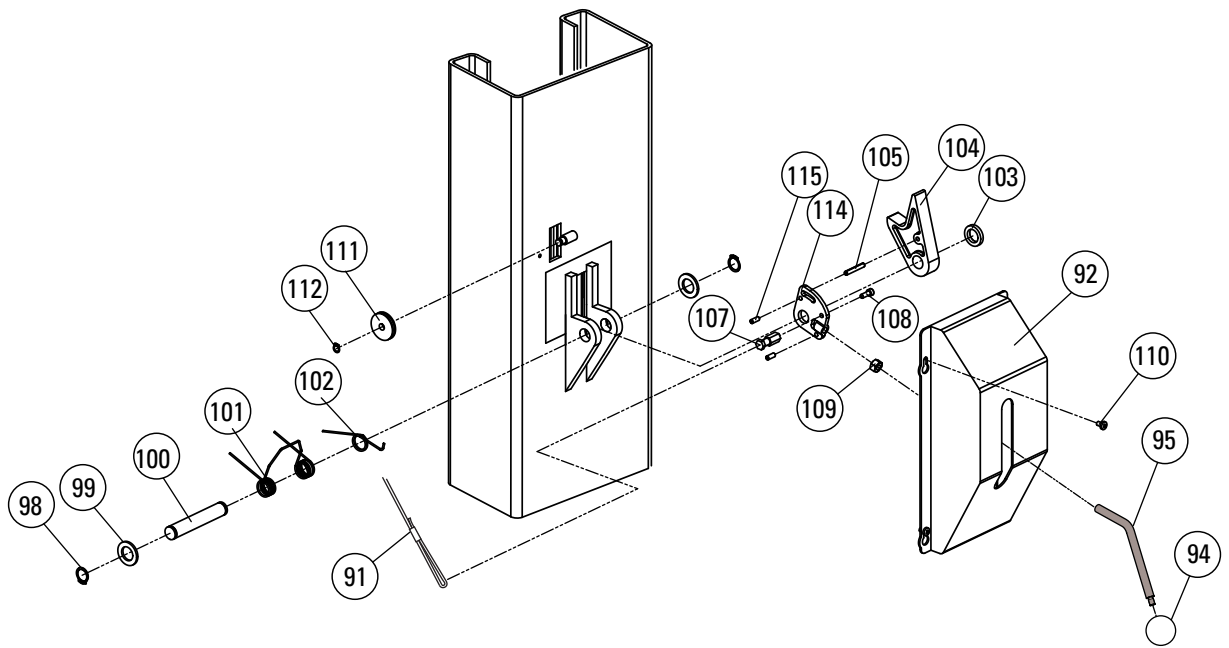

1	Mainside Overhead Weld	NDP10-3000A
2	Offside Overhead Weld	NDP10-3000B
3	Stackable Pad Weldment	106605
4	Overhead Bracket	NDP10-3004
5	Arm Restraint Gear	N2122
6	Arm Restraint Pawl	N2121
7	Arm Restraint Actuator Pin	143536
8	Arm Restraint Spring	143537
9	Hose Clamp	G3T-8005
10	1/4-20Nylon Insert Hex Nut	911401
11	1/4 Washer	911405
12	1/4-20 HHCS ×1/2 Lg	911421
13	1/4-20 HHCS ×2 Lg	911481
14	5/16-18 Hex Nut	911701
15	5/16-18 Nylon Insert Lock Nut	911703
16	5/16-18×1-1/4HHCS Grade 5	911751
17	Cable Sheath	N618
	EH Cable Sheath	NDP10-3005
18	3/8-16NC HHCS	912061
19	1/2-13 Hex Nut	912601
20	1/2-13 Nylon Insert Lock Nut	912603
21	1/2 Washer	912605
22	1/2-13 ×1-3/4 HHCS	912671
23	1/2-13 ×5 HHCS	912791
24	3/4-16 Hex Nut	913602
25	3/4-16 Hex Jam Nut	913611
26	3/4×5-1/2 Anchor Bolt	913828
27	NA	NA
28	Offside Leg Assembly	1070128
29	Offside Leg Weldment	NDP10-1100a
30	Mainside Leg Assembly	1070127
31	Mainside Leg Weldment	NDP10-1000a
32	NA	NA
33	Carriage Weld	NDP10-2000
34	Left Arm Assembly (Asymmetrical)	1070669
35	Right Arm Assembly (Asymmetrical)	1070670
36	Sheave Pin	0970802
37	Cylinder Bushing	0970804
38	Cable End Bracket	N619
39	Cylinder Mount/Upright Assembly	1070800
	Cylinder Mount/Upright Assembly Extended Rise/Extended Height	1072800
40	Cylinder Mount/Upright Weldment	1070801
41	Small Parts Bag	1070907
42	Cable Sheave	1070900
43	Single Phase Overhead Switch	N413

	Three Phase Overhead Switch	N432
44	NA	NA
45	NA	NA
46	NA	NA
47	NA	NA
48	NA	NA
49	Cable and Lock Nut	
	5/8-11 Nylon Insert Locknut	913303 or 40743
	dia.16mm washer	913206 or 40970
	dia.18mm washer	
	Cable	1070911
	Cable Extended Height	1072901
50	NA	NA
51	1/4 Roll Pin ×1-1/2Lg	991060
52	M10×1.5×20Lg.HHCS	41536
53	M10×1.5 Esrrated Flanged Locknut	41655
54	24" Wire Tie	991082
55	Shim	991127
56	Swivel Pad Rubber Insert	991234
57	1/4-20×1-1/4 Elev.Bolt	991243
58	Switch Bar Spacer	991480
59	Overhead Switch Bar, Single Phase	991481
	Overhead Switch Bar, Three Phase	N434
60	3/8NC×1/2Lg.Self-tapping screw	991487
61	1/4-20 Flange Hex Lock Nut	991490
62	Rubber Grommet	991491
63	Hose Extension (Extended Rise Only)	992167
64	3/4 Klip Ring	991504
65	Single Phase Power Unit	P3397
	Single Phase Power Unit 50Hz	P3398
	Three Phase Power Unit	P3414
66	Mainside Hose	992156
67	Power Unit Hose	992101
68	Offside Hose	NDP10-9801-1
69	Cylinder	992317
	Cylinder Extended Rise	992327
70	3/8 JIC to 3/8 NPT Elbow	992402
71	NA	NA
72	9/16 O-Ring to 3/8 JIC Elbow	992410

73	3/8 JIC Tee	992502
75	NA	NA
76	NA	NA
77	NA	NA
78	NA	NA
79	Rub Block	995120
80	Arm Pin	995430
81	6" Pad Extension	995550
82	3" Pad Extension	995560
83	1-1/2" Pad Extension	996220
84	Symmetric Arm Assembly	1080601
85	Rear Arm Assembly (Asymmetric)	1070639
86	NA	NA
87	NA	NA
88	NA	NA
89	NA	NA
90	Control Box (3 Phase)	FA7366
91	Latch Release Cable	FJ7600
92	Mainside Latch Cover	PV-1001
93	Offside Latch Cover	PV-1002
94	Handle Ball	B84-35
95	Latch Handle	PV-1007
96	Adapter Bracket	NDP10-1010
97	Adapter Bracket Kit	NDP10-D4
98	dia. 20mm Circlip	B60-20
99	dia. 20mm Washer	B41-20
100	Latch Pin	PV-1006
101	Spring	PV-1040
102	Spring	PV-1009
103	Spacer	PV-1015
104	Latch Block	PV-1005
105	M6×40mm Spring Pin	B51-6×40
106	Control Plate	PV-1003
107	Hex Bolt	PV-1008
108	M6×16mm Bolt	B20-6×16
109	M10 Nut	B30-10
110	M6×10mm Bolt	B231-6×10
111	Sheave	PV-1013
112	dia. 20mm Circlip	B60-10
113	Spring	PV-1009DC
114	Control Plate	PV-1004
115	M6×16mm Bolt	B21-6×16
116	1/4-20×1 HHCS	40108

NOTES

