

TWO POST LIFT INSTALLATION AND OWNERS MANUAL

DP10 Series

Capacity 10,000 lbs.

April 2004
994322
Rev. J

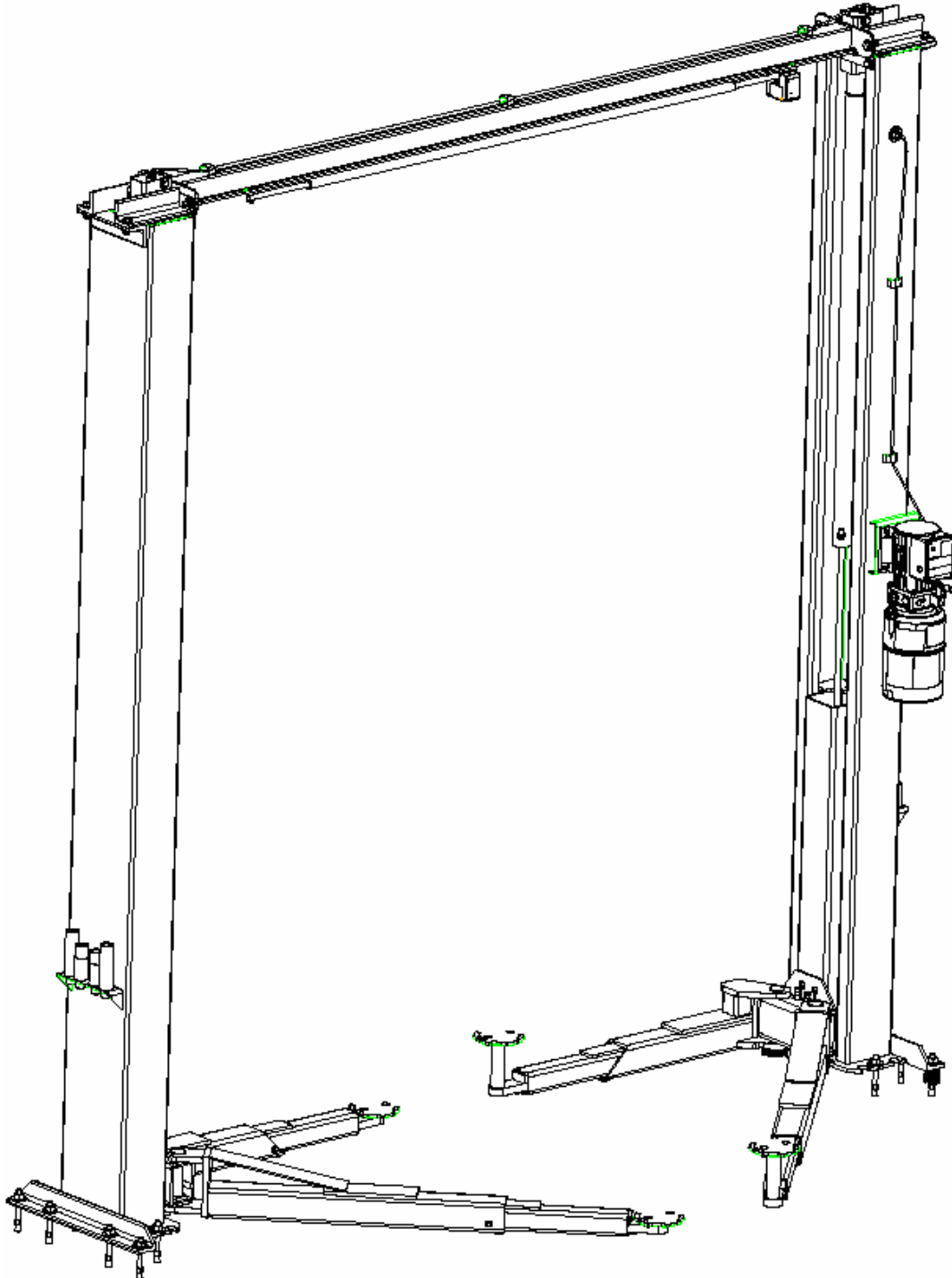

TABLE OF CONTENTS

Important Information	2
Section 1 Owner's Manual	
Safety Instructions	3
Monthly Maintenance	5
Troubleshooting	5
Section 2 Installation Instructions	
Tools Required for Installation	8
Procedure	8
Section 3 Parts Breakdown	
Detailed Views & Parts List	28

Important Information:

1. **Read this manual thoroughly** before installing, operating, or maintaining this lift.
2. This lift is designed for indoor use only, and should not be installed in a pit or depression.
3. The floor on which the lift is to be installed must be 4-1/4" inch minimum thickness concrete, with a minimum compressive strength of 3000 psi, and reinforced with steel bar.
4. The lifts have specific electrical requirements as described in the Installation Instructions section of this manual.
5. This lift has a minimum ceiling height requirement as described in the Installation Instructions section of this manual.
6. **Failure by the owner to provide the recommended shelter, mounting surface, electrical supply, and ceiling height could result in unsatisfactory lift performance, property damage, or personal injury.**











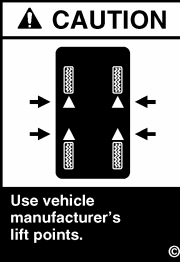

Section 1

Owner's Manual

Safety Instructions:

1. **Do not raise a vehicle on the lift until the installation is completed as described in this manual.**
2. **Anyone who will be in the vicinity of the lift** when it is in use should read and refer to the following publications supplied with this lift:
 - “INSTALLATION AND OWNERS MANUAL”, I MAN 994322
 - “LIFTING IT RIGHT”, ALI SM93-1.
 - “AUTOMOTIVE LIFT SAFETY TIPS”, ALI-ST90.
 - “VEHICLE LIFTING POINTS FOR FRAME ENGAGING LIFTS”, ALI/LP-GUIDE.
 - “SAFETY REQUIREMENTS FOR OPERATION, INSPECTION, AND MAINTENANCE”, ANSI/ALI ALOIM-1994.
3. **Technicians** should be trained to use and care for the lift by familiarizing themselves with the publications listed above. The lift should never be operated by an untrained person.
4. **Always position the arms and adapters properly out of the way** before pulling the vehicle into, or out of the bay. Failure to do so could damage the vehicle and/or the lift.
5. **Do not overload the lift.** The capacity of the lift is shown on cover of this document and on the lift's serial number tag.
6. **Positioning the vehicle** is very important. Only trained technicians should position the vehicle on the lift. Never allow anyone to stand in the path of the vehicle as it is being positioned.
7. **Position the arms to the vehicle manufacturer's recommended pickup points.** Raise the lift until contact is made with the vehicle. Make sure that the arms have properly engaged the vehicle before raising the lift to a working height.
8. **Keep everyone clear of the lift when the lift is moving, the locking mechanism is disengaged, or the vehicle is in danger of falling.**
9. **Unauthorized personnel** should never be in the shop area when the lift is in use.
10. **Inspect the lift daily.** The lift should never be operated if it has damaged components, or is malfunctioning. Only qualified technicians should service the lift. Replace damaged components with manufacturer's parts, or equivalent.
11. **Keep the area around the lift clear** of obstacles.
12. **Never** override the self-returning lift controls.
13. **Use safety stands** when removing or installing heavy vehicle components.
14. **Avoid excessive rocking** of the vehicle when it is on the lift.
15. **To reduce the risk of personal injury**, keep hair, loose clothing, fingers, and all body parts away from moving parts.

16. **To reduce the risk of electric shock**, do not use the lift when wet, do not expose the lift to rain.
17. **To reduce the risk of fire**, do not operate equipment in the vicinity of open containers of flammable liquids (gasoline).
18. **Use the lift only as described in this manual**, use only manufacturer's recommended attachments.
19. Unusual vehicles, such as limousines, RV's, and long wheelbase vehicles, may not be suitable for lifting on this equipment. If necessary, consult with the manufacturer or the manufacturer's representative.
20. The troubleshooting and maintenance procedures described in this manual can be done by the lift's owner/employer. Any other procedure should only be performed by trained lift service personnel. These restricted procedures include, but are not limited to, the following: cylinder replacement, carriage and safety latch replacement, leg replacement, overhead structure replacement.
21. **Anyone who will be in the vicinity of the lift** when it is in use should familiarize themselves with following Caution, Warning, and Safety related decals supplied with this lift, and replace them if they are illegible or missing:

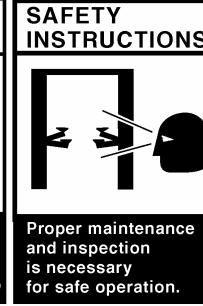
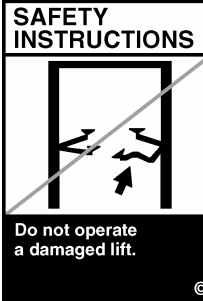
 <p>CAUTION</p> <p>Lift to be used by trained operator only.</p>	 <p>CAUTION</p> <p>Authorized personnel only in lift area.</p>	 <p>WARNING</p> <p>Clear area if vehicle is in danger of falling.</p>	 <p>WARNING</p> <p>Position vehicle with center of gravity midway between adapters.</p>
 <p>CAUTION</p> <p>Use vehicle manufacturer's lift points.</p>	 <p>CAUTION</p> <p>Always use safety stands when removing or installing heavy components.</p>	 <p>WARNING</p> <p>Remain clear of lift when raising or lowering vehicle.</p>	 <p>WARNING</p> <p>Avoid excessive rocking of vehicle while on lift.</p>
 <p>CAUTION</p> <p>Use height extenders when necessary to ensure good contact.</p>	 <p>CAUTION</p> <p>Auxiliary adapters may reduce load capacity.</p>	 <p>WARNING</p> <p>Do not override self-closing lift controls.</p>	 <p>WARNING</p> <p>Keep feet clear of lift while lowering.</p>
<p>The messages and pictographs shown are generic in nature and are meant to generally represent hazards common to all automotive lifts regardless of specific style.</p> <p>Funding for the development and validation of these labels was provided by the Automotive Lift Institute, PO Box 33116 Indialantic, FL. 32903-3116.</p> <p>They are protected by copyright. Set of labels may be obtained from ALI or its member companies.</p> <p>© 1992 by ALI, Inc. ALI/WL101d</p>		<p>The messages and pictographs shown are generic in nature and are meant to generally represent hazards common to all automotive lifts regardless of specific style.</p> <p>Funding for the development and validation of these labels was provided by the Automotive Lift Institute, PO Box 33116 Indialantic, FL. 32903-3116.</p> <p>They are protected by copyright. Set of labels may be obtained from ALI or its member companies.</p> <p>© 1992 by ALI, Inc. ALI/WL101w</p>	
		<p>SAFETY INSTRUCTIONS</p>  <p>Read operating and safety manuals before using lift.</p>	<p>SAFETY INSTRUCTIONS</p>  <p>Proper maintenance and inspection is necessary for safe operation.</p>
		<p>SAFETY INSTRUCTIONS</p>  <p>Do not operate a damaged lift.</p>	<p>The messages and pictographs shown are generic in nature and are meant to generally represent hazards common to all automotive lifts regardless of specific style.</p> <p>Funding for the development and validation of these labels was provided by the Automotive Lift Institute, PO Box 33116 Indialantic, FL. 32903-3116.</p> <p>They are protected by copyright. Set of labels may be obtained from ALI or its member companies.</p> <p>© 1992 by ALI, Inc. ALI/WL101s</p>

Monthly Maintenance:

1. Lubricate the four inside corners of the legs with heavy duty bearing grease.
2. With lift lowered check the hydraulic fluid level. If necessary add oil as described in the Installation Instruction section of this manual
3. Check carriage latch synching: Latches should click at the same time. If necessary adjust equalization cables as described in the Installation Instruction section of this manual.
4. Check tightness of all bolts.
5. Check anchor bolt tightness. If the anchor bolts are loose, they should be re-torqued to 90ft/lbs.
 - Check the nuts for tightness every week for the first month, and every month afterwards.
6. Replace worn or broken parts with lift manufacturer's parts, or their equivalent.

Troubleshooting:

7. The power unit does not run:
 - Check electrical supply breaker, or fuse.
 - Check for activation of the travel limit switch by a tall vehicle.
 - Check micro-switch and connections in motor control box.
 - Check voltage to the motor.
 - Check micro-switch and connections in the overhead switch box.
8. The power unit runs but does not raise the lift:
 - Check the oil level.
 - Check that the lowering valve is not stuck open.
 - Check the connections and components on the suction side of the pump.
9. The power unit raises the lift empty, but will not lift a vehicle.
 - Make sure the vehicle is not above the rated capacity of the lift.
 - Make sure the vehicle is positioned properly.
 - Clean the lowering valve by running the power unit for 30 seconds while holding the lowering valve open.
 - Check the motor voltage.
10. Lift drifts down.
 - Check for external leaks.
 - Clean the lowering valve by running the power unit for 30 seconds while holding the lowering valve open. Repeat this procedure three times.
 - Clean the check valve seat.
11. Slow Lifting and/or oil foaming up.
 - Check that oil used meets the specification in the Installation Instruction section of this manual.
 - Tighten all suction line fittings.
12. Anchors continually work loose
 - If holes were drilled too large relocate the lift per the Installation Instruction section of this manual.

- Floor is not sufficient to provide the necessary resistance, remove an area of concrete and repour as described in the Installation Instruction section of this manual.
13. Lift does not raise and lower smoothly.
- Reposition vehicle for a more even weight distribution.
 - Check the four inside corners of the two legs for roughness. Any rust or burrs must be removed with 120 grit emery cloth.
 - Lubricate the leg corners with heavy duty bearing grease.
 - Use a level to check the legs for vertical alignment both side to side and front to back. Shim the legs as necessary per the Installation Instruction section of this manual.
 - Check the oil level.
 - Make sure there is no air in the hydraulic lines, bleed system as described in the Installation Instruction section of this manual.
14. The lift will only lower approximately 1", then stops.
- Check that the safety latch pull rods are disengaged.
 - * If after disengagement of the pull rods, one of them moves back up as the lift is lowered, the pull rod is out of adjustment and is rubbing on the leg. Adjust the rod to clear the leg. Push down on the first bend of the rod just inside the leg. Bend the rod slightly to allow it to move freely between the leg and the carriage.

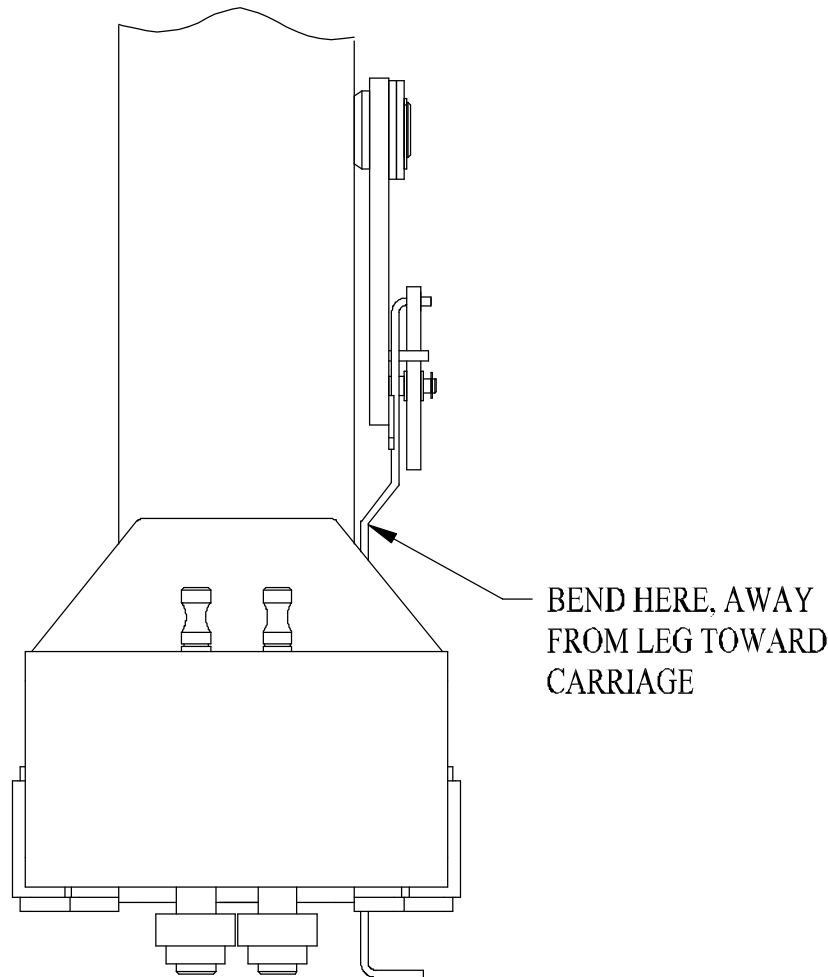

Figure 1

15. At full rise the latch will not disengage and the lift cannot be lowered.
- If the equalization cables are out of adjustment the carriages are out of sync, and when the lift is at full rise one of the safety latches may not have the clearance to disengage and allow the lift to lower.
 - * To lower the lift
 - ⇒ Raise the lift to full height.
 - ⇒ **Push In** both safety latch pull rods to **engage** latches.
 - ⇒ Use a hydraulic jack and a length of pipe to raise the carriage with the lock which is sticking enough to disengage the safety latch. Pull the latch rod on that carriage only.
 - ⇒ Remove the jack and pipe.
 - ⇒ Pull the latch rod on the other carriage to disengage the latch.
 - ⇒ Lower the lift and remove the vehicle.
 - ⇒ Readjust the cables as described in the Installation Instruction section of this manual.
16. Power Unit will not stop running
- Switch is damaged, **turn off power to the lift** and replace switch.

Section 2

Installation Instructions

Tools required for installation:

- Concrete hammer drill with 3/4" bit
- 11/16" open end wrench
- 3/4" open end wrench
- Torque wrench
- 15/16" deep socket or wrench
- 1-1/8" socket
- 13/16" open end wrench
- Level (18" minimum length)
- Vise grips
- Tape measure
- Funnel
- Hoist or Forklift (optional)
- Two 12' step ladders
- 1/4" drive ratchet with 5/16" socket

Procedure:

1. **Read this manual thoroughly** before installing, operating, or maintaining this lift.
2. **Site Evaluation and Lift Location:**
 - A. Always use an architect's plan when provided. Before unpacking the lift entirely, determine if the site is adequate for the lift model being installed see figures 2 and 3 for typical bay layout and ceiling height requirements.
 - B. Snap chalk lines to identify the lift's centerline.
 - C. Snap a chalk line parallel to the lift's centerline, spaced 9" toward the rear of the bay. This line represents the back edge of the leg bases.
 - D. Snap chalk lines parallel to the lift's centerline spaced 68-1/2 to the left and 68-1/2 to the right. These lines represent the APPROXIMATE outside edges of the leg bases,
 - * **DO NOT USE THESE LINES TO POSITION THE LEGS, FOLLOW THE INSTRUCTIONS IN THIS MANUAL.**

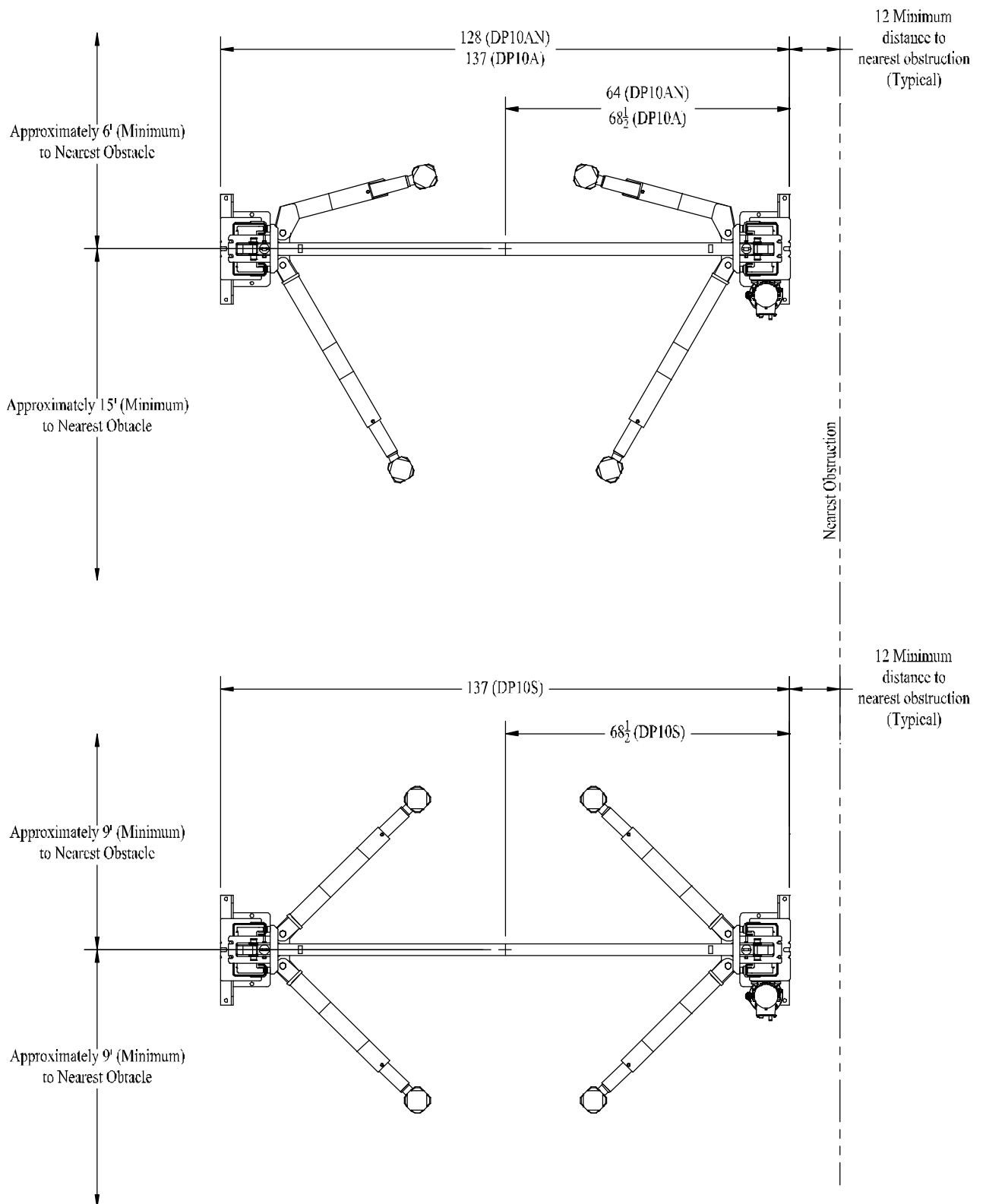

Figure 2

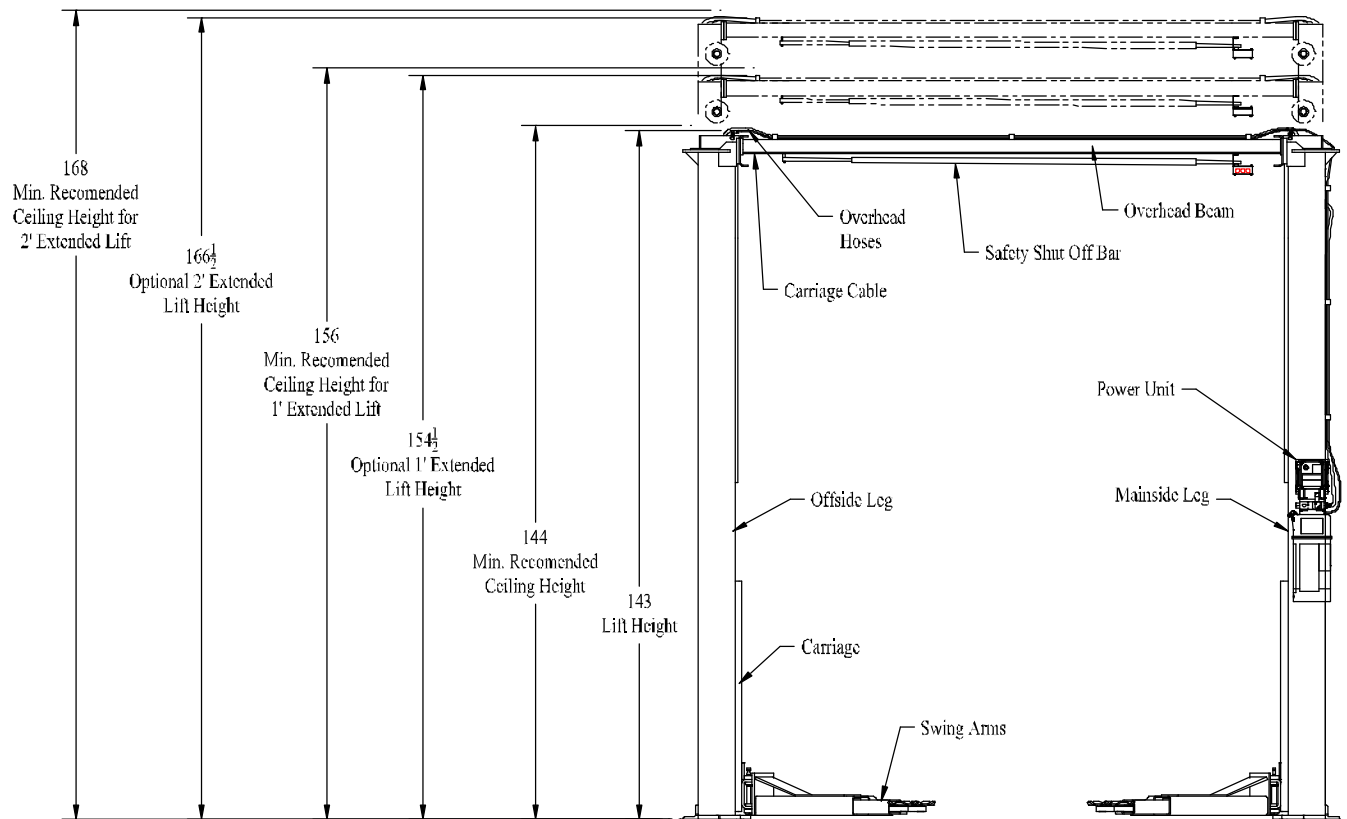

Figure 3

3. **Unpack the lift.** Remove the swing arms, bolt box, power unit box, and overhead beam.
 - A. **Save all packing hardware, as these components are necessary to complete the installation.**
 - B. Remove the 1/2" bolts from the uprights which hold the two legs together.
 - C. Remove the top leg. Do not stand legs up, instead lay the legs flat on their backs on the floor.

4. **Attach the cylinder mount or uprights.** Attach the cylinder mounts or uprights to the legs using four 1/2" X 1-3/4" bolts, washers and nuts as shown in figure 4.

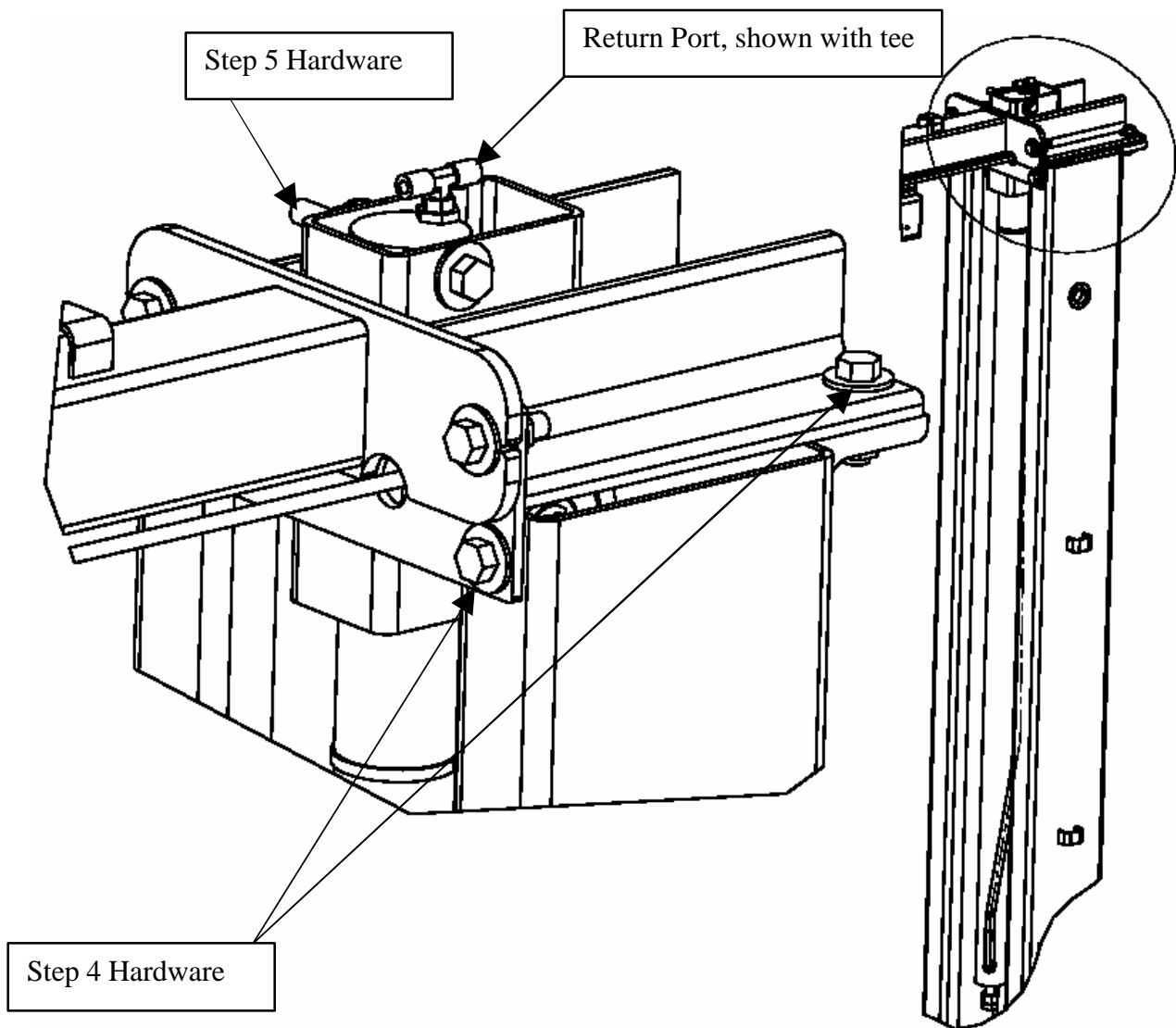

Figure 4

5. **Install hydraulic cylinders, fittings, hoses, and cables**

- A. **Warning:** When attaching hydraulic fittings with pipe threads to the cylinders use Teflon tape. **DO NOT start the Teflon tape closer than 1/8" from the end of the fitting.** Failure to comply may cause damage to the hydraulic system.
- B. **Warning:** When tightening connections with flared (JIC) fittings, always follow the following tightening instructions. Failure to follow these instructions may result in cracked fittings and / or leaks.
- * Use the proper size wrench,
 - * The nut portion of the fitting is the only part that should turn during tightening. The flare seat **MUST NOT** turn.

- * Screw the fittings together hand tight.
 - * Use the proper size wrench to rotate the nut portion of the fitting 2-1/2 hex flats.
 - * Back the fitting off one full turn.
 - * Again, tighten the fitting hand tight, then rotate the nut portion of the fitting 2-1/2 hex flats.
- C. Connect the hydraulic bushings and 1/4 push-in return line connectors to the return port of each cylinder.
- * Standard Height and High Rise Models - The tee should be attached to the mainside cylinder and the elbow on the offside.
 - * For Extended Height Models – Cut a piece of return line tubing equal to the length of the upright. Attach this piece of tubing to the mainside return port fitting, attach the tee to the other end of the tubing. Push the tee up through the top of the mainside upright. Run one end of the remaining tubing down through the offside upright and attach it to the offside return port fitting.
- D. Install the cylinders to the uprights or cylinder mounts with 1/2" x 4-1/2" Grade 8 bolts, **cylinder bushings (spacers)**, washers, and nyloc nuts, figure 4. The port near the rod end of the cylinders should be positioned pointing to the leg's open side. **High Rise** cylinders must be attached to the alternate hole near the top of the upright.

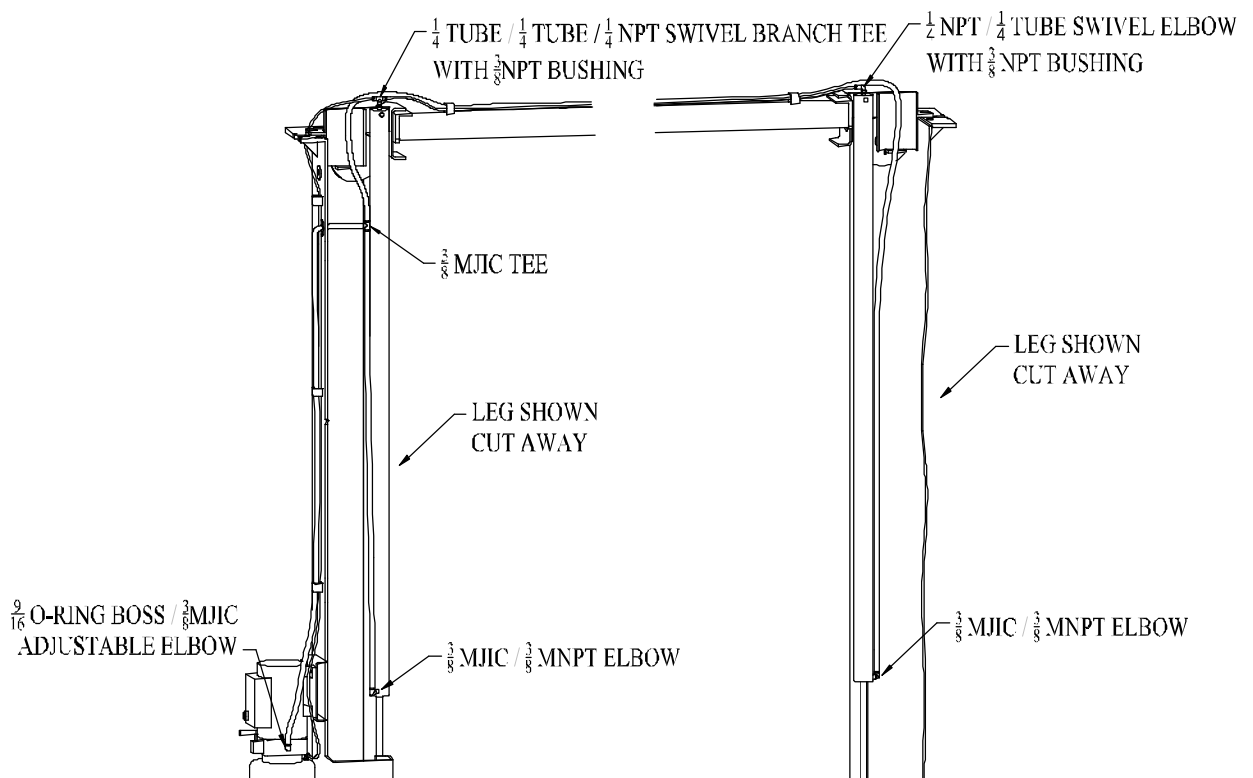

Figure 5

- E. Connect the shortest hydraulic hose to one of the runs on the JIC tee fitting.
- F. Connect the longest hydraulic hose to the other run on the JIC tee fitting.
- G. Connect the remaining hydraulic hose to the branch on the JIC tee fitting.
- H. Install the rubber grommet into the hole in the mainside leg.
- I. Connect a male pipe thread to male JIC elbow to the port near the rod end of each cylinder. The fittings should face away from the leg's baseplate.
- J. Connect the free end of the shortest hydraulic hose to the elbow on the cylinder in the mainside leg. This connection should be hand-tight only.
- K. Feed the shortest remaining hose through the rubber grommet, from inside the leg out. Feed this hose down through the hose guide welded to the outside of the leg. This hose will attach to the power unit.
- L. Feed the long hose through the cylinder mount or upright tube along the cylinder and out the end.
- M. Feed one end of an equalization cable down through the rightmost hole in the carriage top, figure 6. Continue to feed the cable until it extends out the bottom of the carriage. Attach a nylon insert locknut and washer to the end of the cable so that 1/8" of cable stud extends past the end of nut. Pull the opposite end of the cable until the washer contacts the carriage top. Repeat for the other cable/carriage.

ATTACH THIS CABLE, WASHER, AND NUT TO
CARRIAGE TOP PRIOR TO ASSEMBLING
CYLINDER TO CARRIAGE AND STANDING LEG UP

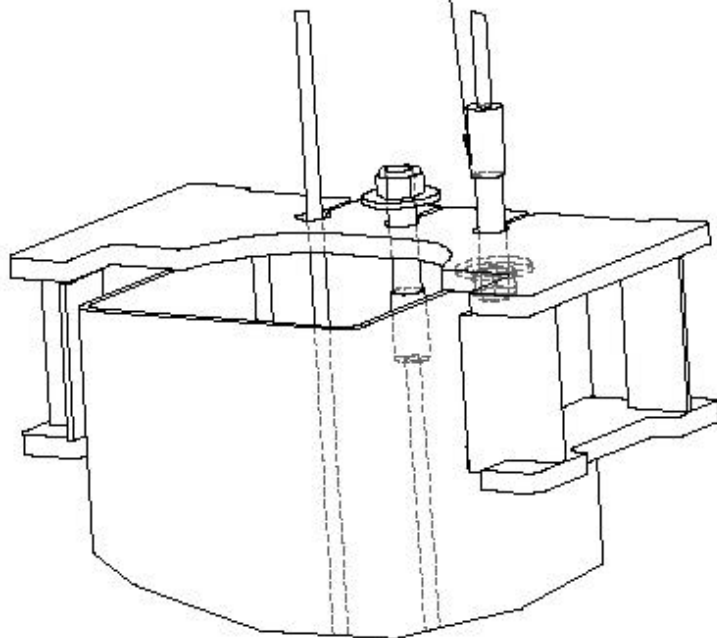
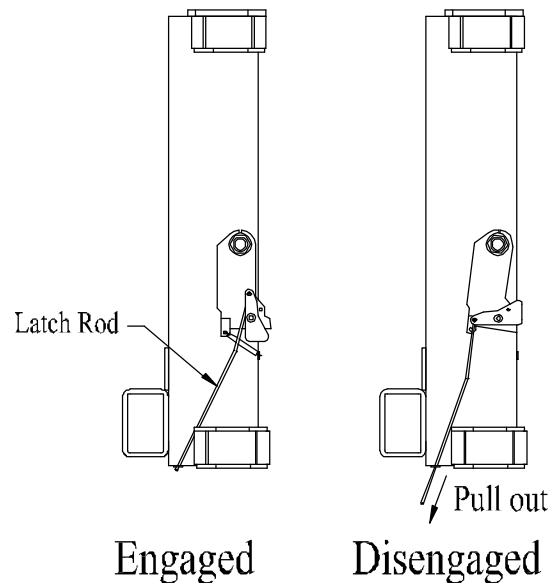

Figure 6

N. Attach the cylinders to the carriages. Make sure the snap ring on the cylinder rod is in the groove. Taking care not to damage the threads on the cylinder rod, pull carriage up to the cylinder and feed the rod through the hole in the carriage plate until the snap ring contacts it. Attach the full nut to the rod and tighten until the cylinder rod turns. Hold the full nut with a wrench and tighten a jam nut against it. Repeat for the other cylinder.

* **Do not hold the cylinder rod in a way that could damage the finish.
Cylinder leaks caused by damaged rods are not covered by warranty.**

6. **Carriage Placement.** Disengage the latch by pulling out the latch rod at bottom of one carriage, figure 7. Slide the carriage to the leg's baseplate. Engage the latch by pushing the latch rod in. Slide the carriage up until the first "click" is heard. Repeat the process for the other carriage.



SAFTEY LOCK

Figure 7

7. **Leg positioning and anchoring**

- A. ***Raise the Mainside leg only*** and position it where it is to be secured, figure 2.
- B. The anchor bolts must be installed at least 5-11/16" from any edge or seam in the concrete
- C. The concrete must be at least 4-1/4" thick with a compressive strength of 3,000 psi.
- D. Using the leg as a template, drill the anchor bolt holes for the **Mainside Leg Only!!**

* Use a hammer drill with a Carbide tip, 3/4" diameter, solid drill bit. The bit tip diameter should be to ANSI Standard B95.12-1977. (.775" to .787").

- * Keep the drill perpendicular to the floor while drilling.
 - * Let the drill do the work. Do not apply excessive pressure.
 - * Lift the drill up and down to remove dust and reduce binding.
 - * Drill the hole completely through the slab.
 - * Clean the dust from the hole.
- E. Assemble the washers and nuts onto the anchor bolts. Thread the nuts onto the anchor bolts where the tops of the nuts are just above the top of the bolts, figure 8. Using a hammer, carefully tap the anchor bolts into the concrete until the washer rests against the baseplate. Do not damage the nuts or threads.

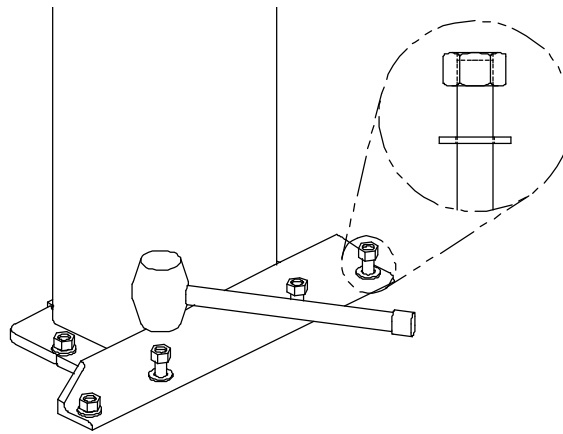

Figure 8

- F. Using a level, plumb the mainside leg both side to side and front to back. Shim the leg as necessary next to and on both sides of the anchor bolts, figure 9. If more than 1/2" of shimming is required, **do not** use the anchors and shims provided with the lift. Use longer anchors and fabricate larger shims from steel flat, 1/4" or 1/2" thick by 2", or more, wide.

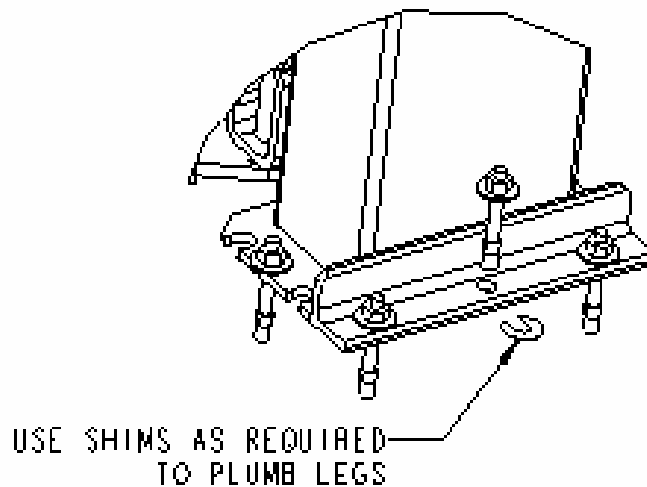

Figure 9

G. Once the leg is plumb tighten the anchor bolts to 150 ft-lbs. **Do not** use an impact wrench on anchor bolts.

* If after tightening the anchor supplied with the lift extends more than 2-1/4" above the floor the anchor does not have enough embedment.

* **If an anchor will not reach 150 ft-lbs or does not have enough embedment or adequate spacing cannot be achieved, replace the concrete under the leg with a 4' X 4' X 6" thick pad of 3,000 psi concrete keyed under the existing floor. Let the concrete cure before reinstalling the lift.**

H. Recheck the leg's plumbness after tightening the anchor bolts. Add shims if necessary.

I. Raise the offside leg and position it where it is to be located, figure 2. **Do not drill holes for anchors.**

8. Overhead assembly

A. **Single Phase Instructions, for 3-Phase instructions see 3-Phase kit.**

* Using (2) 1/4-20 X 1/2 HHCS and (2) 1/4-20 Flange Lock Nuts attach the overhead switch assembly to the overhead beam as shown in figure 10.

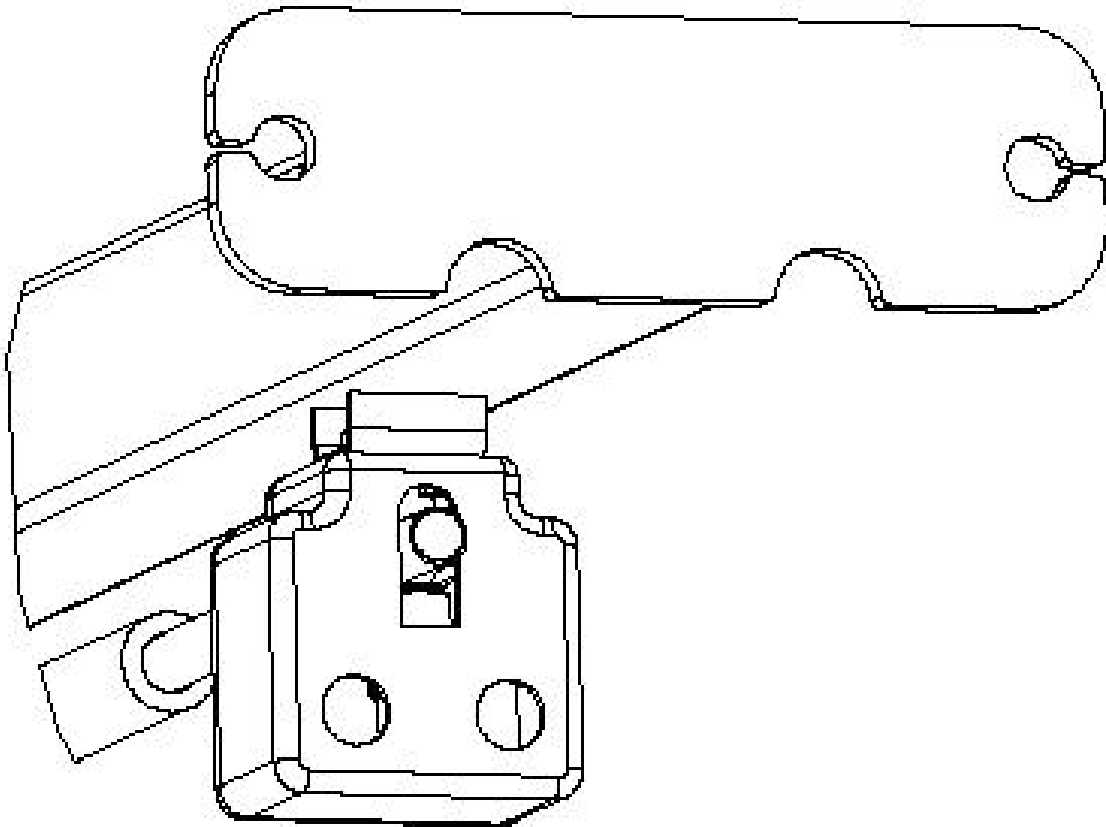

Figure 10

- * Slide the end of the padded switchbar without a mounting hole in it through the slot in the overhead switch assembly. Connect the padded switchbar to the inside hole in the overhead beam using a cylindrical spacer, $\frac{1}{4}$ -20 X 1-3/4 HHCS, and Flange Nut, figure 11.

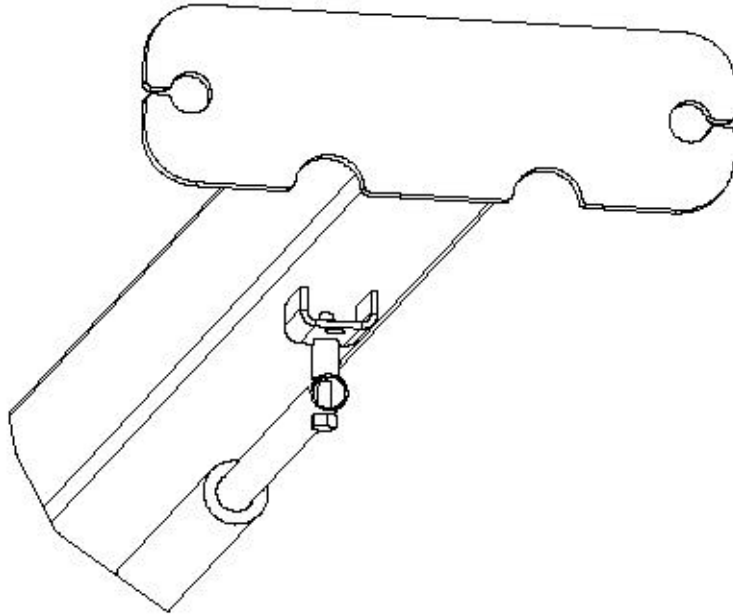

Figure 11

B. Attach the overhead beam to the cylinder mounts or uprights.

- * Raise the overhead beam and secure it to the cylinder mount or upright using two $\frac{1}{2}$ x 1-3/4 bolts, washers and nuts on each end, Figure 11.

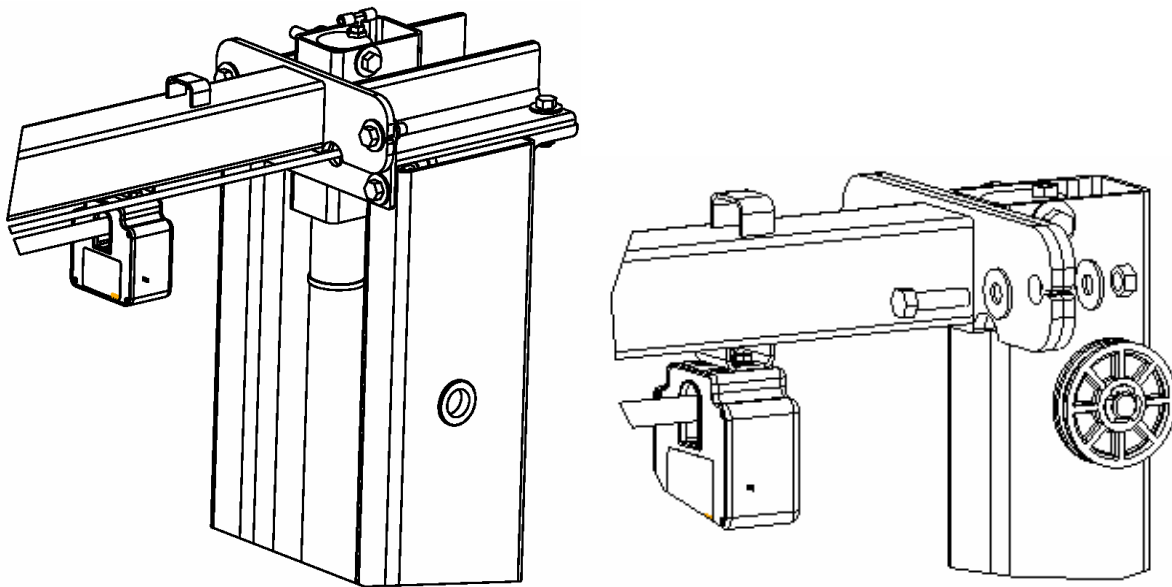

Figure 11

9. Anchoring offside leg

- A. Using a level check the alignment and plumbness of the entire structure. Plumb the offside leg both side to side and front to back.
- B. The base of the leg may vary from the preliminary layout, as it is more important that the leg be perpendicular to the floor and parallel to the other leg.
- C. Install the anchor bolts and shim the base as described in the earlier “Leg positioning and anchoring” step.

10. **Routing carriage equalization cables and offside hose, Figure 12.**

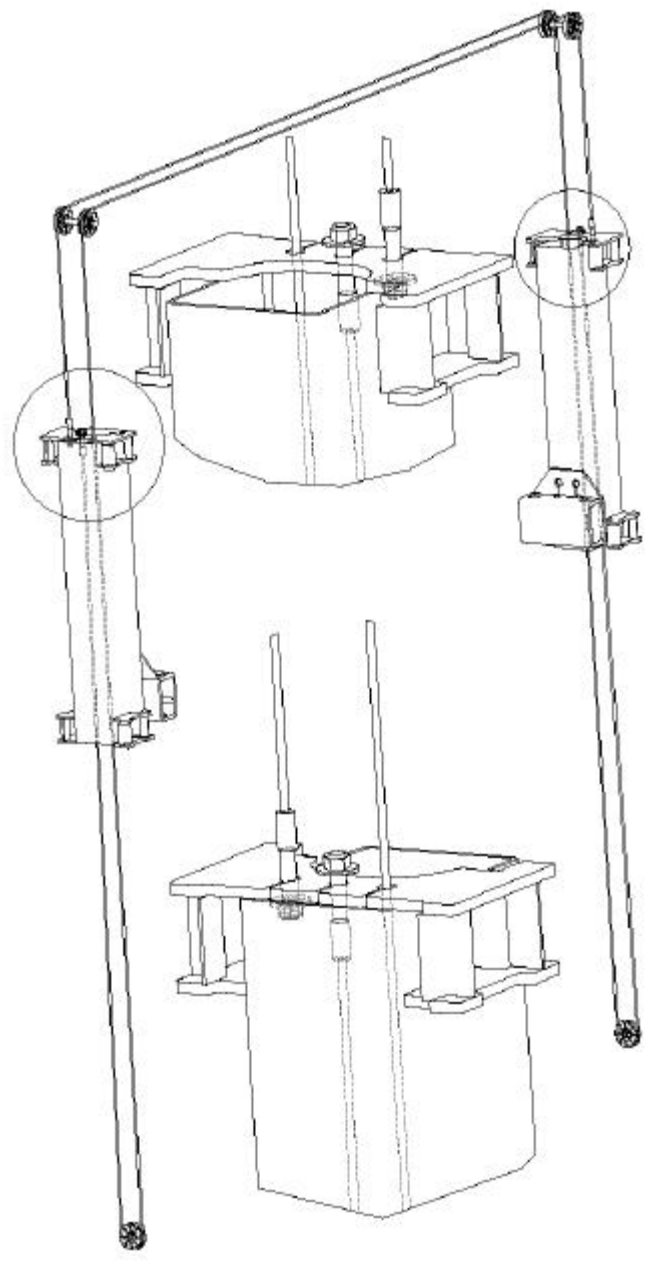

Figure 12

- A. The carriages should be resting on the same safety rack tooth. Measure the height above the baseplate for each carriage. The measurements should be within 3/8" of each other. Make a note of the two measurements.

- B. One end of each cable should already be attached to each carriage. Feed the other end of the cable up behind the mainside hose and through the top of the leg as shown, Figure 13,

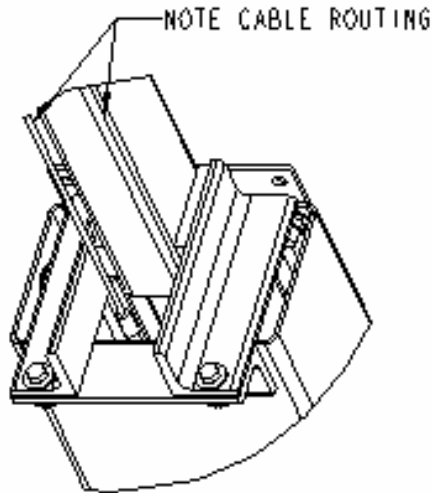

Figure 13

- * around the sheaves on the uprights,
 - ⇒ (while in the elevated position feed the offside hose through the hose guides welded to the top of the overhead tube and down through the offside upright tube.)
 - * feed cable through the clearance hole in the left hand corner of the carriage top,
 - * around the sheave at the bottom of the leg,
 - * through the hole in the center of the carriage top.
- C. Secure the cable end to the carriage top with a nylon insert nut and washer. **Do not tighten** the cable at this time.
- D. Repeat the process for the other cable, taking care not to cross them.
- E. Take out the slack, but do not tighten, in both cables by turning down the nuts on the top of each carriage top. Use vise grips to hold the cable end, but be very careful not to damage the threads.
- F. The carriages must remain at the same lock position while the cables are being tightened. Overtightening of one cable could raise the carriage in the opposite leg and cause the carriage safety latches to be out of sync.
- G. Alternately tighten the cable nuts at both carriages until the cables are tightened. Correct tension in the cables is indicated by being able to pull the cables together with approximately 15 pounds of effort at their midpoint in the leg.
- H. Measure and compare the carriage heights to the earlier measurement, or check that the safety latch pull rod will not disengage to verify that neither carriage has been

raised. If a carriage has been raised more than 1/8", loosen the cables and repeat the procedure.

- I. If the cables are installed correctly, both carriages will raise together. If equipment capable of lifting the carriages is readily available, lift one of them just enough to pull out the safety latch pull rods under both carriages and carefully lower to the ground. This will simplify the cylinder bleeding procedure.
11. **Mounting the power unit.** Attach four 5/16" x 1-1/4" bolts to the highest two and lowest two holes in the mounting bracket with 5/16" plain nuts. Attach the power unit, to these bolts and secure with 5/16" nylon insert nuts.
12. **Hydraulic system, figure 5.**
- A. Install the plastic push-in plug into the small brass elbow on the power unit tank.
 - B. The right side of the power unit from the controls has one open port. Attach the o-ring elbow to this port with the open end up.
 - C. Attach the hose hanging from the rubber grommet at the top of the leg to the elbow on the power unit.
 - D. Attach the hose hanging from the offside upright to the elbow at the bottom of the offside cylinder hand-tight.
 - E. To prevent the carriages from rubbing the hoses, pull the hoses upward taking out any slack between the cylinder fitting port and the cylinder mount. Secure the hoses to the mainside cylinder with wire tie around the tee and the cylinder, the tee should be positioned to aim directly out through the grommet, figure 14. Secure the hose to the offside cylinder at approximately the same height with a wire tie.

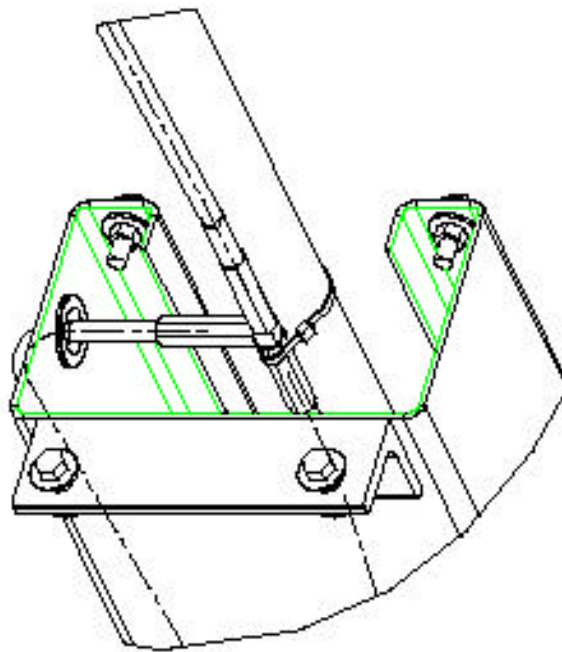

Figure 14

- F. Any excess hose should be taken up in the uprights, or at the corners between the uprights and the overhead.
- G. Add fluid. Remove the fill level screw near the top of the power unit tank. Remove the fill-cap from the tank and fill with Dexron III ATF or hydraulic oil that meets ISO-32, until fluid reaches the bottom of the screw hole. Replace the fill screw and tank breather.

13. **Electrical.**

A. Single Phase Instructions, for 3-Phase see the 3-Phase kit.

- * Have a certified electrician establish 208-230V, single phase, 60 Hz., 20 amp, power supply to motor and overhead switch, figure 18.
- * Use separate circuits for each lift.
- * Single phase motor cannot be run on 50 Hz. line without modifications in the motor.

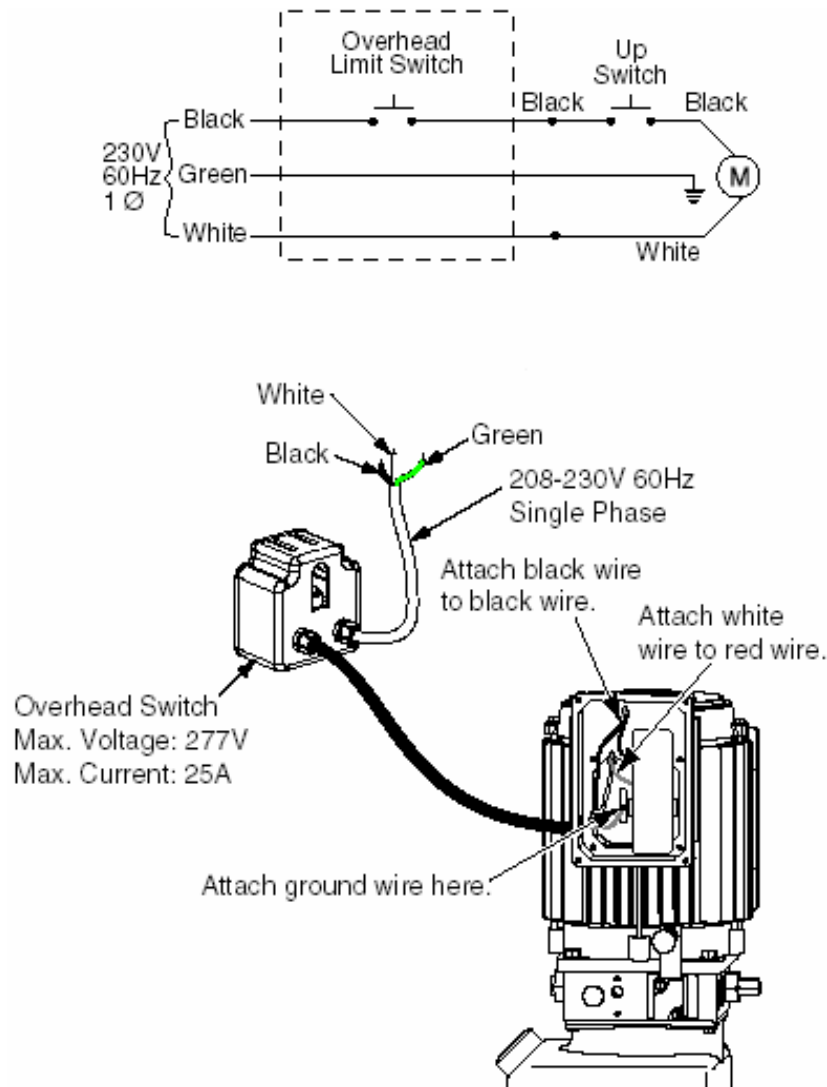

Figure 15

14. **Bleeding the hydraulic system, figure 4.**

- A. Loosen the connections **between the hoses and fittings** attached to the cylinders. **Do not** loosen the connections **between the fittings and the cylinders themselves**.
- B. Run the power unit until fluid appears at the mainside cylinder port. Tighten that hose connection.
- C. Run the power unit until fluid appears at the offside cylinder port and there is no more air. Tighten that hose connection.
- D. Lower the lift to the ground. If the lift is on the safety latches, raise the lift enough to disengage the latches and then lower.
- E. If the carriages were on the ground when the bleeding process was begun, no further bleeding is required. If not, repeat the previous steps for bleeding the hydraulic system.
- F. **Add fluid to the system as previously described.**

15. **Assembling the arms and arm restraints**

- A. Before installing the arms, install the restraint gears as follows.

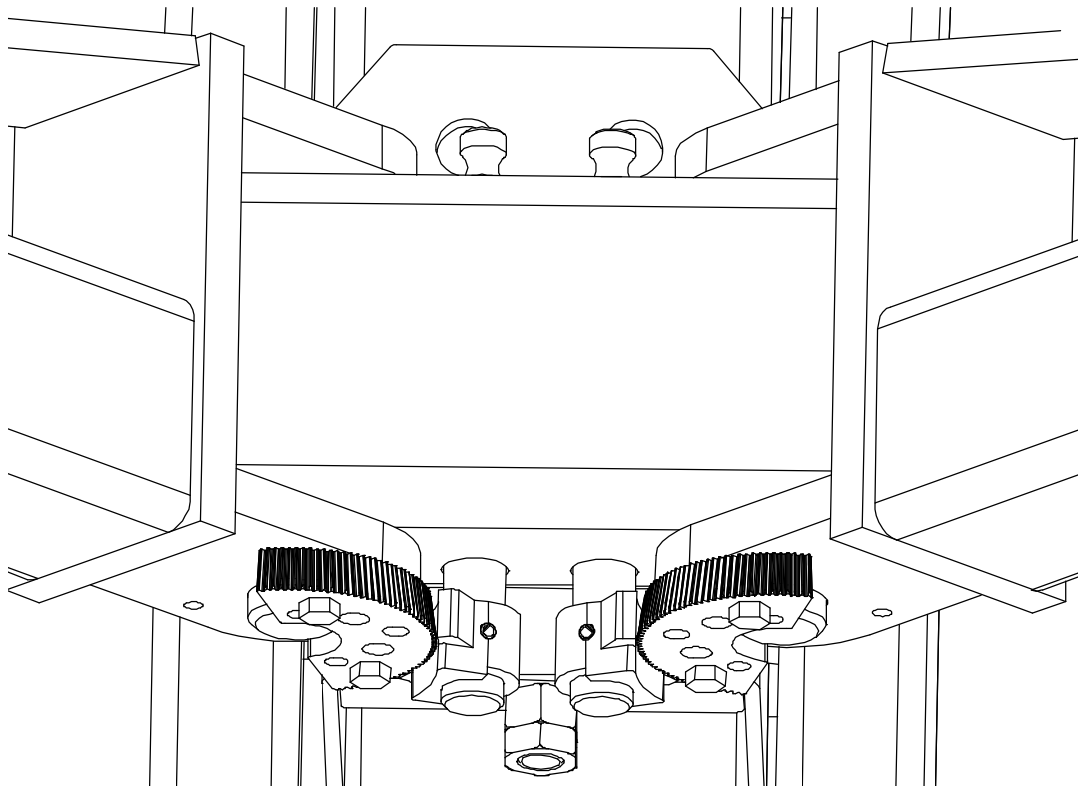

Figure 16

- B. Position the gears with word TOP against the bottom of the arms in the orientation shown in figure 16. Attach the gears to the arms with (2) 3/8-16NC X 1-1/2 long HHCS. Do not tighten at this time.

- C. Position the restraint pawls on the carriage to mate with the gears on the arms.
 - D. Install the swing arms and swing arm pins. If the arms are of different lengths, the longer arms go to the rear or drive in side of the lift, and the short arms go to the front, figure 2.
 - * Don't force the gears, it may be necessary to pull up on the restraint actuator pin in order to install the swing arm pin.
 - E. Tighten the gear bolts to 30-34 ft-lbs.
16. Lubricate the four inside corners of both legs with heavy duty bearing grease.

17. **Final Adjustments**

- A. Attach decals centered horizontally and 28" down from the top of the leg vertically on the most visible side of the lift. Do not install the decal directly above the power unit.
- B. If any problems are encountered, do not proceed with subsequent steps. Instead, resolve the problem before proceeding by referencing the Troubleshooting portion of the Owner's Manual section of this manual.
- C. Raise the lift to full height. Lower the lift onto the safety latches. Raise the carriages, pull out both latch pull rods, and lower the lift to the ground.
- D. Raise the lift **empty** to the top of its travel and lower it the floor three (3) times to remove the remaining air from the hydraulic system.
- E. The latches should click together as the lift is being raised.
- F. When the carriages are lowered onto the locks, neither pull rod should be capable of being pulled out.
- G. **The first time a vehicle is placed on the lift, raise it no higher than three feet.** Lower the vehicle onto the safety latches. Raise the lift a few inches and pull out both latch pull rods then lower the vehicle to the floor.
- H. Raise the vehicle to full height and lower the carriages onto the safety latches. Lower the vehicle to the floor.
- I. After cycling the lift ten times with a vehicle on it, recheck the tightness of the anchors to at least 90 ft-lbs.

Section 3 - Parts Breakdown

49	Cable and Lock Nut		89	Front Arm Slider, Short	
	5/8-11 Nylon Insert Locknut	913203		Asymmetric	1070631
	Standard Models	1070911	Symmetric	1070629	
	Standard Models, Extended Height, 2'	1072901	88	Rear Arm Slider, Long	1070629
	Narrow Model	1070914		Right Front Arm Tube Weldment	
	Narrow Model, Extended Height 2'	1072903	87	Asymmetric	1070625
48	Parts Box	994247		Symmetric	1080602
47	1/4" Return Line	992212	86	Right Front Arm Assembly	
46	Double Stack Bracket / Shim	1070909		Asymmetric	1070624
45	Hydraulic Kit			Symmetric	1080601
	Standard Models	994205	85	Left Front Arm Tube Weldment	
	2' Extended Height Models	994206		Asymmetric	1070623
	High Rise Models	107H900		Symmetric	1080602
44	Literature Bag	994255	84	Left Front Arm Assembly	
43	Single Phase Overhead Switch	0970902		Asymmetric	1070622
42	Cable Sheave	1070900		Symmetric	1080601
41	Small Parts Bag	1070907	83	1-1/2" Pad Extension	996220
40	Cylinder Mount / Upright Weldment		82	3" Pad Extension	995560
	Standard Ht.	1070801	81	6" Pad Extension	995550
	Extended Ht.	1072801	80	Arm Pin	995430
39	Cylinder Mount / Upright Assembly		79	Rub Block	995120
	Standard Ht.	1070800	78	Arm Restraint Gear Kit	994258
	Extended Ht.	1072800	77	Pad Extension Kit	994257
38	Overhead Weldment		76	Stack Swivel Pad Weldment Kit	994256
	Standard Models	1070803	75	2-Post Pressure Fitting Kit	994216
	Narrow Models	1070805	74	Swivel Pad Insert Kit	994105
37	Cylinder Bushing	0970804	73	3/8 JIC Tee	992502
36	Sheave Pin	0970802	72	9/16 O-Ring to 3/8 JIC Elbow	992410
35	Rear Arm Tube Weldment		71	3/8" Bushing to 1/4" NPT Bushing	992501
	Standard Asymmetric	1070620		Mainside Return Line Tee	
	Narrow Asymmetric or Symmetric	1080602		Standard Height and High Rise Models	992500
34	Rear Arm Assembly			Extended Height Models	992512
	Standard Asymmetric	1070619		Offside Return Line Fitting	
	Narrow Asymmetric or Symmetric	1080601		Standard Height and High Rise Models	992496
33	Carriage Weld	1070501		Extended Height Models	992504
32	Carriage Assembly	1070500	70	3/8 JIC to 3/8 NPT Elbow	992402
31	Mainside Leg Weldment	1070107	69	Cylinder	
30	Mainside Leg Assembly	1070106		Standard Rise	992317
29	Offside Leg Weldment	1070105		High Rise	992327
28	Offside Leg Assembly	1070104	68	Offside Hose	
27	1-1/4 SAE Washer	915206		Standard Height Models	992143
26	3/4" X 5-1/2" Anchor Bolt	913828		Extended Height Models 2'	992158
25	3/4-16 Hex Jam Nut	913611	67	Power Unit Hose	992101
24	3/4-16 Hex Nut	913602	66	Mainside Hose	
23	1/2-13 X 4-1/2 HHCS Grade 8	912781		Standard Rise	992156
22	1/2-13 X 1-3/4 HHCS Grade 5	912671		High Rise	992169
21	1/2 Washer	912605	65	Single Phase Power Unit	992017
20	1/2-13 Nylon Insert Lock Nut	912603	64	3/4 Klip Ring	991504
19	1/2-13 Hex Nut	912601	63	3/8 Klip Ring	991503
18	3/8-16NC HHCS	912061	62	Rubber Grommet	991491
17	3/8" Washer	912005	61	1/4-20 Flange Hex Lock Nut	991490
16	5/16-18 X 1-1/4" HHCS Grade 5	911751	60	3/8NC x 1/2" Lg. Self-tapping screw	991487
15	5/16-18 Nylon Insert Lock Nut	911703	59	Overhead Switch Bar, Single Phase	991481
14	5/16-18 Hex Nut	911701	58	Switch Bar Spacer	991480
13	1/4-20 HHCS X 2" Lg.	911481	57	1/4-20 X 1-1/4 Elev. Bolt	991243
12	1/4-20 HHCS X 1/2" Lg.	911421	56	Swivel Pad Rubber Insert	991234
11	1/4 Washer	911405	55	Shim	991127
10	1/4-20 Nylon Insert Hex Nut	911401	54	24" Wire Tie	991082
9	Latch Pull Rod	143540	53	Latch Spring	991071
8	Arm Restraint Spring	143537	52	3/16 Cap Nut	991070
7	Arm Restraint Actuator Pin	143536	51	1/4 Roll Pin X 1-1/2" Lg.	991060
6	Arm Restraint Pawl	143535	50	1-3/8 Snap Ring	991030
5	Arm Restraint Gear	143534			
4	N/A				
3	Stackable Pad Weldment	106605			
2	Latch Weldment	106502			
1	Latch Wipeout	070528			

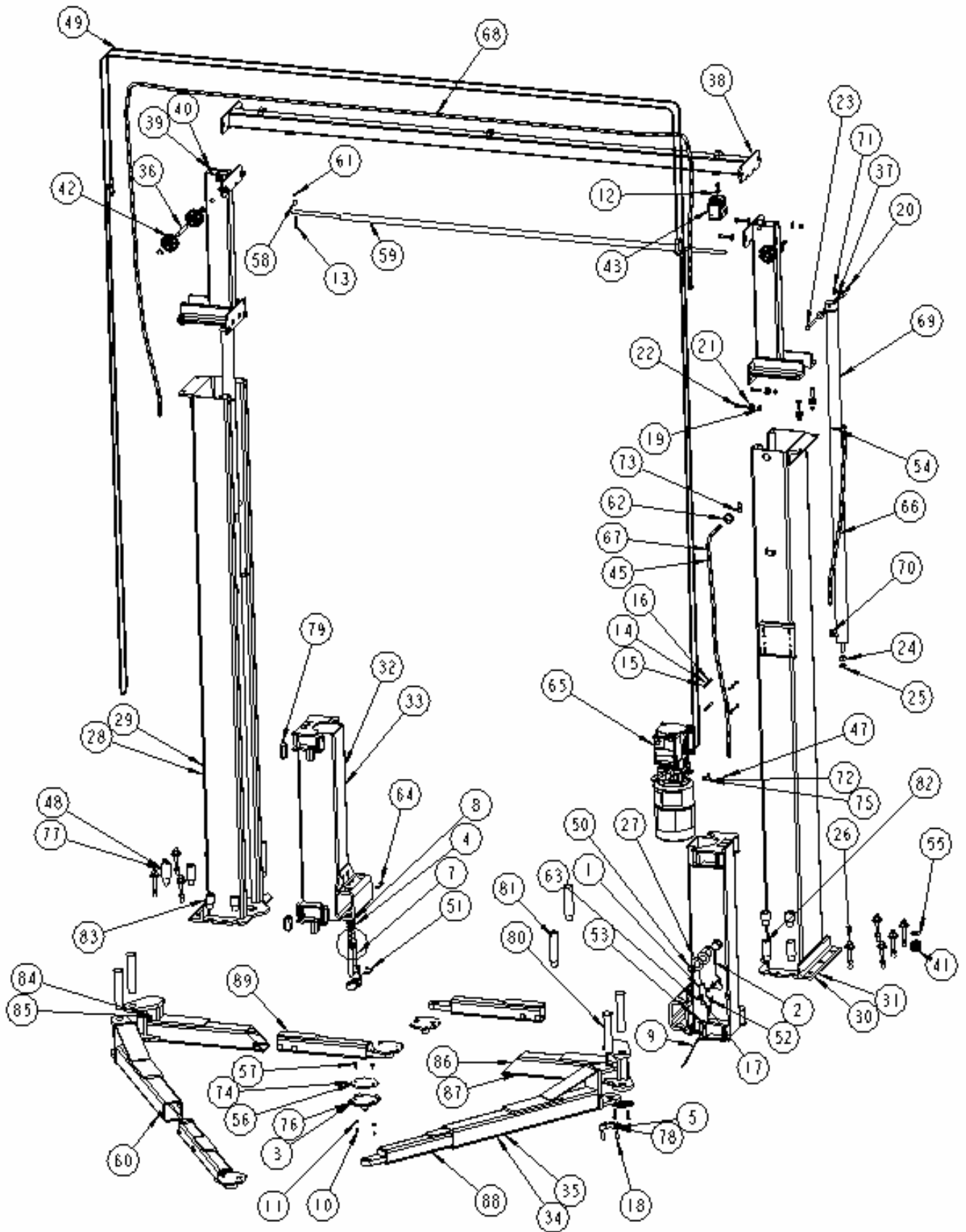

Figure 17