

MODEL 60K

Installation And Owner's Manual

(000Series)

Capacity 60,000 lbs. (30,000 lbs. per axle)
Four Post Surface Mounted Lift

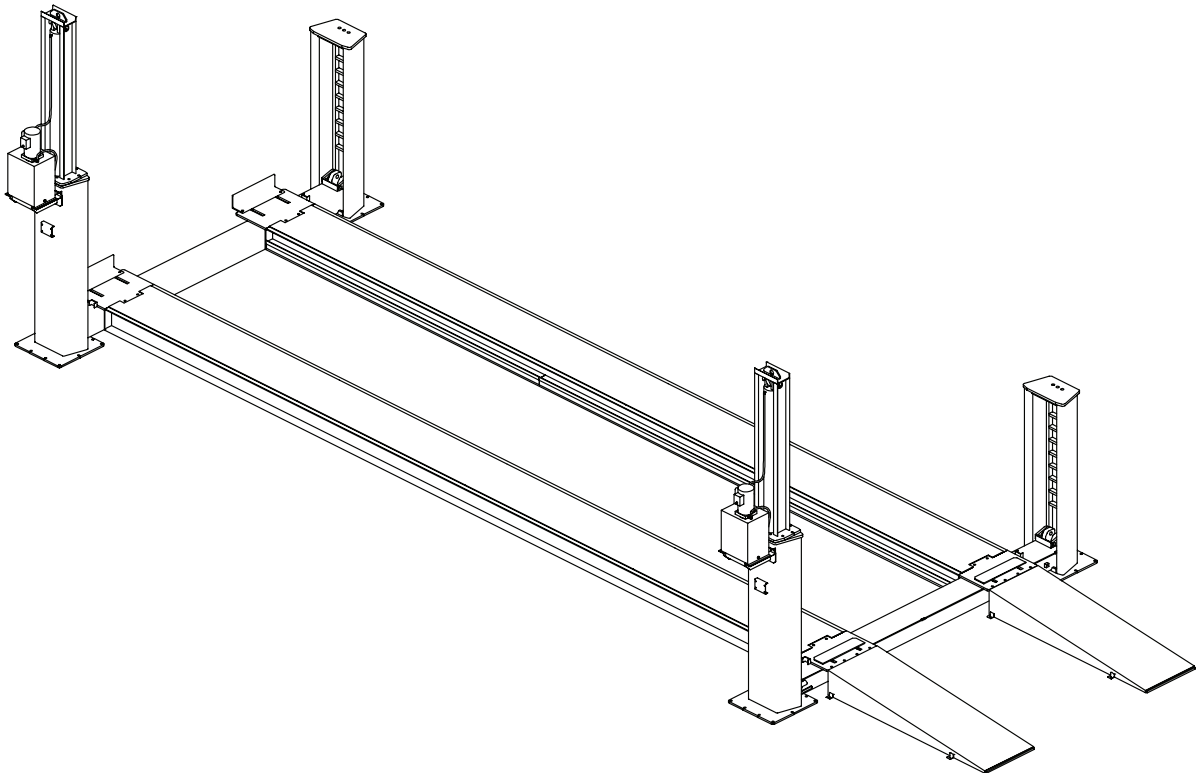

IMPORTANT This lift is wired and adjusted to operate at 230 volts.
If facility voltage is different, refer to set-up instructions.

The floor on which the lift is to be installed must be 5-1/2" to 6" minimum thickness concrete, with a minimum compressive strength of 3000 psi, and reinforced with steel bar.

IMPORTANT Failure by the purchaser to provide the recommended mounting surface could result in unsatisfactory lift performance, property damage, or personal injury.

The 60K lift requires a ceiling height of at least 16' - 0".

The standard lifts require 208/230V, 60 hz, three phase, 30 amp ac electrical service. Other electrical requirements are special order.

The lifts are Designed for indoor use only.

Read the anchor bolt instruction page before drilling and installing the anchor bolts.

This lift requires a certain installation procedure to reduce the amount of air trapped in the cylinders. Failure to follow the procedure will result in unsatisfactory lift performance.

Do not raise a vehicle on the lift until the lift has been correctly installed and adjusted as described in this manual.

Do not exceed the rated capacity of the lift. The lift is rated at 60,000 lb capacity.

Tools Required for Installation

Concrete hammer drill with 1/2" and 3/4" solid drill bit with carbide tip to ANSI Standard B94.12-1977.

Open end wrenches: 1/2", 9/16, 11/16, 3/4, 7/8, 1-1/16, 1-1/8, 1-13/16, or 16" crescent wrench.

Ratchet drive with sockets: 9/16, 7/8, 1-1/16, 1-1/8.

Hammer

Needle Nose Pliers

Snap Ring Pliers

Level

Pull wire or fish tape

Also Required for Installation

20 gal Dexron III ATF, or Hydraulic Fluid that meets ISO 32 specifications.

1. INSTALLATION:

- A. Determine the location for the lift installation. This lift can be used with the main side legs, which hold the cylinders and power units, positioned at either side as shown in Fig. 1. The operator with the controls will stand on the mainside of the lift, between the two legs. For this reason, the mainside of the lift should be positioned away from any walls or obstructions. Fig. 2 gives the overall standard dimensions of the lift, including the drive on ramps. The overall dimensions may vary due to ramp length. The area must be level and there must be free access to load and unload the vehicles. There must be enough overhead clearance to raise vehicles 6 feet above the floor. The floor must be concrete with a minimum thickness of 5-1/2" to 6" inches and steel reinforced per commercial practice. If pads are used, they must be 3'-0" square with a minimum thickness of 24 inches and steel reinforced per commercial practice. Fig. 3 gives the pad layout dimensions.
- B. Refer to Fig. 3 to get the dimensions for the leg foot locations. Refer to Fig. 2 to determine where to locate the sides and ends of the leg foot rectangle with respect to walls and other obstacles at the installation. Include additional clearance where required near walls and obstacles.
- C. Once the location is determined use a chalk line to make base line A-B to locate one side of the lift, Fig. 4. Use the width dimension of 15' - 6" to measure off the dimensions A-D and B-C. Draw arcs as illustrated in Fig. 4. Draw a chalk line D-C tangent to the two arcs to establish the other side of the lift.

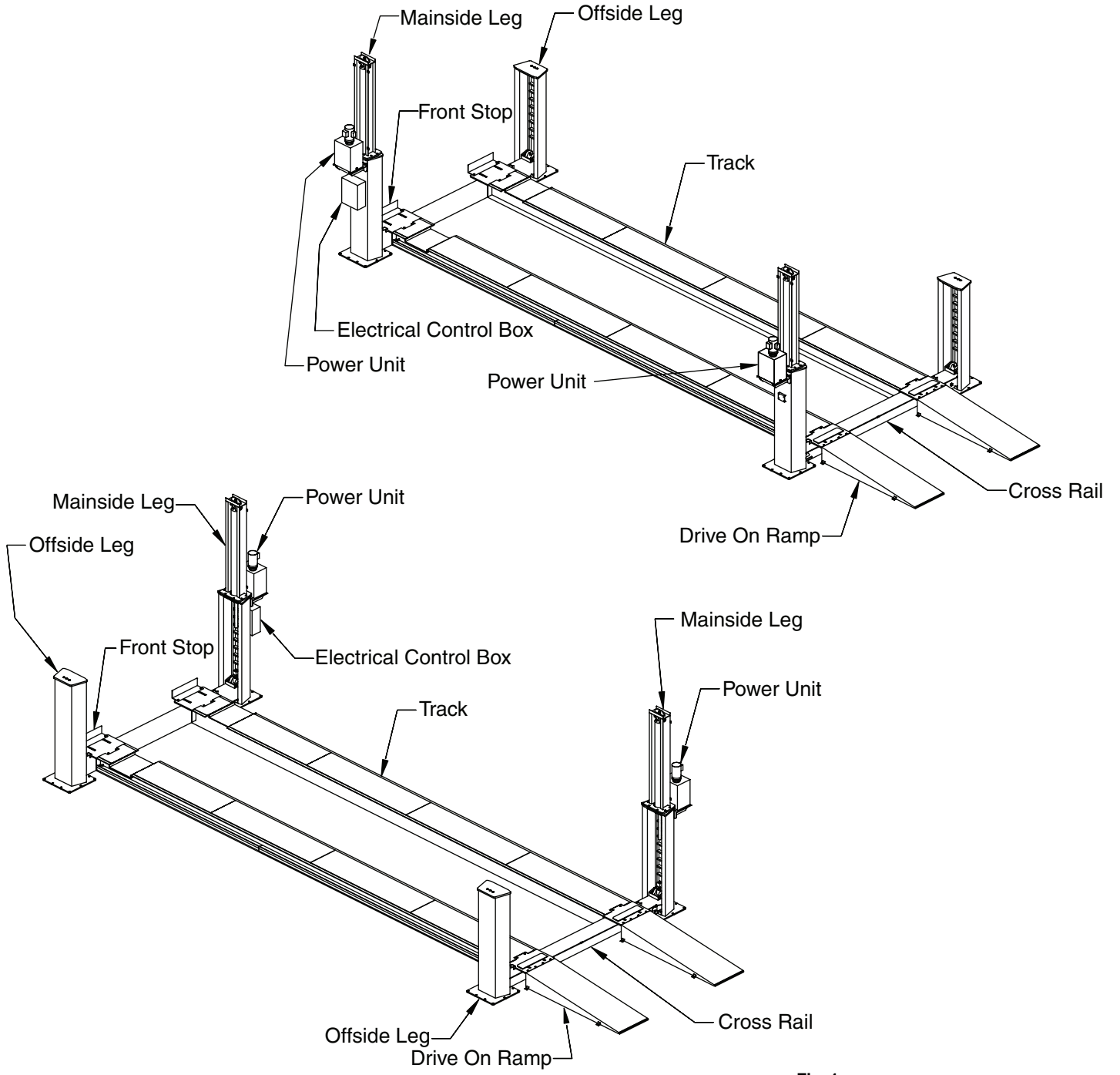
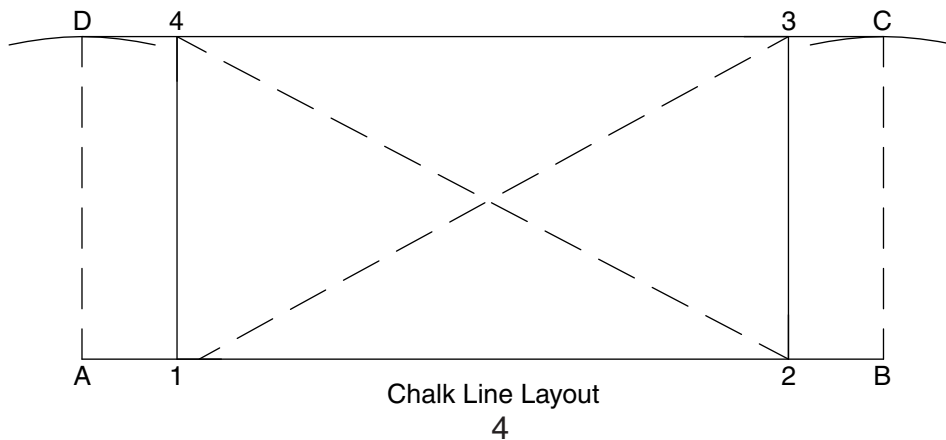
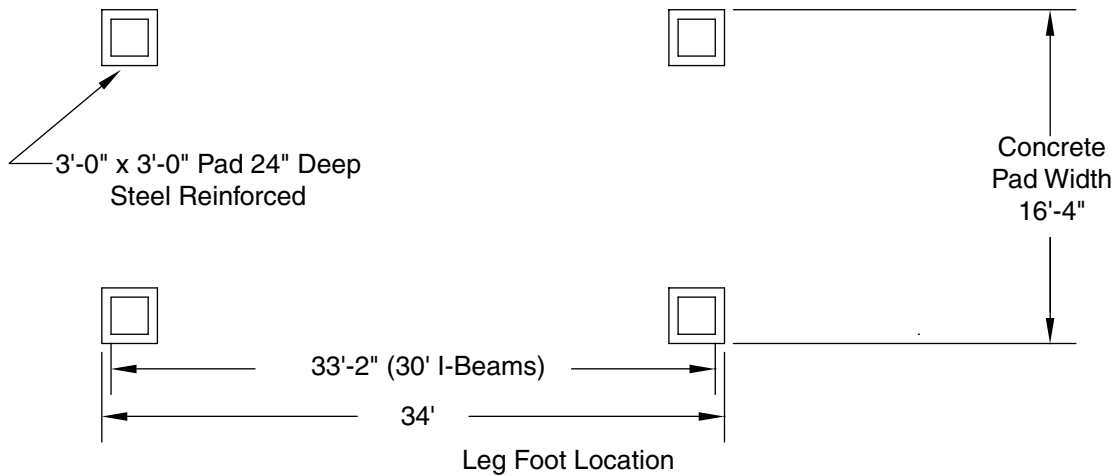
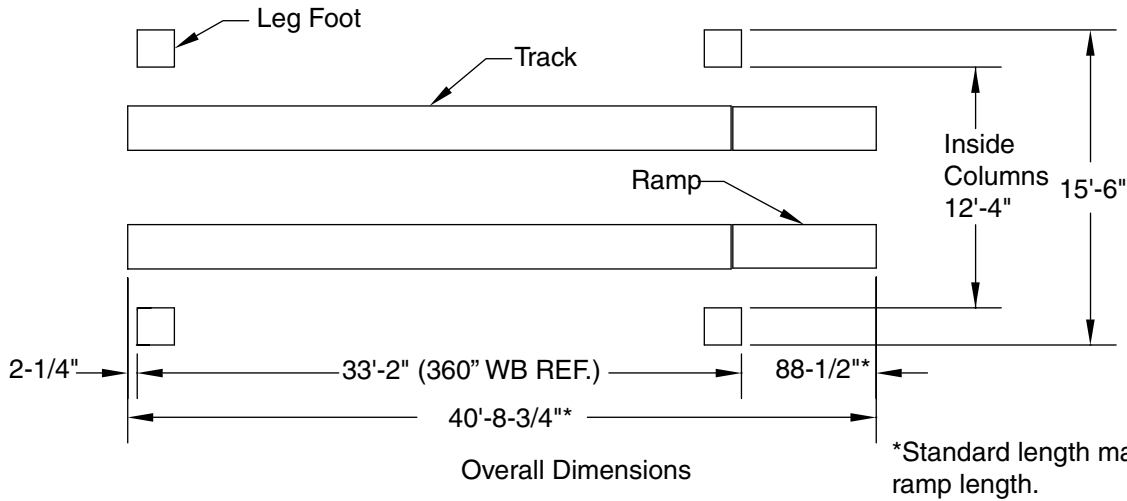

Fig. 1

D. Mark on one of the two parallel lines the Points 1 and 2 to establish the ends of the leg foot rectangle as determined from Figures 2(a) and 3(a). From points 1 and 2 measure diagonally to the opposite parallel line to determine points 3 and 4. Draw a chalk line between points 1 and 4 and points 2 and 3. The four lines locate the four outside corners of the leg foot rectangle.

E. Stand at the end of the rectangle which will be drive on entrance to the lift. As you face the way the vehicles will enter the lift, the side you want the power units on will be the Mainside of the lift. This side will be where the mainside legs, cylinder mounts, and power units will be located. The end opposite you is the front, where the front of the vehicles stop. The end where you are is the back of the lift, where the drive on ramps are installed, Fig. 1.

30' BEAM LIFT



- F. Position the two mainside and the two offside legs as shown in Figure 1. Make sure that the legs are positioned correctly and square with the installation location.

36' BEAM LIFT

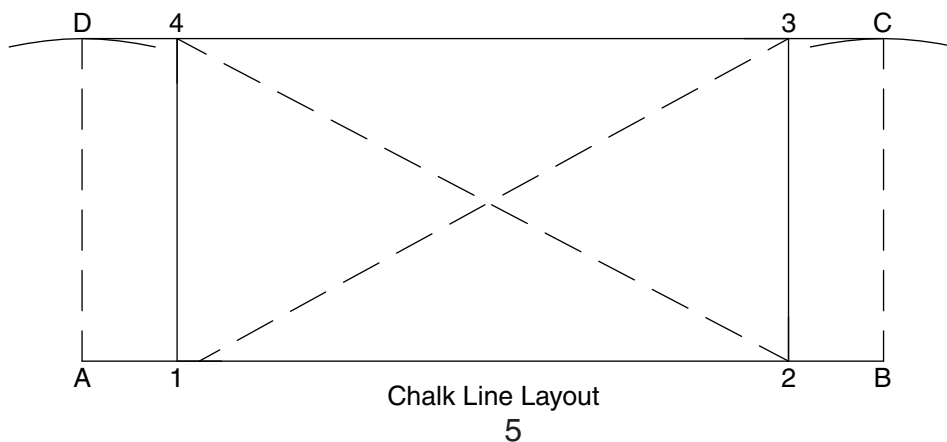
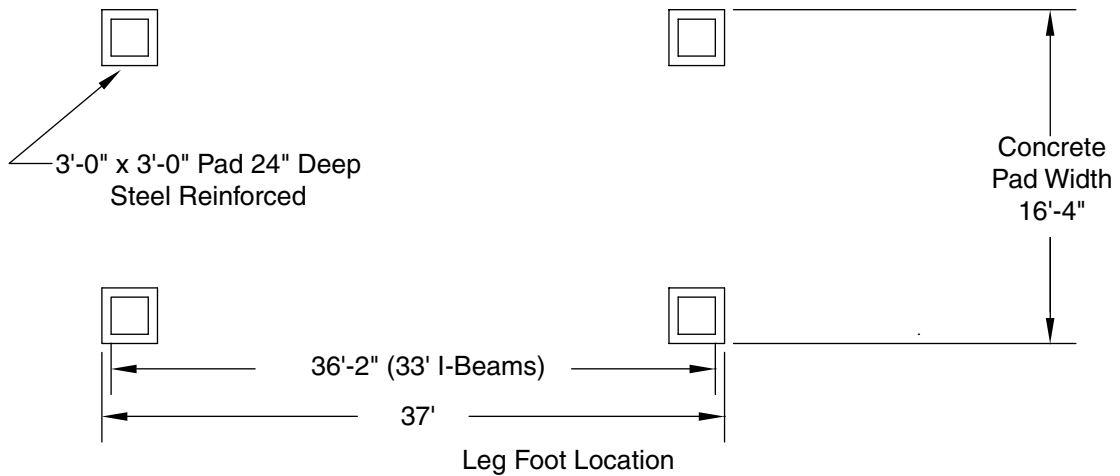
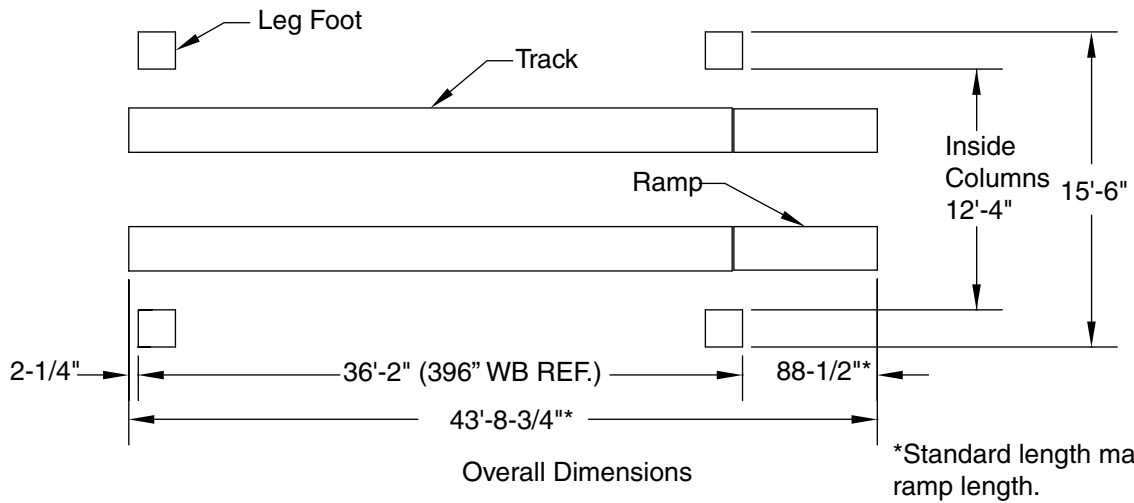

2. Anchoring:

- A. Review the concrete anchor bolt instructions. Drill, install, but do not tighten the 20 anchor bolts for the two mainside legs.

IMPORTANT DO NOT drill or set offside leg anchor bolts at this time. The lift must be correctly aligned and cycled before the bolts are installed.

- B. Refer to Figure 5, Mainside Leg and Cylinder Mount Shimming. Check the plumbness of the legs as shown. Shim as required and tighten the anchor bolts. Re-check the legs after tightening the bolts. Next, check the plumbness of the Cylinder Mounts Fig. 5. If required, loosen the mounting bolts, shim between the mounting plates as required, and retighten the bolts. Recheck the cylinder mounts after tightening.

3. Drilling And Installation Procedure:

- A. The anchor bolts must be installed at least 5" from any edge of the concrete or any seam.
- B. Use a carbide tip, solid drill bit, 3/4" diameter. Tip diameter to ANSI standard B94.12-1977. (.775" to .787").
- C. Use a concrete hammer drill only!
- D. Do NOT use excessively worn bits or bits which have been incorrectly sharpened.
- E. Keep the drill perpendicular line while drilling.
- F. Let the drill do the work. Do NOT apply excessive pressure.
- G. Lift the drill up and down to remove dust and reduce binding.
- H. Drill the hole completely through the slab.
- I. Blow out the dust from the hole. This increases the holding power.
- J. Assemble the washer and nut onto the anchor bolt. Thread the nut approximately 4/5's of the way onto the anchor bolt where the top of the nut is just above the top of the bolt. Using a hammer on the nut, carefully tap the anchor bolt into the concrete. Do NOT damage the nut and threads.
- K. Tap the nut and bolt so the washer rests against the base of the lift.
- L. Tighten the nut two or three turns using hand tools. Do NOT use an impact wrench on anchor bolts.

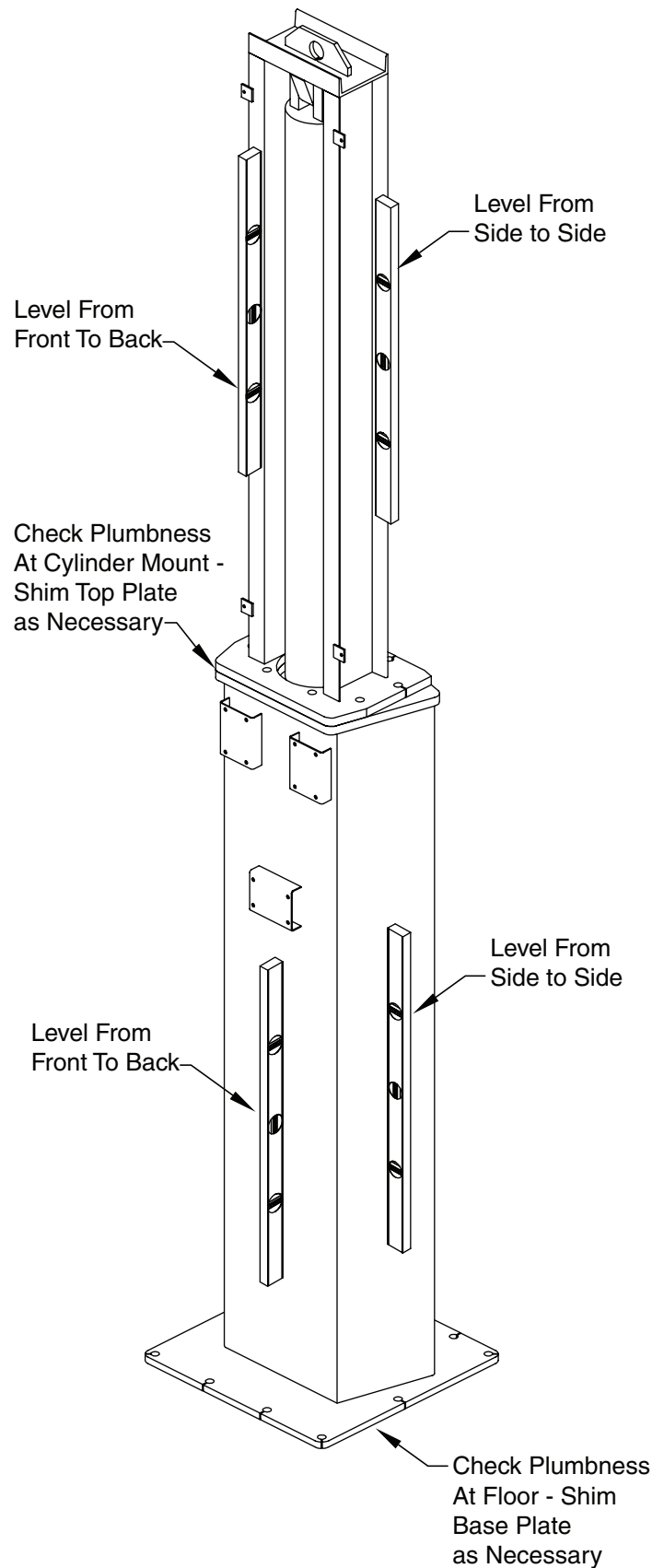

Fig. 5

WARNING If the nut is not flush with the top of the stud in the area underneath the safety latch lever, it will bend the lever, when the lift is fully lowered.

IMPORTANT At this time check the safety latch linkage on each crossrail for correct operation. Pull the lever down until it locks, Fig. 6. The latches at the ends of the crossrail will lock in the released position. If the mechanism does not work correctly, check for damage or misalignment and correct. Repeat for both crossrails.

4. Crossrail Installation:

- A. Prepare to position crossrails in their approximate locations as shown in Figure 1. The cylinder connector must be at the mainside leg locations. The safety latch release levers must be to the outside of the lift and at the mainside leg side, Fig. 6.

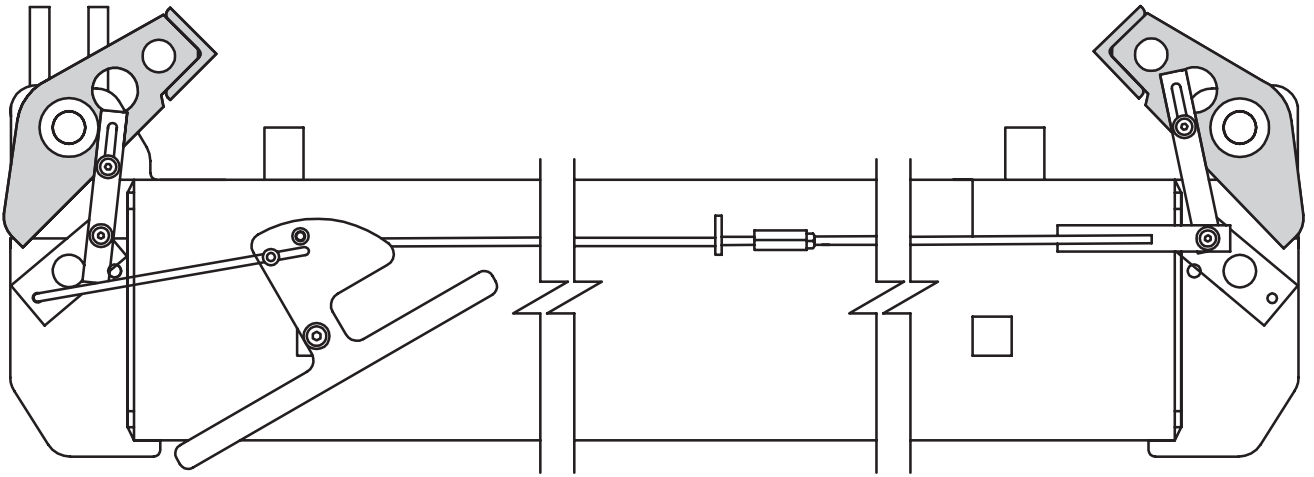

Release Position

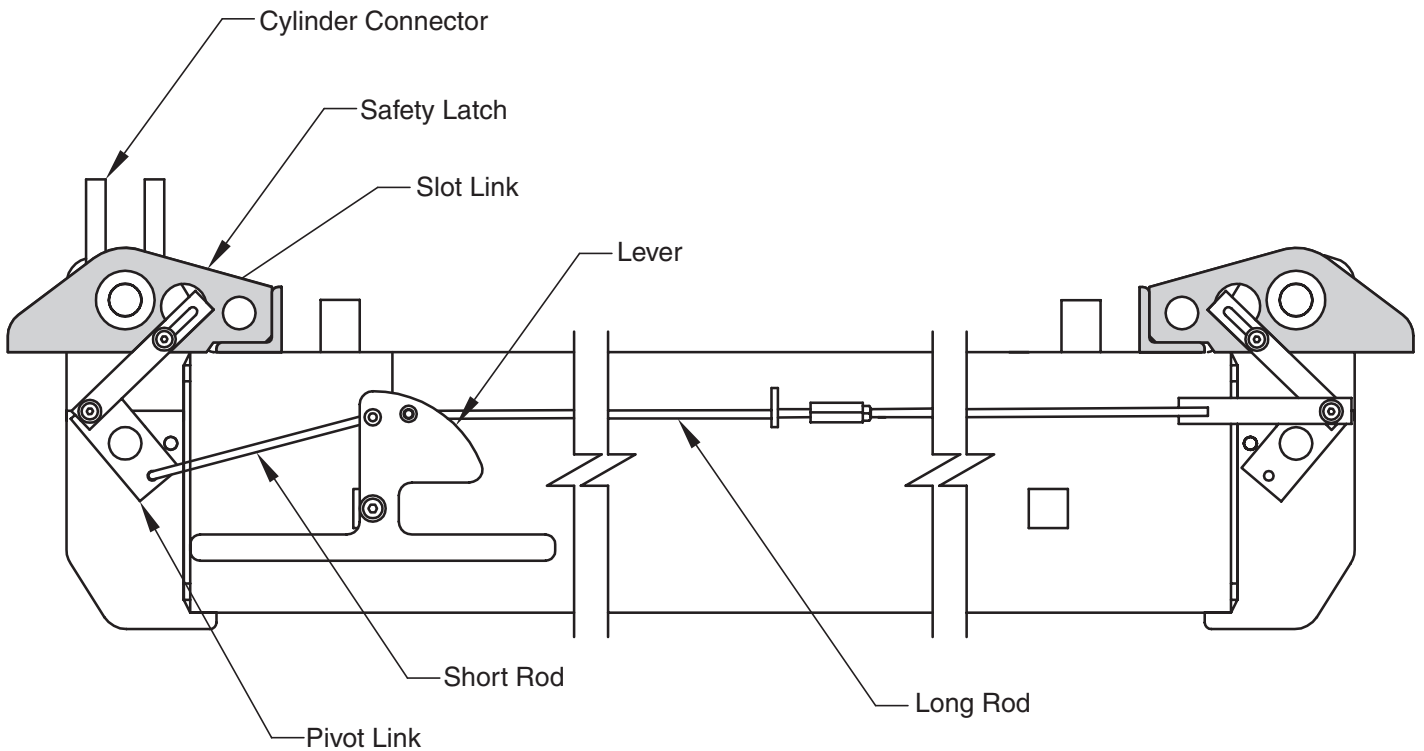

Latch Position

Fig. 6

- B. Use the pull wire to pull the three crossrail chains through the crossrail tube. The chains run over the sheaves at the mainside end and under the sheaves at the offside end, Fig. 7. Repeat for the other crossrail.
- C. Using a forklift, position the rear crossrail between the two legs. With the crossrail 1' above the ground, attach the crossrail chains to the mainside leg chain anchor with the three 3/8 x 2-1/2 Grade 8 hex head bolts and 3/8 nylock nuts. Install the stud ends of the chains into the holes at the top of the offside leg. Install the 1-1/8 washers and nylock nuts to the studs. Hold each chain with a crescent wrench while tightening the nuts. While holding the crossrail level, remove the slack from both chains.

IMPORTANT The chain anchor bolts must be a grade 8 hardened bolt, 3/8 diameter by 2-1/2" long. Failure to follow this requirement could result in bolt failure with possible personal injury and property damage.

- D. Continue to support the crossrail with the forklift. Remove the caps from the cylinder ports on the rear leg cylinder. Pull down the connector on the rod end to the cylinder block on the crossrail. If the rod will not pull down, attach the long hose to the top port, and carefully apply compressed air to the hose end by holding a hand nozzle to the opening. Do **NOT** allow the rod to shoot downwards. Line up the holes in the two connector blocks and insert a 1-1/2" diameter by 5-1/8" pin. Install a 1-1/2" diameter snap ring in the groove on the back of the pin. Lower the crossrail to the ground. Install a 1-1/2" diameter snap ring thru the hole in the leg back into the inside groove on the pin, Fig. 8.

- E. Repeat the procedure with the front crossrail.

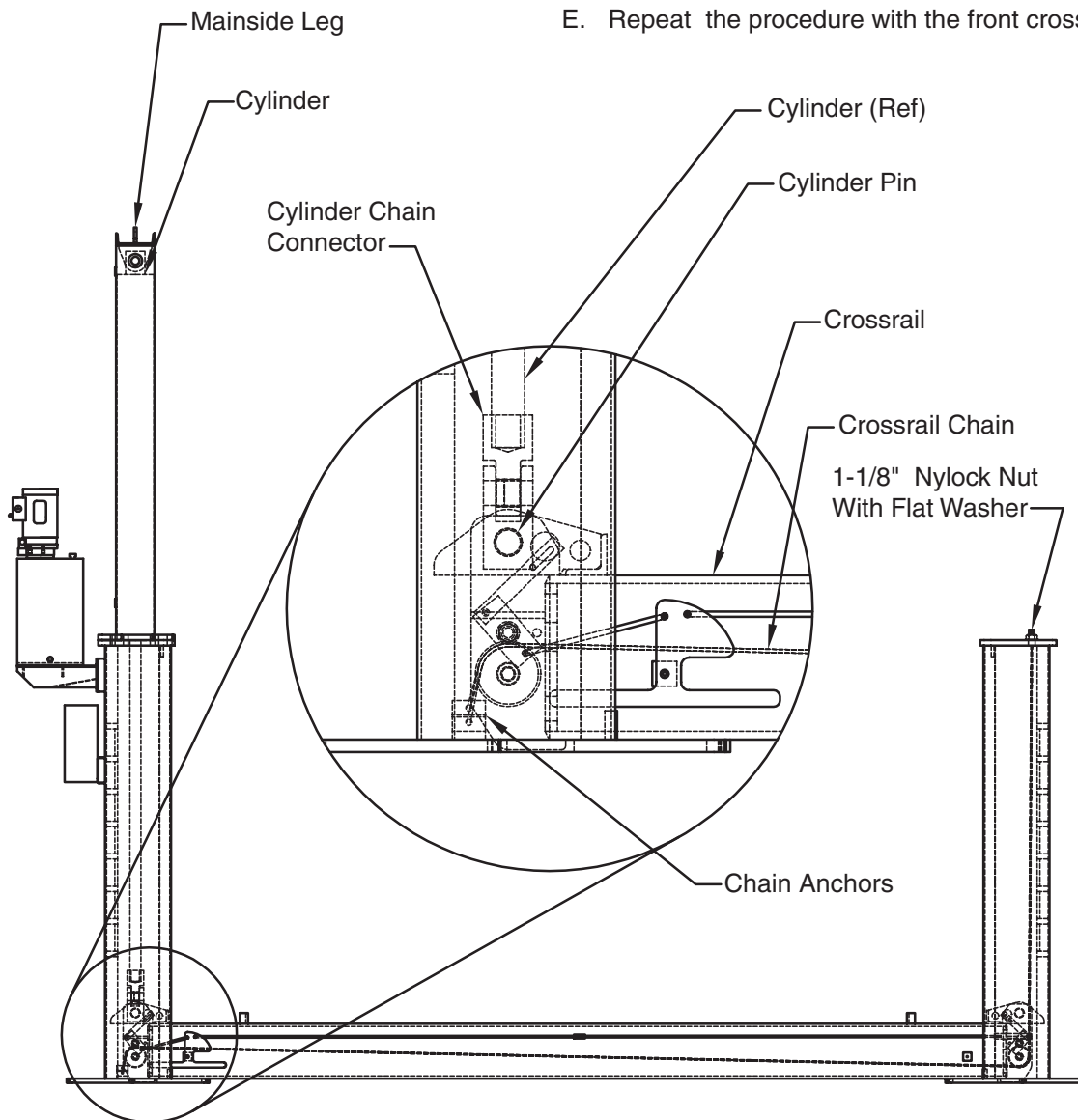

Crossrail Chain Arrangement

Fig. 7

IMPORTANT Position Crossrail Assemblies With Safety Latch Release Levers To The Outside Ends Of The Lift And At The Mainside End Of The Crossrail.

- F. Position the tracks on the crossrails. The tracks should be centered on the rails with 40" between them. The jack tracks should be to the inside of the tracks. There should be approximately 1/2" between the ends of the tracks and at each crossrail tube.

5. Power Unit Installation:

- A. Install the male pipe to 3/8 male JIC 90 degree fittings into the cylinder ports. The top fitting should point downward. The bottom fitting should point directly to the left. Use teflon pipe tape on these pipe fittings. Start the teflon no closer than 1/8" to the end of the fitting.
- B. Bolt a power unit mount bracket to each of the two mainside legs on the top mounting plates. Mount a power unit on top of each bracket with the 5/16 x 1 bolts and 5/16 nylon insert nuts. Install the power unit fittings. The pressure port uses a 9/16 O-ring to 1/2 male JIC straight fitting with an attached 1/2 JIC 90 swivel. The return port uses a 3/8 male pipe to 1/2 JIC straight fitting with an attached 1/2 JIC 90 swivel. Refer to Fig. 9.

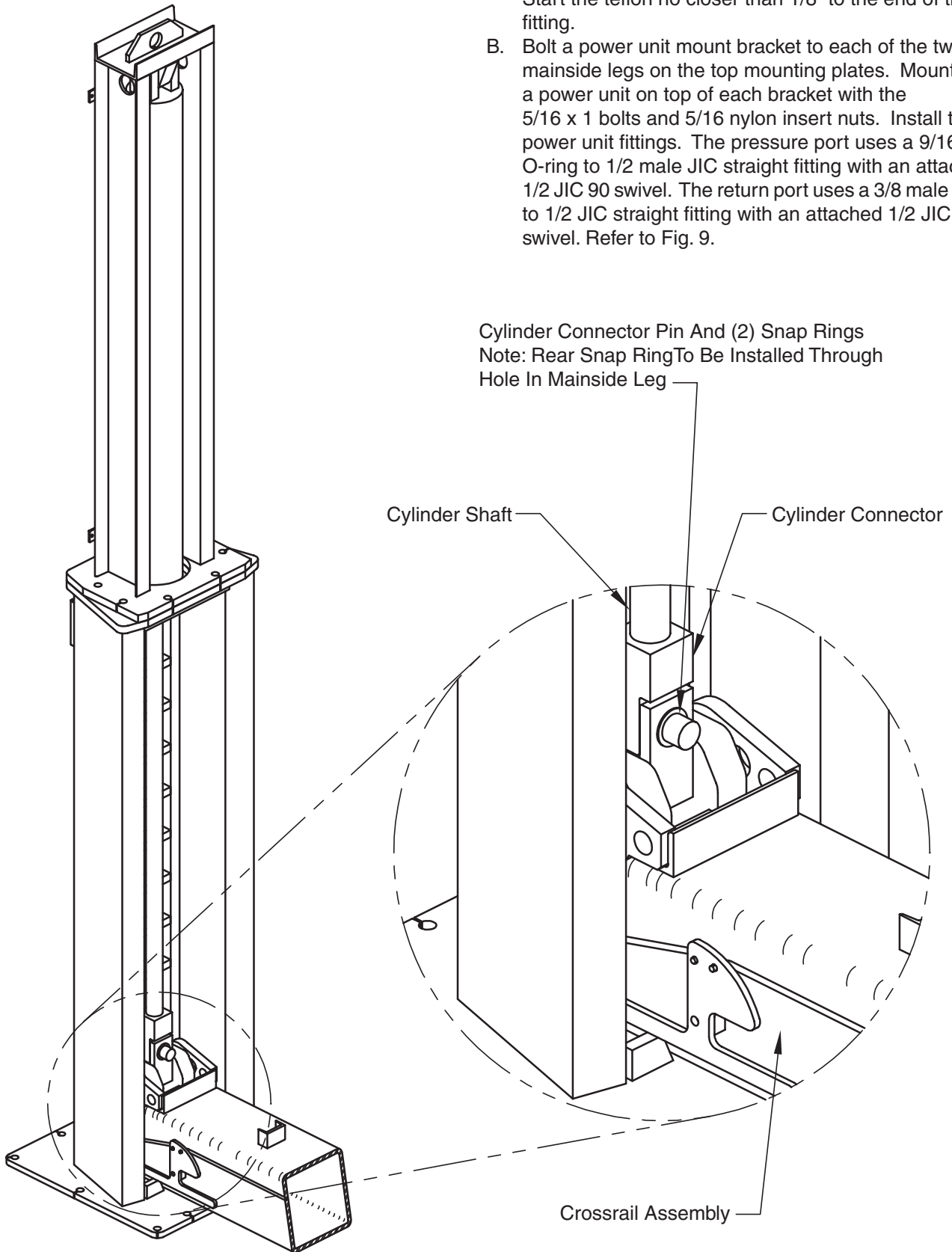

Cylinder Attachment To Cross Rail

Fig. 8

- C. Attach the hoses between the cylinders and the power units. The long hoses attach between the upper cylinder port and the return port on the power unit. The return port is on the same side of the power unit as the electrical enclosure.

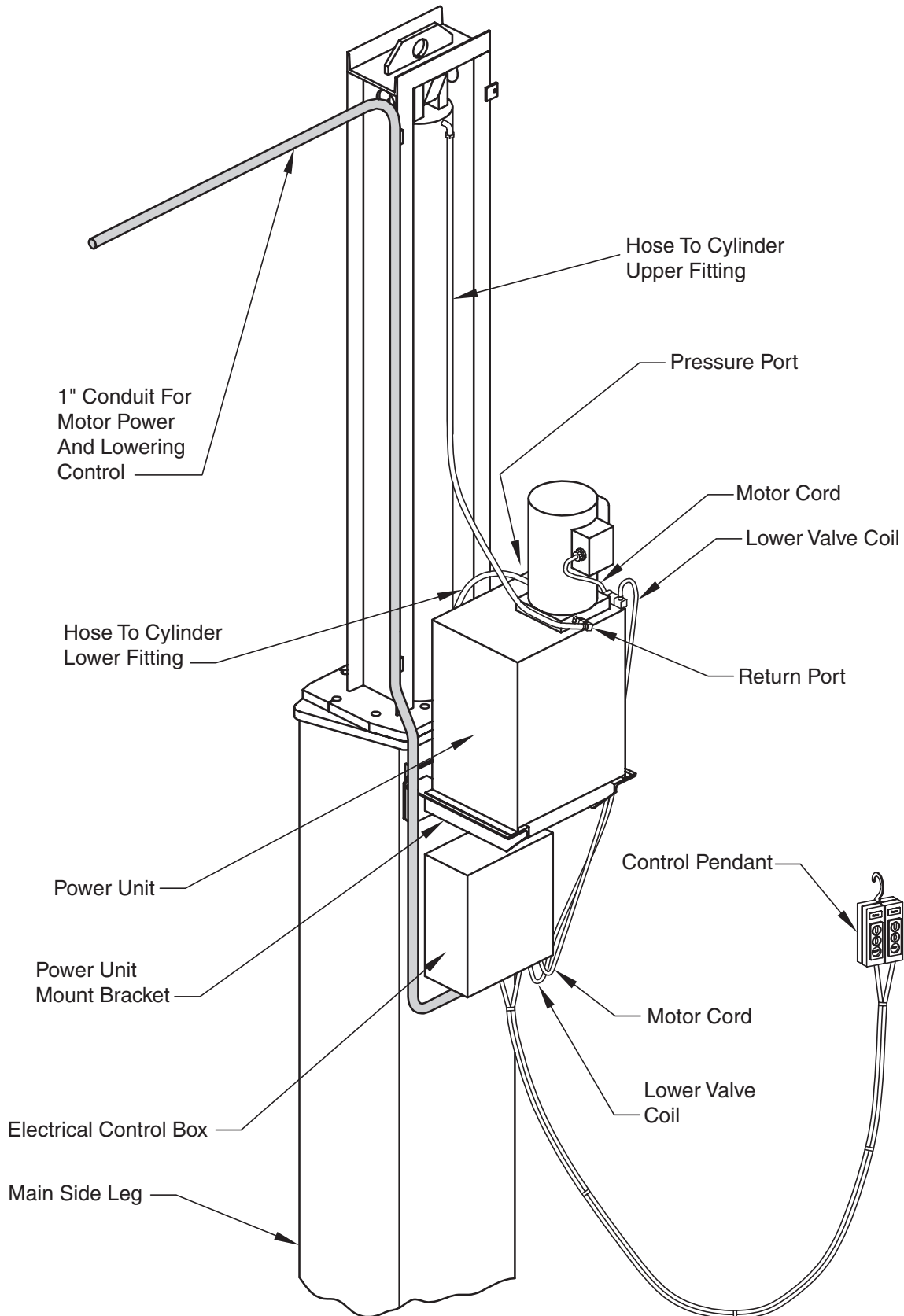

Mainside Leg, Power Unit And Electrical Box Mounting

Fig. 9

6. Electrical: (Refer to Figs. 10 - 10b)

⚠ IMPORTANT This lift is wired and adjusted to operate at 230 volts. If this does not match your facility voltage, Stop; change the transformer jumpers as shown in Fig. 10.

- A. Remove the cover of the electrical control box. If the lift has the mainside legs on the left as shown on the top of Fig. 1, attach the box to the top two holes of the top mounting bracket on the back of the rear mainside leg. If the mainside legs are on the right as shown on the bottom of Figure 1, attach the box on the front mainside leg. Use two 5/16 x 1 bolts with two nylon insert nuts. Refer to Fig. 9. Mount the short cabled lowering valve coil on the post of the lowering valve assembly on the power unit below the control box. Secure with the nut on the post. Mount the long cabled lowering valve coil to the valve assembly on the power unit on the front mainside leg. Replace the cover.
- B. Remove the conduit box covers on the two electric motors. Hook up the short motor lead to the power unit below the control box. The three wires of the motor lead attach to the three single wires in the box using the wire nuts. The terminal on the ground wire of the motor lead is attached to the green ground screw in the motor conduit box. Hook up the long motor lead to the motor on the front power unit in the same way. Replace the covers and tighten the cable clamps.
- C. Hook up the power pigtail to 208/230 volt service. If the lift is equipped with single phase motors, the requirement is 208/230 volt, single phase, 50 amp. If the lift is equipped with three phase motors, the requirement is 208/230 volt, three phase, 30 amp. If 480 volt, three phase, 15 amp.

IMPORTANT It will be necessary to enclose the electrical cables in conduit after the lift is installed. Using tie wraps, the cables can be routed up the legs and across the span between the legs as a temporary installation.

7. Hydraulic / Cylinder Bleeding:

- A. Fill each power unit reservoir with approximately 10 gallons of hydraulic oil. Loosen the hose fitting at the bottom of the rear cylinder. NOTE: When standing on the mainside (power unit) side of the lift, the right top button raises the right end of the lift. The top left button raises the left end of the lift. The two lower buttons lower their respective ends. Briefly run the rear pump until fluid appears at the cylinder fitting. Tighten this fitting and repeat for the front pump and hose.

8. Leveling And Latch Adjustment:

- A. Raise both crossrails about 6". Level the crossrails by adjusting the crossrail chain lengths at the anchor stud nuts at the top of the offside legs. Use a level to check the crossrails. All three chains should have the same tension.
- B. Adjust and plumb the offside legs so that the crossrail chains hang straight (use the level), the crossrails hang in the center of the leg opening, and the legs are plumb.
- C. Raise the lift until the safety latches at each leg have cleared the first welded flat stop in the back of each leg. Lower the lift until the latches just clear the leg latch stops.
- D. The two latches on each crossrail should be the same distance above the stops. If the floor is not level it may be necessary to shim the leg foot of the lower side. After adjusting the height, replumb the leg and check the crossrail for levelness. Adjust the crossrail chain anchor stud nuts on the offside leg if it is necessary to re-level the crossrails. Check and adjust both crossrails as necessary.

IMPORTANT The latches on each crossrail must be within 1/4" of each other in height above the latch stops. This is with respect to the side to side adjustment of the lift.

- E. Raise the lift clear of the stops. Pull down the safety release lever on each crossrail. The lever will lock in down position and the safety latches at each end of the crossrail will lock in the released position.
- F. Lower the lift. The levers and latches should reset when the levers contact the leg bases.

IMPORTANT If the levers and latches do not reset when the lift is lowered to the ground, check and correct the problem.

- G. Raise the lift. Check the alignment of the crossrails and operation of the safety latches as the lift is being raised. The latches should clear the leg stops by approximately 1/2" as the lift moves up and down. At the top of the lift's travel, lower the lift until the safety latches are just above the top stops in the leg. Check and if necessary, adjust the crossrails and legs as described above. Raise the lift to clear the latches, pull the release levers at each crossrail, and lower the lift to the ground.

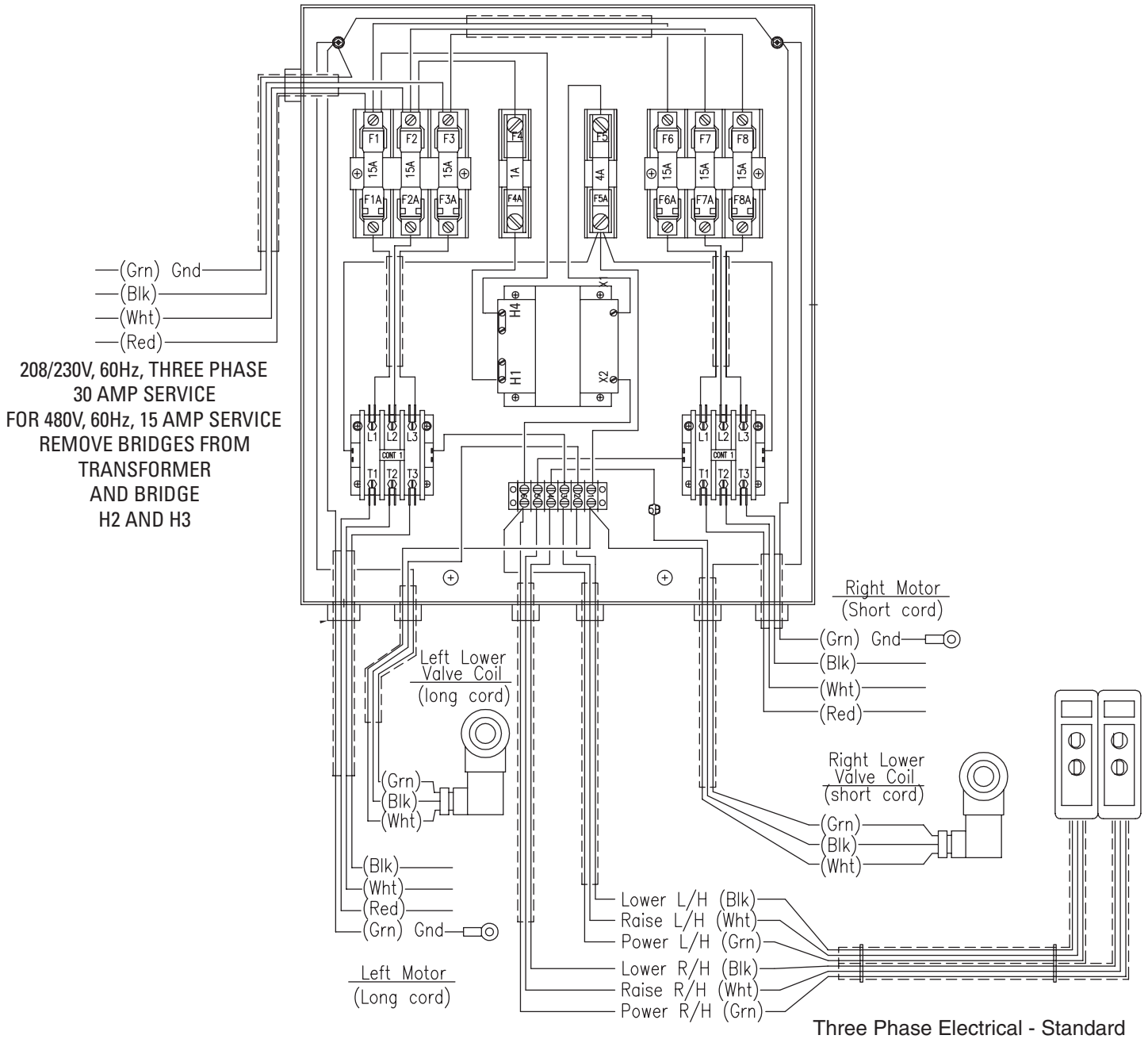
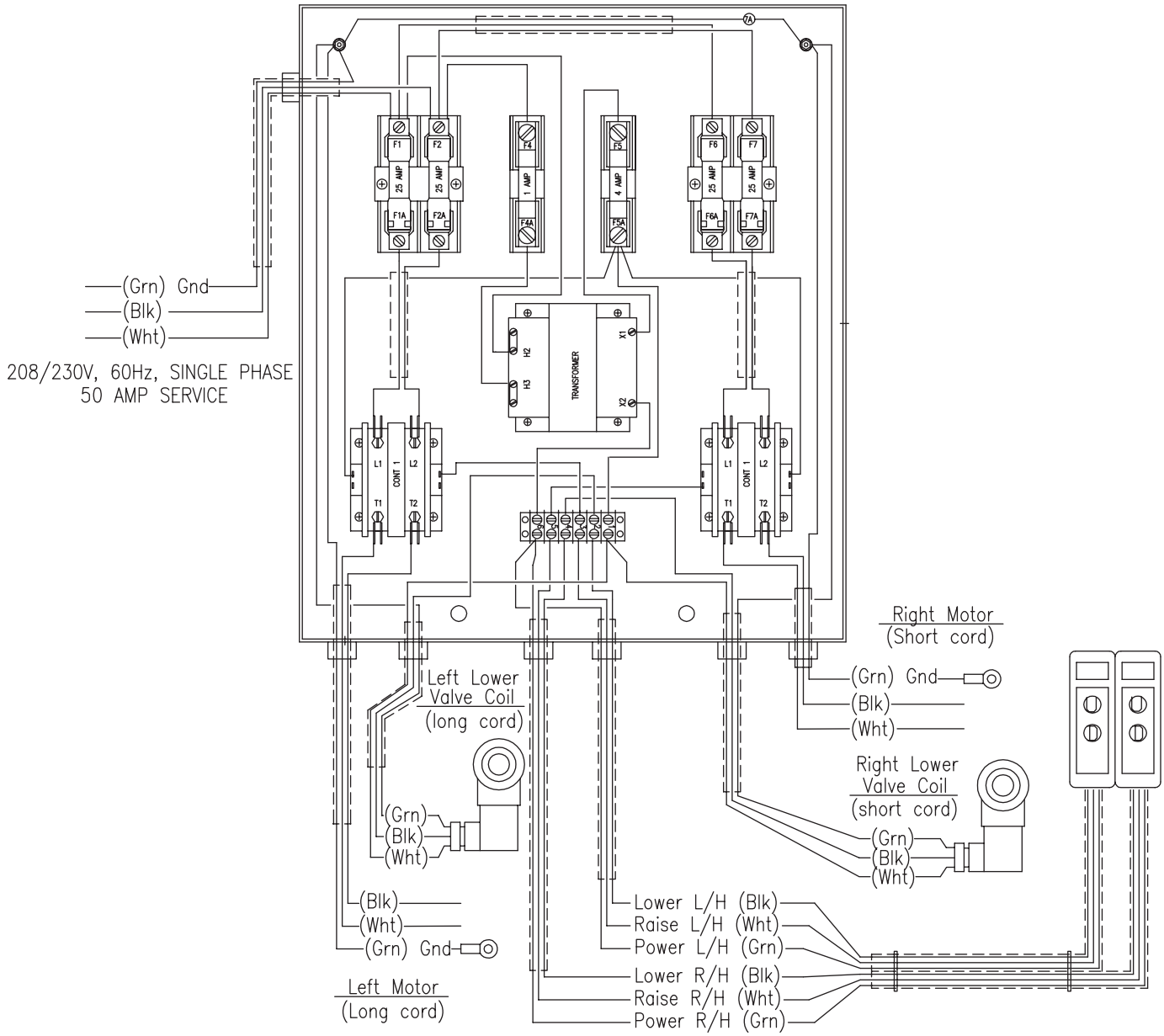

Fig. 10



Single Phase Electrical - Optional

Fig. 10a

1Ø 208/230 VOLT

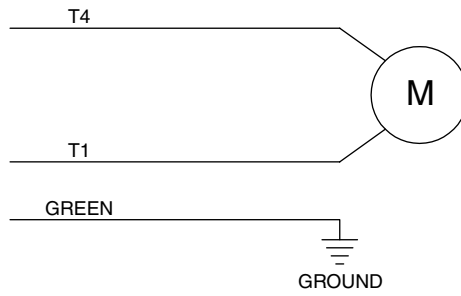

3Ø 208/230 VOLT

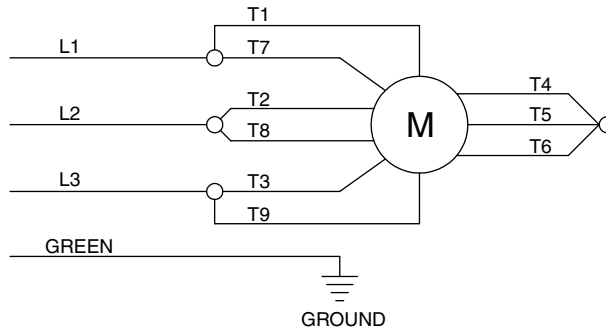

3Ø 460 VOLT

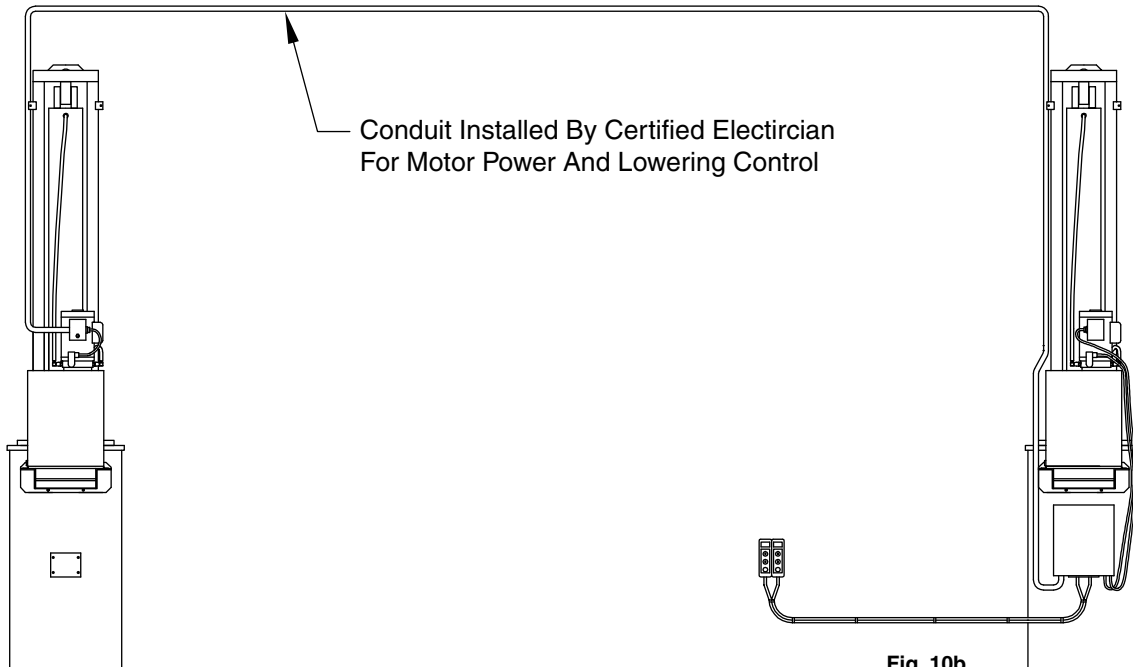
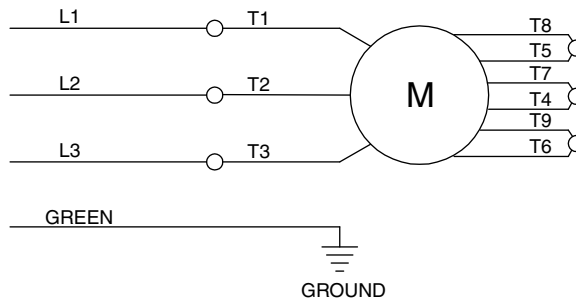

Electric Motor Wiring Diagram

- H. If the alignment and operation of the safety latches is within the required specifications, drill and install the offside leg anchor bolts.
- I. Cycle the lift to its maximum height and back to the ground three times to remove air.

9. Track Stops:

- A. Install the track end stops at the front of the lift. Use two 3/4 x 2 bolts with washers and nuts.
- B. Refer to figure 11, Rear Stop Installation. Thread the weight support rods into the weight approximately 2". Position the weight assembly into the pivot stop at the rear of the lift. Secure the assembly with washers and cotter pins. The hanging length of the weight assembly can be adjusted by threading the rods further in or out.
- C. Position the drive on ramps at the rear of the lift. The ramps should be located one inch away from the track end plate and in line with the tracks. Drill the 1/2" diameter holes in the floor and install the 1/2" diameter x 2-3/4" anchor bolts.

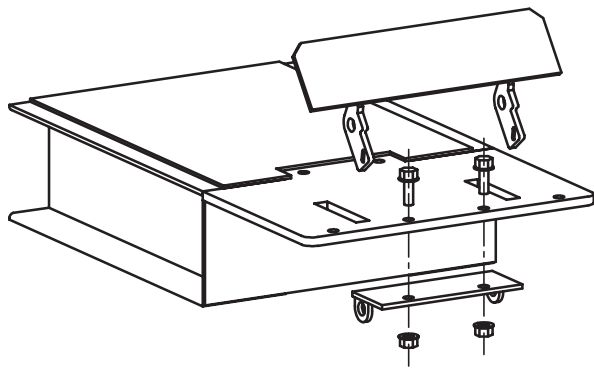

1. Bolt Pivot Plate To Bottom Of Track End Plate
2. Insert Pivot Stop Through Slots In Track End Plate

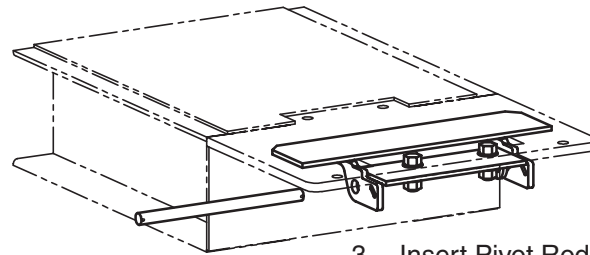

3. Insert Pivot Rod As Shown

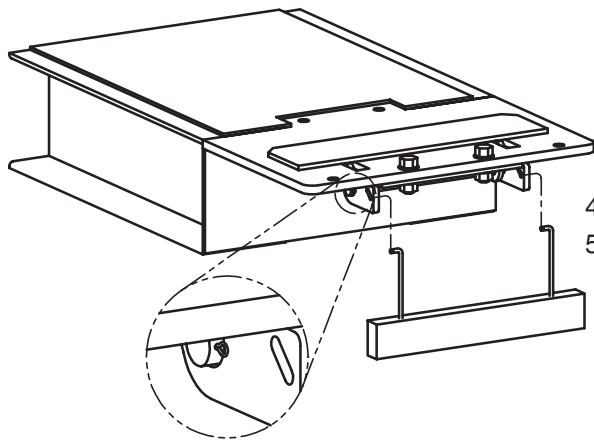

4. Secure The Pivot Rod With Cotter Pins
5. Insert The Weight Assembly As Shown (See Note Below)

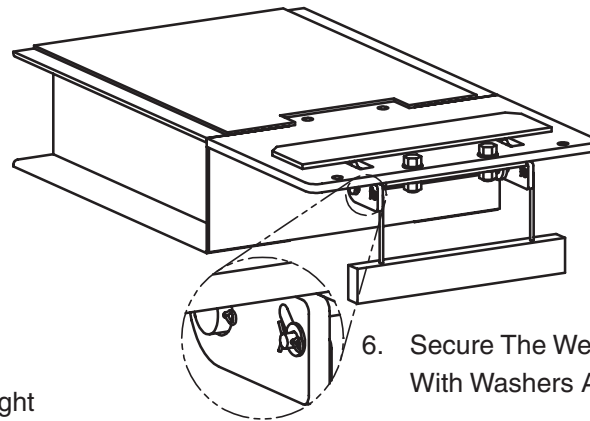

6. Secure The Weight Assembly With Washers And Cotter Pins

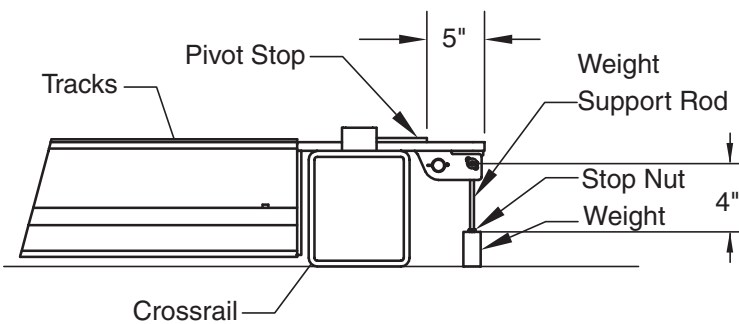

Crossrail / Tracks On Floor

Note:

Thread a nut (5/16"-18NC) onto each suspension rod. Thread the rods approximately 1-1/2" into the weight. Tighten the nuts down against the weight to lock it in place. The weight should have a suspension length such that when it comes into contact with the floor, the pivot stop will rotate down and the "hook" of the suspension rod will move to the approximate center of the slot.

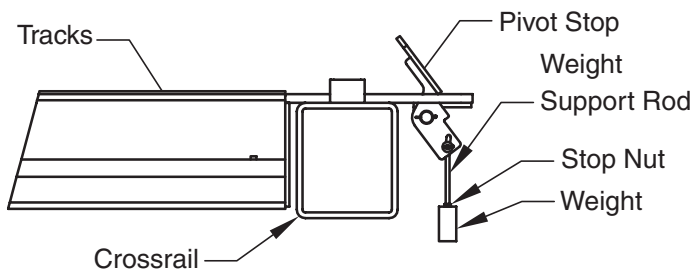

Crossrail / Tracks Elevated

Fig. 11

The Owner/Employer:

- Shall ensure that lift operators are qualified and that they are trained in the safe use and operation of the lift using the manufacturer's operating instructions; ALI/SM07-1, ALI Lifting it Right safety manual; ALI/ST-05 ALI Safety Tips card; ANSI/ALI ALOIM-2008, American National Standard for Automotive Lifts-Safety Requirements for Operation, Inspection and Maintenance; ALI/WL Series, ALI Uniform Warning Label Decals/Placards; and in the case of frame engaging lifts, ALI/LP-GUIDE, Vehicle Lifting Points/Quick Reference Guide for Frame Engaging Lifts.
- Shall establish procedures to periodically inspect the lift in accordance with the lift manufacturer's instructions or ANSI/ALI ALOIM-2008, American National Standard for Automotive Lifts-Safety Requirements for Operation, Inspection and Maintenance; and The Employer Shall ensure that lift inspectors are qualified and that they are adequately trained in the inspection of the lift.
- Shall establish procedures to periodically maintain the lift in accordance with the lift manufacturer's instructions or ANSI/ALI ALOIM-2008, American National Standard for Automotive Lifts-Safety Requirements for Operation, Inspection and Maintenance; and The Employer Shall ensure that lift maintenance personnel are qualified and that they are adequately trained in the maintenance of the lift.
- Shall maintain the periodic inspection and maintenance records recommended by the manufacturer or ANSI/ALI ALOIM-2008, American National Standard for Automotive Lifts-Safety Requirements for Operation, Inspection and Maintenance.
- Shall display the lift manufacturer's operating instructions; ALI/SM 07-1, ALI Lifting it Right safety manual; ALI/ST-05 ALI Safety Tips card; ANSI/ALI ALOIM-2008, American National Standard for Automotive Lifts-Safety Requirements for Operation, Inspection and Maintenance; and in the case of frame engaging lifts, ALI/LP-GUIDE, Vehicle Lifting Points/Quick Reference Guide for Frame Engaging Lifts; in a conspicuous location in the lift area convenient to the operator.
- Shall provide necessary lockout/tagout means for energy sources per ANSI Z244.1- 2003, Safety Requirements for the Lockout/Tagout of Energy Sources, before beginning any lift repairs.
- Shall not modify the lift in any manner without the prior written consent of the manufacturer.

Warning!

Do not raise a vehicle unless the parking brake is set and the wheels are chocked. Stay clear of lift while it is moving. Do not under any circumstances go under the lift unless it is seated on the safety latches in all four legs.

IMPORTANT

Never use this lift to raise just one end of any vehicle. Property damage or personal injury could result.

1. Read this manual thoroughly before operating, or maintaining this lift.
2. Read and refer to often the Safety and Operation Materials supplied with the lift:
3. Following the installation of this lift, this manual and the ALI Safety and Operation Manuals are to be delivered to the owner/user/employer of the lift.
4. Do not raise a vehicle on the lift until the lift has been correctly installed and adjusted as described in this manual.
5. Do not exceed the rated capacity of the lift. The lift is rated at 60,000 lb capacity.
6. For information on positioning vehicles for lifting, refer to the following provided publication: ALI/SM07-1, ALI Lifting it Right safety manual.
7. The troubleshooting and maintenance procedures described in this manual can be done by the lift's owner/employer. Any other procedure should only be done by trained lift service personnel.
8. Replace worn or broken parts only with Genuine Forward Factory Fit Parts.

Important safety instructions

1. Read all instructions.
2. Care must be taken as burns can occur from touching hot parts.
3. To reduce the risk of fire, do not operate equipment in the vicinity of open containers of flammable liquids (gasoline).
4. Adequate ventilation should be provided when working on internal combustion engines.
5. Keep hair, loose clothing, fingers, and all parts of body away from moving parts.
6. To reduce the risk of electric shock, do not use on wet surfaces or expose to rain.
7. Use only as described in this manual, use only manufacturer's recommended attachments.
8. Always wear safety glasses. Everyday eyeglasses only have impact resistant lenses, they are not safety glasses.

OPERATING INSTRUCTIONS

WARNING!

STAY CLEAR OF LIFT WHILE IT IS MOVING. DO NOT UNDER ANY CIRCUMSTANCES GO UNDER THE LIFT UNLESS IT IS SEATED ON THE SAFETY LATCHES IN ALL FOUR LEGS.

Raising Vehicles:

1. Drive vehicle onto lift. Set parking brake and chock wheels.
2. Hold the control pendant and move to a position between the mainside legs so that both ends of the lift can be observed. The left top button raises the left end of the lift. The right top button raises the right end of the lift. Press both buttons to raise the lift. The heavy end of the lift will typically move up slower than the light end. It will be necessary to periodically release the button controlling the one end of the lift that is ahead and allow the other end to catch up and keep the lift level. Do not allow the lift to become more than 6 to 8 inches out of level. This is approximately one safety latch position.
3. Once the lift has cleared the four latch positions at the level that it is desired to stop, release the pressure on the two raise buttons. Lower both ends onto the latch stops using the two down buttons.

BEFORE WALKING UNDER THE LIFT, VERIFY THAT THE FRONT AND REAR CROSSRAILS ARE RESTING SECURELY ON THE SAFETY LATCHES.

Lowering Vehicles:

1. Raise the tracks off of the safety latches using the two push buttons on the control pendant.
2. Release the latches by pulling down the release levers on both the front and rear crossrails. The levers will lock in the down position.

IMPORTANT

DO NOT WORK OR WALK UNDER THE LIFT WHEN THE SAFETY LATCHES ARE IN THE RELEASE POSITION. IF IT IS NECESSARY TO RETURN UNDER THE LIFT, MANUALLY RESET THE LEVERS BY PUSHING THE CROSSRAIL RELEASE LEVERS TO THE UP POSITION.

3. Move to a position where both ends of the lift can be observed. Push both lower buttons to lower the lift. Typically, the heavy end of the lift will come down faster. Release the button controlling the low end to allow the other end to catch up to return the lift to a level condition. Once the lift is approximately level, press both buttons to continue. Do not allow the lift to get more than 6 to 8" out of level.

IMPORTANT

THE SAFETY LATCHES WILL AUTOMATICALLY RESET WHEN THE LIFT REACHES THE GROUND. IF THE LIFT IS RAISED AGAIN BEFORE THE LIFT IS COMPLETELY LOWERED TO THE GROUND, THE SAFETY LATCHES WILL NOT AUTOMATICALLY RESET. THE LATCHES MUST BE MANUALLY RESET BY PUSHING THE CROSSRAIL RELEASE LEVERS TO THE UP POSITION.

MAINTENANCE

1. WEEKLY: Check operation of the safety latch mechanism. Correct alignment of legs and crossrails as required. Correct linkage problems as required.
2. MONTHLY: Lubricate lifting and cross rail chains with a quality chain lubricant.
3. Use only petroleum based hydraulic oil, approximately ISO 32, such as Mobil DTE 24 or Texaco HD 32.

TROUBLE SHOOTING INSTRUCTIONS

1. Motor does not run when push button switch activated.
 - a. Unit is not plugged in or power switch is off.
 - b. Breaker is thrown or overload is tripped.
 - c. Push button switch is bad, call the dealer.

2. Motor runs but lift will not raise or raises partially.
 - a. Not enough oil in reservoir.
 - b. Foreign matter in valving. Remove valve and coil from pump. Activate valve with coil and clean with compressed air. Replace and retry. If not successful, valve may be faulty.

3. Motor runs but lift will not pick up heavy load.
 - a. Lift is overloaded. The lift is rated to raise 60,000 pounds. The relief valve setting will not allow overloading.
 - b. Relief valve in the power unit not set correctly. The relief valve is preset at the factory and cannot be adjusted. Call the dealer.
 - c. Piston seal of cylinder is damaged. Look for oil at the breather in the return line to the power unit when the lift is fully raised.

4. Oil blows out of the breather cap.
 - a. Oil reservoir is overfilled.

5. Lift will not lower or will not lower evenly.
 - a. Safety latch at one or more legs is not moving to the full release position when the latch release levers are pulled. Check the operation and alignment of the latches and release linkages on the crossrails. Check the alignment and plumbness of the legs and the adjustment of the latches.

6. Safety latches do not reset when the lift is lowered completely to the ground.
 - a. Check the operation and alignment of the linkages on the crossrails.

LIFT LOCKOUT/TAGOUT PROCEDURE

Purpose

This procedure establishes the minimum requirements for the lockout of energy that could cause injury to personnel by the operation of lifts in need of repair or being serviced. All employees shall comply with this procedure.

Responsibility

The responsibility for assuring that this procedure is followed is binding upon all employees and service personnel from outside service companies (i.e., authorized installers, contactors, etc.). All employees shall be instructed in the safety significance of the lockout procedure by the facility owner/manager. Each new or transferred employee along with visiting outside service personnel shall be instructed by the owner/manager (or assigned designee) in the purpose and use of the lockout procedure.

Preparation

Employees authorized to perform lockout shall ensure that the appropriate energy isolating device (i.e., circuit breaker, fuse, disconnect, etc.) is identified for the lift being locked out. Other such devices for other equipment may be located in close proximity of the appropriate energy isolating device. If the identity of the device is in question, see the shop supervisor for resolution. Assure that proper authorization is received prior to performing the lockout procedure.

Sequence of Lockout Procedure

- 1) Notify all affected employees that a lockout is being performed and the reason for it.
- 2) Unload the subject lift. Shut it down and assure the disconnect switch is "OFF" if one is provided on the lift.
- 3) The authorized lockout person operates the main energy isolation device removing power to the subject lift.
 - If this is a lockable device, the authorized lockout person places the assigned padlock on the device to prevent its unintentional reactivation. An appropriate tag is applied stating the person's name, at least 3" x 6" in size, an easily noticeable color, and states not to operate device or remove tag.
 - If this device is a non-lockable circuit breaker or fuse, replace with a "dummy" device and tag it appropriately as mentioned above.
- 4) Attempt to operate lift to assure the lockout is working. Be sure to return any switches to the "OFF" position.
- 5) The equipment is now locked out and ready for the required maintenance or service.

Restoring Equipment to Service

- 1) Assure the work on the lift is complete and the area is clear of tools, vehicles, and personnel.
- 2) At this point, the authorized person can remove the lock (or dummy circuit breaker or fuse) & tag and activate the energy isolating device so that the lift may again be placed into operation.

Rules for Using Lockout Procedure

Use the Lockout Procedure whenever the lift is being repaired or serviced, waiting for repair when current operation could cause possible injury to personnel, or for any other situation when unintentional operation could injure personnel. No attempt shall be made to operate the lift when the energy isolating device is locked out.

OPERATING CONDITIONS

Lift is not intended for outdoor use and has an operating ambient temperature range of 41°-104°F (5°-40°C).

Vehicle Service GroupSM

2700 Lanier Drive
Madison, IN 47250, USA
1-800-640-5438
www.vsgdover.com



© Vehicle Service GroupSM

All Rights Reserved. Unless otherwise indicated, **Vehicle Service GroupSM** and all other trademarks are property of Dover Corporation and its affiliates.