

# FOUR-POST LIFT

14,000 lbs. Capacity  
(4000 Series Lifts)

Note: At the rated capacity of 14,000 lbs. lift was designed for:  
101" Minimum wheelbase for models without rolling jacks  
124" Minimum wheelbase for models with rolling jacks  
152 1/2" Minimum wheelbase for models with extensions

## Installation and Owner's Manual

**ATTENTION!**  
**Read all manuals**  
**thoroughly before**  
**installing, operating,**  
**or maintaining the lift.**

# Table of Contents

Chapter/Paragraph	Page
1 Safety Summary	3
1.1 General Safety Instructions	3
1.2 Warnings, Cautions, and Notes	3
2 Installation and Preparation for Use	4
2.1 General Information	4
2.2 Tools and Equipment Required	4
2.3 Foundation Requirements	4
2.4 Installation	5
2.4.1 Plan Installation Layout	5
2.4.2 Runways and Crossbeams	6
2.4.3 Install Runways to Crossbeams	9
2.4.4 Cable Installation	9
2.4.5 Mount Control Post	10
2.4.6 Installation of Power Unit and Hydraulic Lines	12
2.4.7 Air Valve and Air Tubing Installation	13
2.4.8 Installation of Remaining Columns	14
2.4.9 Leveling Lift	17
2.4.10 Installation of Tire Stoppers and Approach Ramps	18
3 Operating Instructions	19
3.1 Safety Procedures	19
3.2 Daily Pre-Operation Check (8-Hours)	21
3.3 Controls	21
3.4 Operation	21
3.4.1 Basic Lift Operation	23
3.4.2 Optional Wheel Alignment Kit Operation	23
4 Maintenance and Troubleshooting	24
4.1 Maintenance	24
4.1.1 Owner/Employer Responsibilities	24
4.1.2 Periodic Maintenance Schedule	24
4.1.2.1 Daily Pre-Operation Check (8-Hours)	24
4.1.2.2 Weekly Maintenance (every 40-Hours)	24
4.1.2.3 Yearly Maintenance	24
4.1.2.4 Special Maintenance Tasks	25
4.2 Troubleshooting	25
4.2.1 Motor Does Not Operate	25
4.2.2 Motor Functions But Lift Will Not Rise	25
4.2.3 Oil Blows out Breather of Power Unit	26
4.2.4 Motor Hums and Will Not Run	26
4.2.5 Lift Jerks Going Up and Down	26
4.2.6 Oil Leaks	27
4.2.7 Lift Makes Excessive Noise	27
5 Additional Inspection and Maintenance Procedures	27
5.1 Daily Inspection & Maintenance	27
5.2 Monthly Inspection & Maintenance	29
5.3 Quarterly Inspection & Maintenance	29
5.4 Cable Adjustment	32
6 Lift Lockout/Tagout Procedure	33
7 Operating Conditions	34
8 Illustrated Parts Breakdown	35

# 1. Safety Summary

## 1.1 General Safety Instructions

This summary describes physical and chemical processes that may cause injury or death to personnel, or damage to equipment if not properly followed. This safety summary includes general safety precautions and instructions that must be understood and applied during operation and maintenance to ensure personnel safety and protection of equipment. Prior to performing any task, the WARNINGS, CAUTIONS, and NOTES included in that task should be reviewed and understood.

## 1.2 Warnings, Cautions, and Notes

WARNINGS and CAUTIONS are used in this manual to highlight operating or maintenance procedures, practices, conditions or statements that are considered essential to protection of personnel (WARNING) or equipment (CAUTION). WARNINGS or CAUTIONS immediately precede the step or procedure to which they apply. NOTES are used in this manual to highlight operating or maintenance procedures, practices, conditions or statements that are not essential to the safeguarding of personnel or equipment. NOTES may precede or follow the step or procedure, depending on the information to be highlighted. The Headings used and their definitions are as follows.

### **WARNING!**

Highlights essential operating or maintenance procedure, practice, condition, statement, etc. that if not strictly observed, could result in injury to, or death of, personnel or long term health hazards.

### **CAUTION!**

Highlights essential operating or maintenance procedure, practice, condition, statement, etc. that if not strictly observed, could result in damage to, or destruction of equipment.

### **NOTE**

Highlights essential operating or maintenance procedure, practice, condition, or statement.

## 2. Installation and Preparation for Use

### 2.1 General Information

- 1 Any freight damage must be noted on the freight bill before signing and reported to the freight carrier with a freight claim established. Identify the components and check for shortages. If shortages are discovered, contact your service company immediately. Refer to section 8 for the parts information.
- 2 Consult building owner and / or architect's plans when applicable to establish the best lift location, which must be indoors and protected from the elements. Lift is intended for indoor use only.

#### **WARNING!**

DO NOT install on asphalt or other similar unstable surface. Columns are supported only by anchors in floor.

#### **NOTE**

Check for ceiling clearance first to see how high the lift can be set up in your bay.

#### **NOTE**

Lift intended for indoor use only.

### 2.2 Tools and Equipment Required

The installation of this lift is relatively simple and can be accomplished by two men in a few hours. The following tools and equipment are needed:

- Concrete Rotary Hammer drill with ¾" carbide bit. Core Drill Rebar Cutter recommended
- 12" Crescent Wrench
- Open Wrench set
- Phillips and flat head screwdrivers
- Hammer
- Retainer Ring Pliers
- Electrical Pliers
- Level
- 25' Tape Measure
- Step Ladder
- Gallons of hydraulic oil, SAE-10 or equivalent

### 2.3 Foundation Requirements

The foundation requirements are listed below:

#### **WARNING!**

***Columns are supported only by anchoring in the floor. DO NOT install on asphalt or other similar unstable surface Failure to follow the requirements of the following step could result in damage to, or destruction of equipment.***

The foundation has to be long enough for the vehicles to be supported, wide enough to provide support for the lift, and the concrete shall have compression strength of at least 3,000 PSI and a minimum thickness of 4" in order to achieve a minimum anchor embedment of 3-1/4" when using the standard supplied 3/4" x 5-1/2" long anchors. If the top of the anchor exceeds 2-1/4" above the floor grade you DO NOT have enough embedment. Allow a minimum of 6" from the column base plate to any foundation edge.

## 2.4 Installation

Install as given in the following paragraphs.

### 2.4.1 Plan Installation Layout

The lift requires the space as shown in figure 2-2. The major components of the lift are shown in figure 2-3 for familiarity. Select the spot on your foundation where the Front Left Control Post is to be located and plan from there.

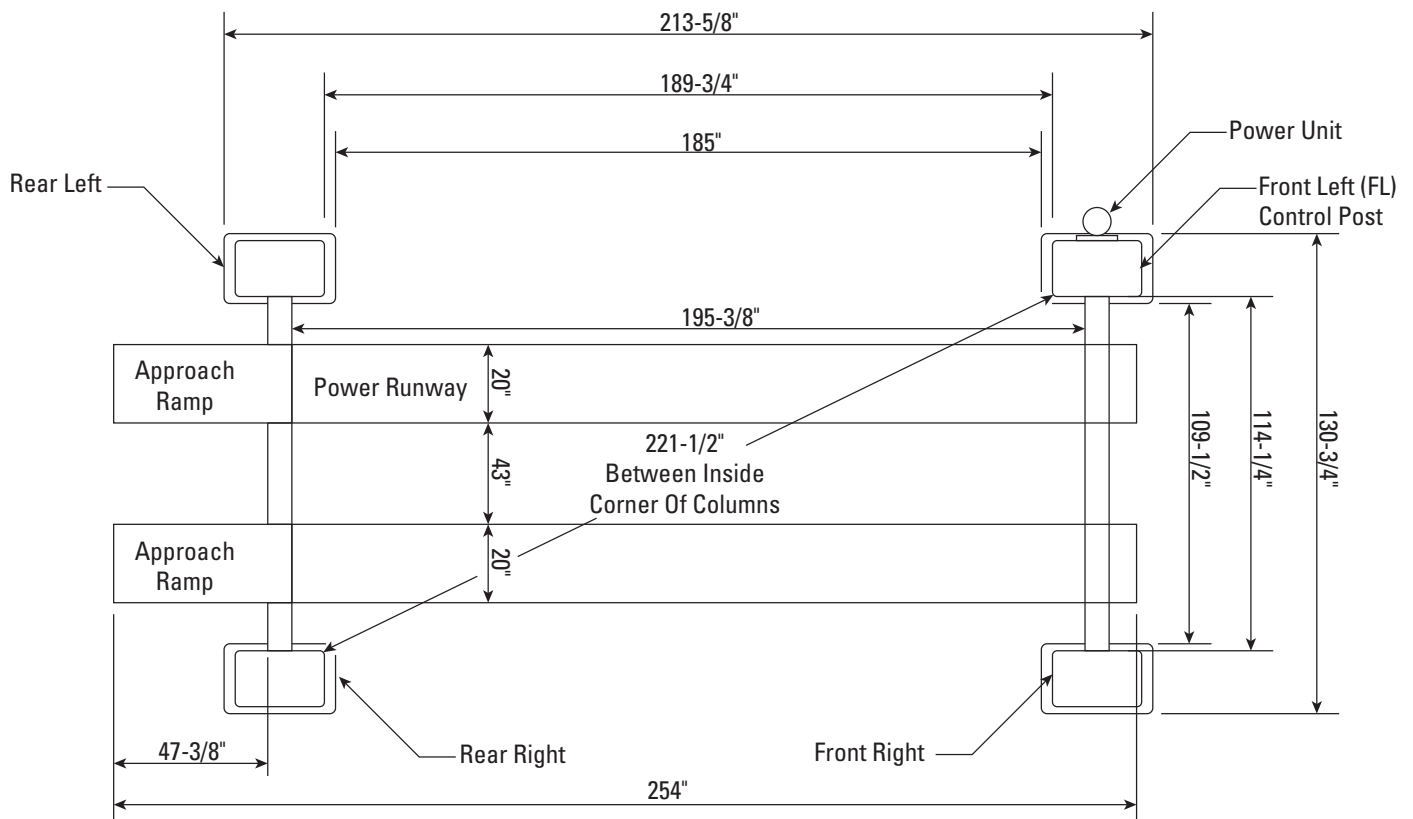

**Figure 2-2. Setup Dimensions**

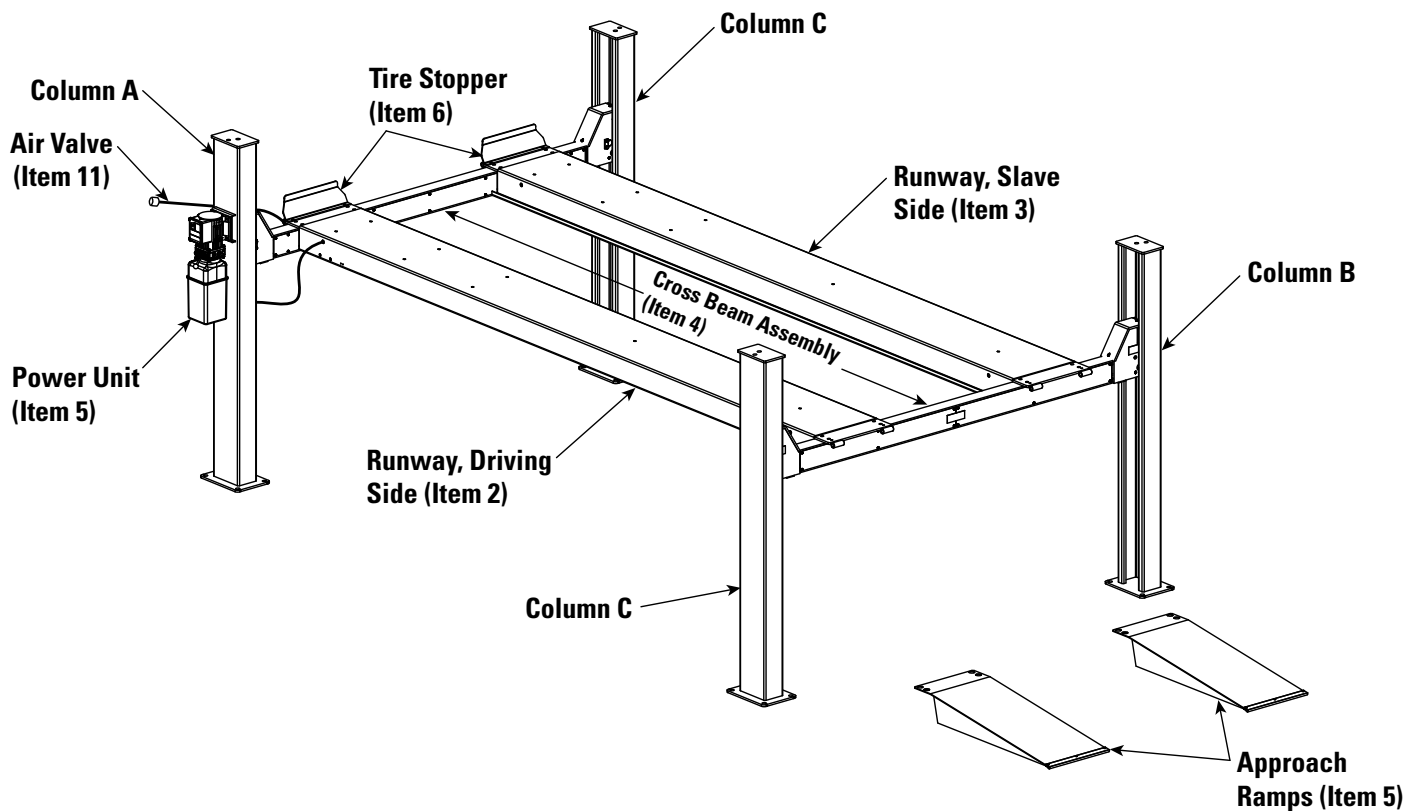

**Figure 2-3. Major Components**

## 2.4.2 Runways and Crossbeams

Assemble the runways and crossbeams as given in the following steps:

1. Unpack the lift by remove all wrapping film.
2. While runway is upside down, remove all plastic ties securing cables. Extend cable ends through runway ends. Remove cylinder rod shipping block. Tighten all hydraulic fittings.
3. Place runways in predetermined location. The control post (Column A – figure 2-3) and power unit will be located on the front left as shown on figure 2-2. The power runway (Runway, Drivers Side (item 2 in parts list) will also be on the left side. The control post is located in the front left corner. At this time, there are no other configurations available for this lift.

**NOTE**

Elevate runways off floor with blocks of wood to prevent any damage.

4. Place front and rear crossbeams on each ends of the runways. The runways and crossbeams should be laid out as shown in figure 2-4. Do not attach at this time.

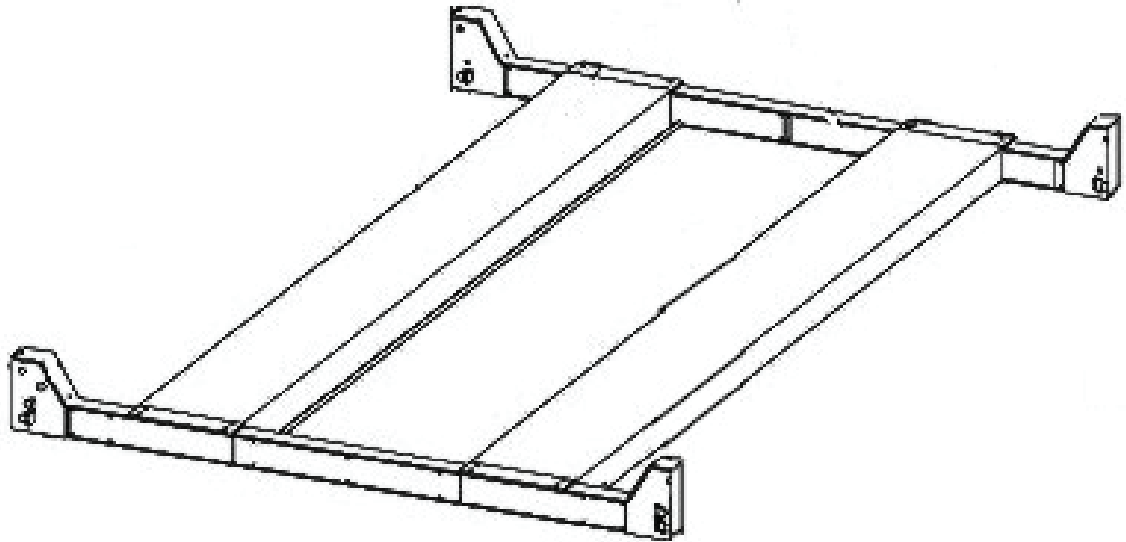

**Figure 2-4. Positioning of Runways and Crossbeams**

**NOTE**

Air supply line "T" fittings need to be closest to power side of lift.

5. Install the cables listed below through crossbeams. It is easier to slide cable thru crossbeam with covers on. See figure 2-5 for cable routing diagram.

**NOTE**

There are four total cables, each are a different length. Follow the diagram for cable routing carefully.

Item	Drawing Number	Description
60	H4P-5002-2	1/2" Cable A 219"
61	H4P-5002-1	1/2" Cable B 156"
62	H4P-5002-4	1/2" Cable C 422-1/2"
63	H4P-5002-3	1/2" Cable D 360"

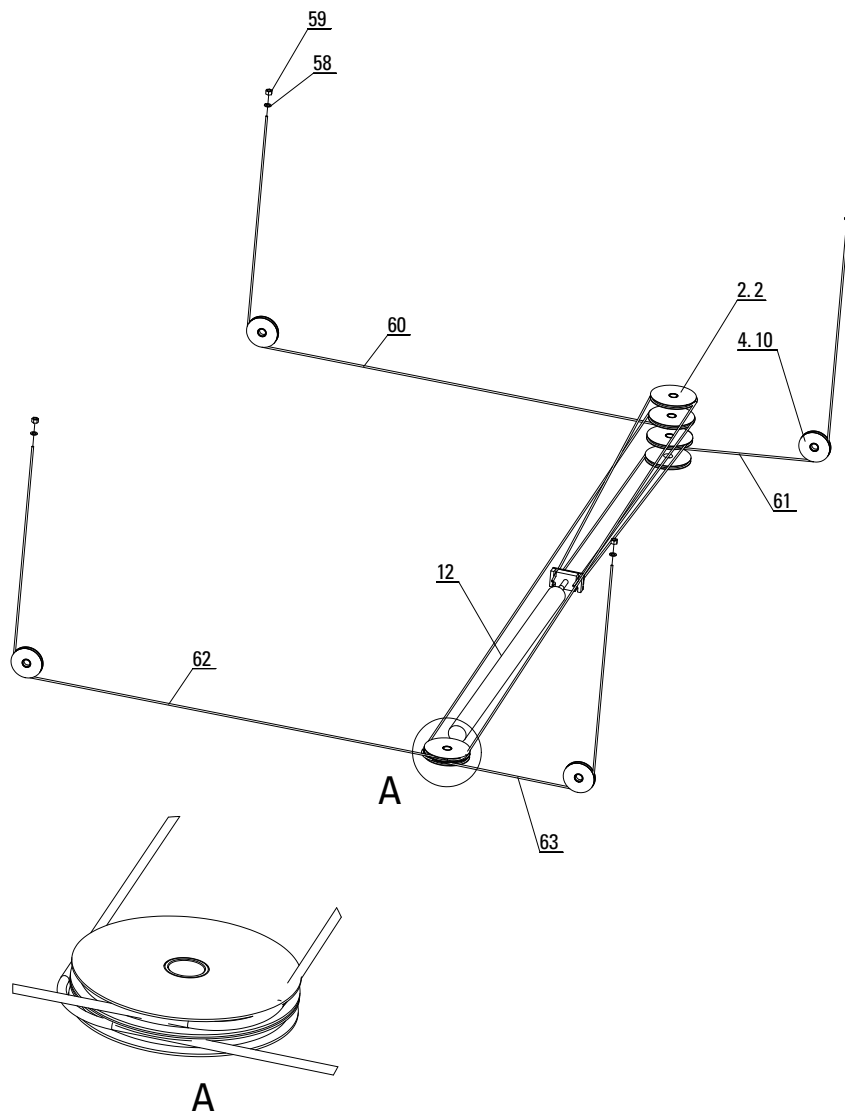

**Figure 2-5. Cable Routing Details**

6. Remove all covers on crossbeams and retain hardware. They will be reinstalled later in the installation.



### 2.4.3 Install Runways to Crossbeams

Install the runways to the crossbeams using the hardware from the parts list as listed below. Make sure the cables are on correct sheave in runway. Refer to figure 2-6.

Item	Drawing Number	Description
2	H4P-3000	Runway
4	H4P-1100G	Crossbeam
17	B17-16 x 50	M16 x 50 Bolts (12.9 grade)
18	B40-16	Ø 16 Lock Washer
19	B41-16	Ø 16 Flat Washer
20	B31-16	M16 Nuts

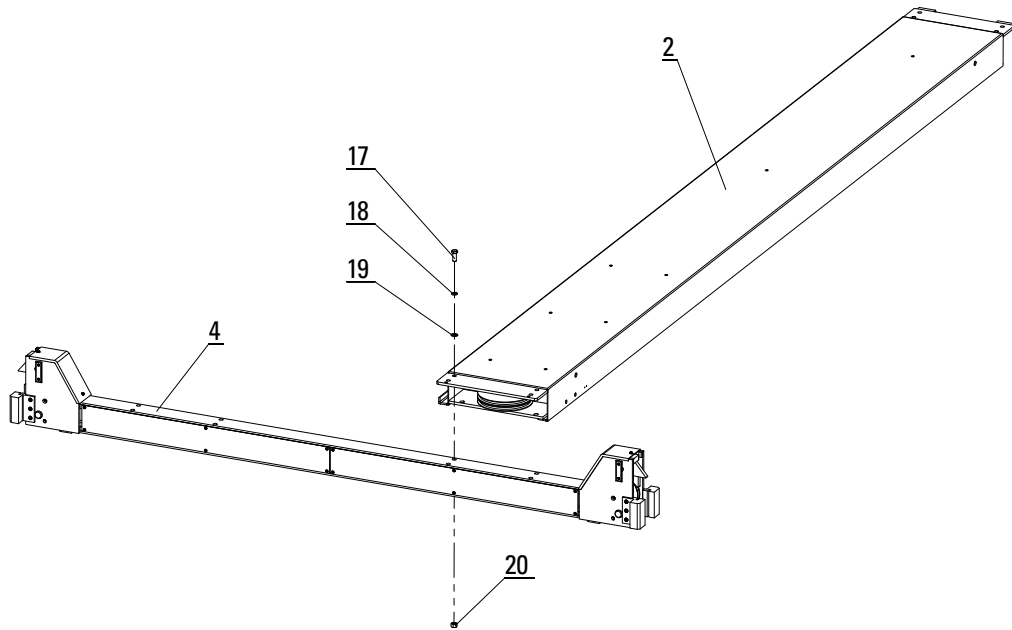

**Figure 2-6. Runways-to-Crossbeams Assembly**

### 2.4.4 Cable Installation

Install cables through crossbeams as follows. Refer to figure 2-7:

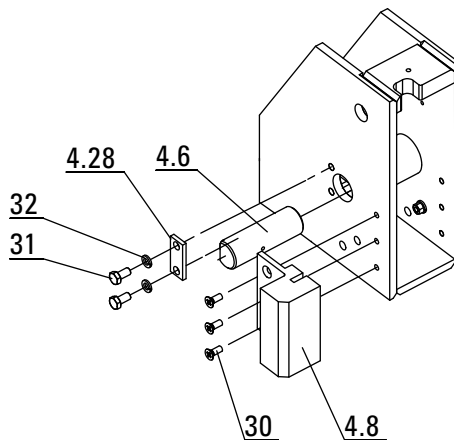

**Figure 2-7. Cable Installation through Crossbeams**

1. Remove two M10×20 Bolts (item 31), Ø10 Lock Washers (item 32), and Shaft Locker (item 4.28).
2. Remove cable security shaft (item 4.6) from the crossbeam end to allow installation of cable.
3. Install cable over sheave and reinstall security shaft (item 4.6). Secure with the two M10×20 Bolts (item 31), Ø 10 Lock Washers (item 32), and Shaft Locker (item 4.28) removed in step 1. Repeat at all remaining crossbeam ends.

### 2.4.5 Mount Control Post

First install Cross Beam Positioning Blocks (item 4.8 as shown in figure 2-7) on crossbeams with M8×25 Screws (item 13 in parts listing). Only install one guide on each side of the crossbeam or you will NOT be able to fit inside the column.

#### **WARNING!**

Failure to position the column as directed in the following step could result in foundation damage that can cause death or serious injury as well as damage to the equipment. Columns are supported only by anchoring in the floor. DO NOT install on asphalt or other similar unstable surface. Accurate dimensions are extremely important. Allow a minimum of 6" from the column base plate to any foundation edge.

1. Mount the control post in the position determined in paragraph 2.4.1 (Plan Installation Layout). Move column towards yoke until the slider is barely inside the column. Install slider on opposite side at this time, see figure 2-7.
2. Slide ladder bar down behind yoke inside column. ENSURE that ladder bar slides through grooves in Cross Beam Position Blocks. Note orientation fig. 2-7-1 with the slot being at the bottom of the ladder bar. Make sure the control post is plumb. Use shims provided in hardware kit if needed. **Ensure column is pushed flush against cross beams when level. This is critical.**

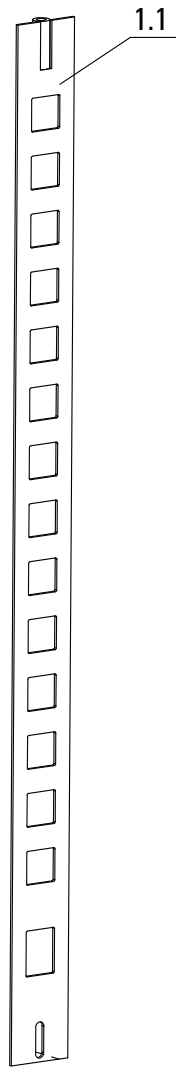

**Fig. 2-7-1**

Refer to Fig. 2-7-2. Note assembly is exploded for clarity. Ladder bar must already be installed inside column. Assemble M20 Nut (36) to Adjustment Rod (1.2). Insert through top of column being sure to use hole nearest the outside of the column. Install second M20 Nut. Thread Adjustment Rod into Ladder Bar (1.1). Note, the thread should stop flush with bottom of threaded pipe welded to ladder bar. It is possible to thread adjustment bar down too far. This will not allow for proper adjustment of ladder bar because of the lack of remaining threads.

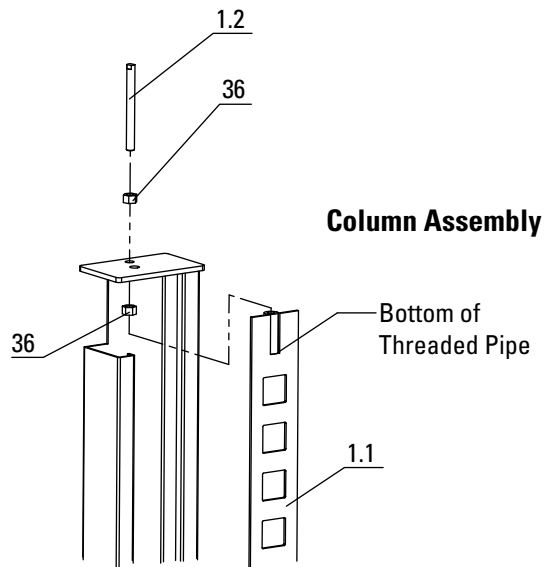
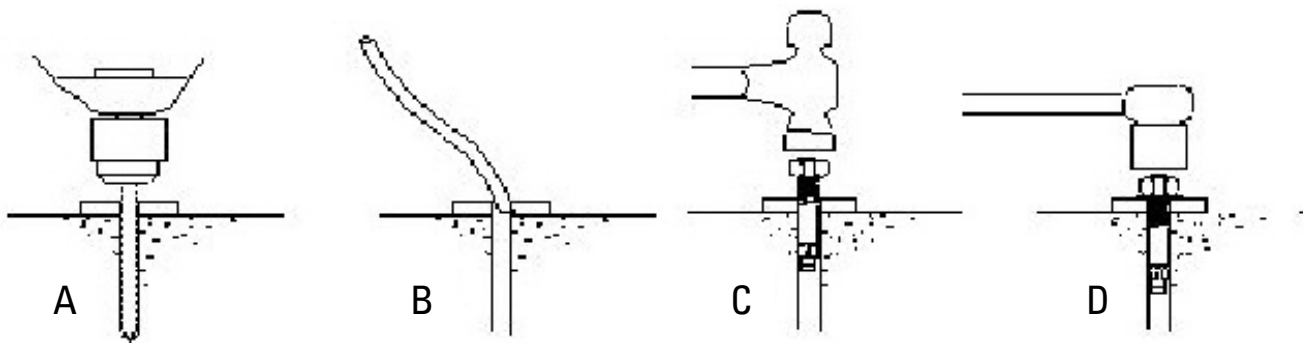

**Fig. 2-7-2**

2. Secure the column to the foundation as follows (refer to figure 2-4):

a) Using a 3/4" diameter concrete drill, drill the anchor holes in the concrete for the main side column, installing anchors as you go. Use a concrete hammer drill with a carbide tip solid drill bit the same diameter as the anchor, 3/4". (.775 to .787 inches diameter). Do not use excessively worn bits or bits which have been incorrectly sharpened. Refer to figure 2-8 Detail A. Use the following guide while drilling the anchor holes in the concrete:

- 1) Keep the drill in a perpendicular line while drilling.
- 2) Use a block of wood or rubber mallet to drive anchor bolts into the concrete.
- 3) Drill to a minimum depth of 4 in. to make sure maximum holding power is achieved. Drilling thru concrete (recommended) will allow the anchor to be driven thru the bottom if the threads are damaged.
- 4) Let the drill do the work. Do not apply excessive pressure. Lift the drill up and down occasionally to remove residue to reduce binding.
- 5) Drill the hole to depth equal to the length of anchor.
- 6) For better holding power blow dust from the hole (Refer to figure 2-8 Detail B).



**Figure 2-8. Anchor Hole Drilling and Seating**

3. Place a flat washer and hex nut over threaded end of anchor, leaving approximately 1/2 inch of thread exposed and carefully tap anchor (Refer to figure 2-8 Detail C). Do not damage threads.

4. Tap anchor into the concrete until nut and flat washer are against base plate. Do not use an impact wrench to tighten (Refer to figure 2-8 Detail D).

**NOTE**

Do not tighten the post at this time.

5. Make sure the control post is plumb. Use shims provided in hardware kit if needed. Once post is level, tighten the four anchor bolts to 65-85 ft-lbs of torque each.

## 2.4.6 Installation of Power Unit and Hydraulic Lines

Install the power unit and hydraulic lines by doing the following:

1. Install the power unit as shown in figure 2-9 using the following parts from the parts list:

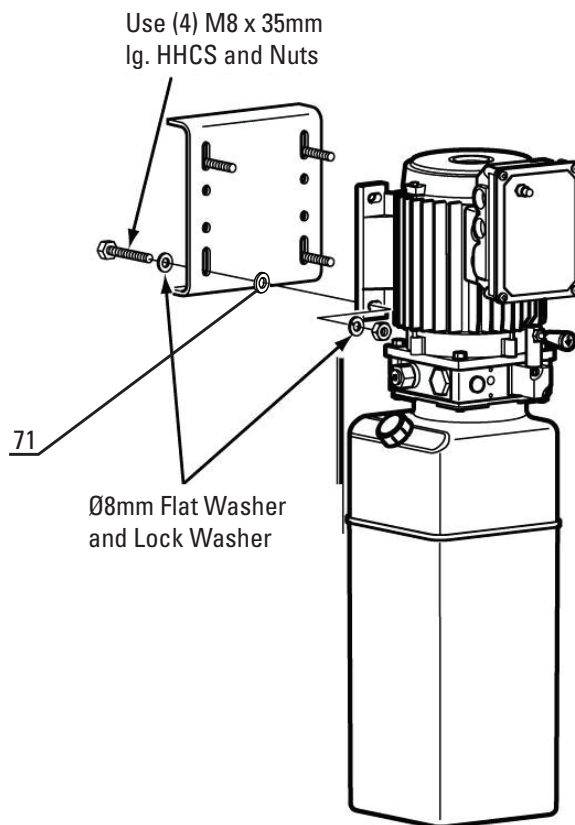

**Figure 2-9. Power Unit Installation**

2. Install the hydraulic lines using the following parts from the parts listing. Refer to figure 2-10. The power unit hydraulic pump has a plastic cap protecting the hose fitting. Remove and discard the cap

Item	Drawing Number	Description
11	TSV86522S	Air Valve
12	YG18-9100G2	Hydraulic Cylinder (Reference)
31	B10-10x20	M10x20 Bolt
32	B40-10	Ø10 Lock Washer
33	B85-6	M6 Oil Zerk
52	B41-10	Ø10 Flat Washer
53	H4D-Y003	Fitting, Elbow
55	SW-002 (30400-9053YZ)	Fitting, Elbow
56	1WB-11	Hydraulic Hose
57	1WB-05	Hydraulic Hose

3. Remove the filler cap from the power unit reservoir and fill with Dexron III ATF or ISOVG 32 Hydraulic Oil or equivalent.

#### **2.4.7 Air Valve and Air Tubing Installation**

Install the air valve and air tubing as follows:

1. Refer to figure 2-9 and install the air valve (parts list item 11) on control post with provided hardware. There will be two small holes on the control post for mounting screws.

2. Install the air tubing as shown in figure 2-11 using the parts listed in the figure. Most tubing is pre-installed. Connect front and rear "T" fittings. To connect air tubing, push air tubing into hole on fitting. The blue lock rings will lock the air tubing in place when you insert tube. Use air tubing supplied in the hardware kit to connect the air valve control located on the control post, to the "T" fitting under the front power runway next to the hydraulic fitting.

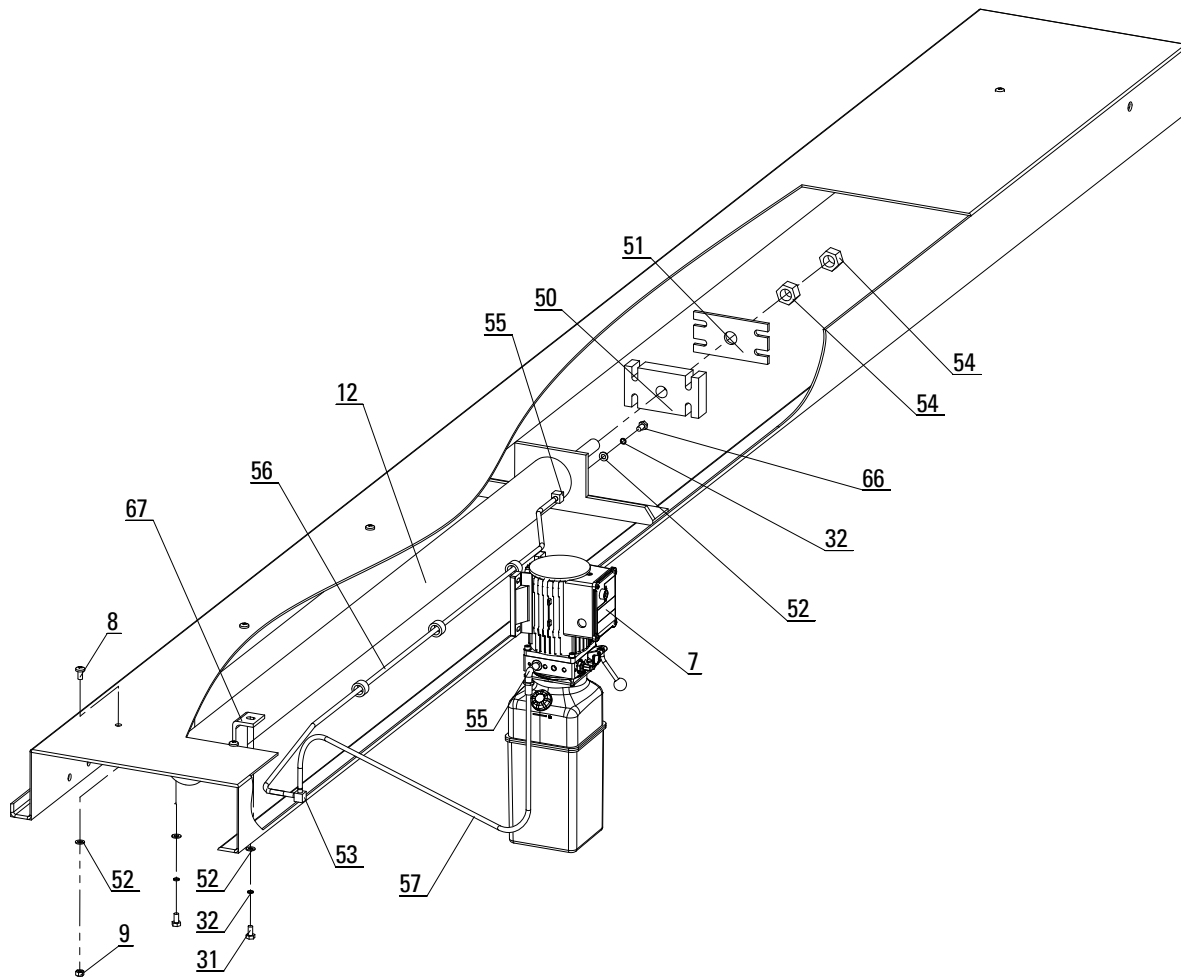

**Figure 2-10. Hydraulic Lines Installation**

### 2.4.8 Installation of Remaining Columns

Install the remaining columns as follows:

1. Refer to figure 2-3 and position the three remaining posts in proper corners with cable mounting holes closest to center of lift. The column locations, and item/part numbers/descriptions from the parts listing are as follows:

Corner Location	Item	Part Number	Description
Front Left (Control Column - already anchored)	65	H4P-R1100G	Column A
Front Right	64	H4P-2200G	Column C
Rear Left	64	H4P-2200G	Column C
Rear Right	1	H4P-2100G	Column Assembly

**NOTE**

**DO NOT ANCHOR POSTS AT THIS TIME!**

2. Make sure that posts are next to nylon blocks on cross tubes.

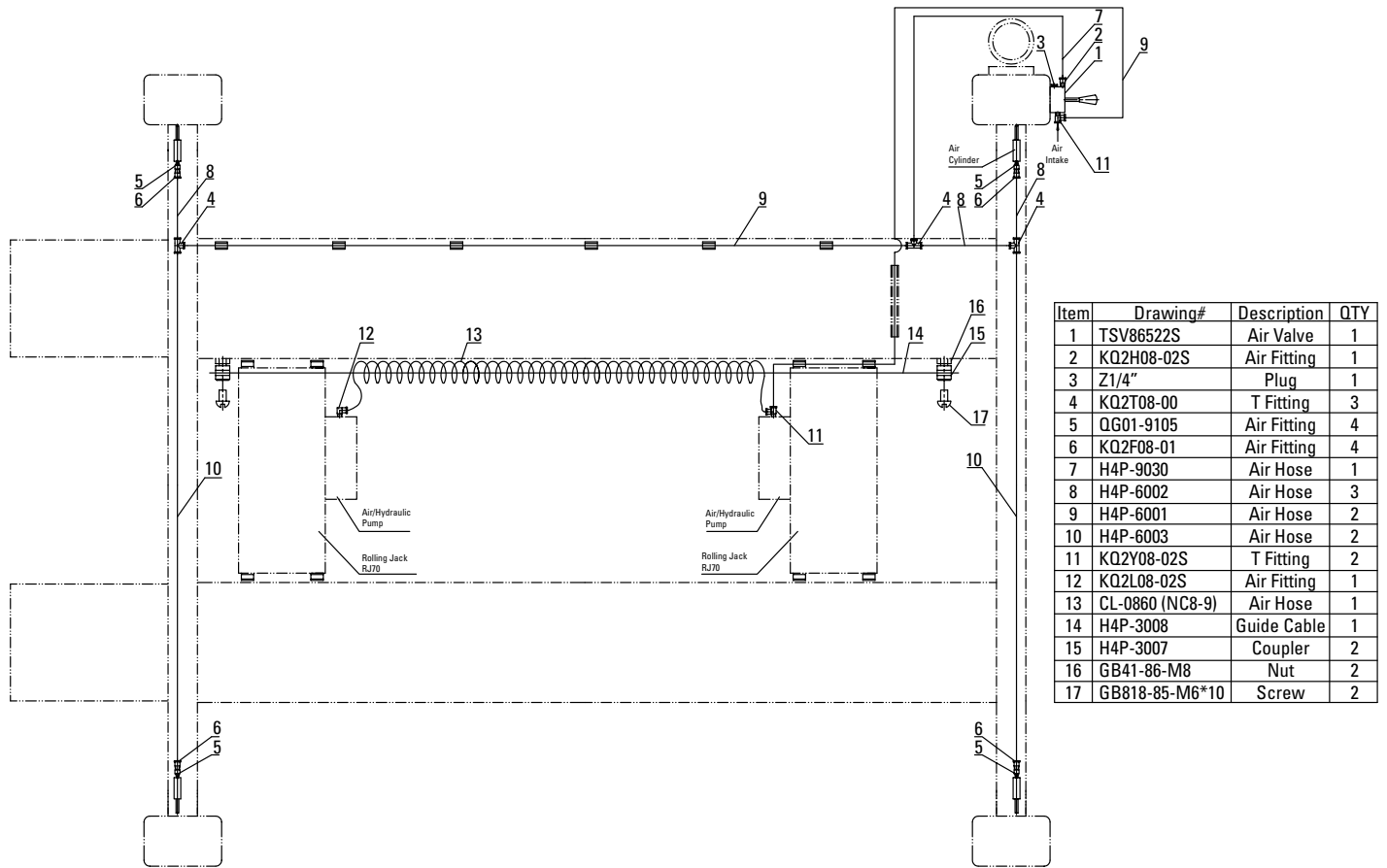

**Figure 2-11. Air Hose Routing and Assembly**

**NOTE**

When installing cables in the next step verify that the cable is on the safety lock roller.

3. Push the end of the cables through the cable mounting holes located on the top of posts.
4. Use the provided lock nuts to secure the cables to the top of the posts (item 60, WG-6 M22×2.5 Lock Nuts). Tighten lock nut until the threads of the cable are even with the nylon lock ring in the nut. Further adjustments will be made later in installation.

**WARNING!**

Failure to comply with this warning could result in death or injury. In the following step have a certified electrician make the electrical hook-up to the power unit. Motor cannot run on 50 Hz without a physical change to motor.

5. Size wire for 20 amp circuit. Use separate circuit for each power unit. Protect each circuit with time delay fuse or circuit breaker. For single phase 208-230V, use 20 amp fuse. Three phase 208-240V, use 15 amp fuse. For three phase 400V and above, use 10 amp fuse. For 3Ø wiring see Fig. on next page. All wiring must comply with NEC and all local electrical codes.

## Single Phase Power Unit

MOTOR OPERATING DATA TABLE - SINGLE PHASE

LINE VOLTAGE	RUNNING MOTOR VOLTAGE RANGE
208-230V 50Hz.	197-253V
208-230V 60Hz.	197-253V

NOTE: 60Hz. Single phase motor CAN NOT be run on 50Hz. line without a physical change in the motor.

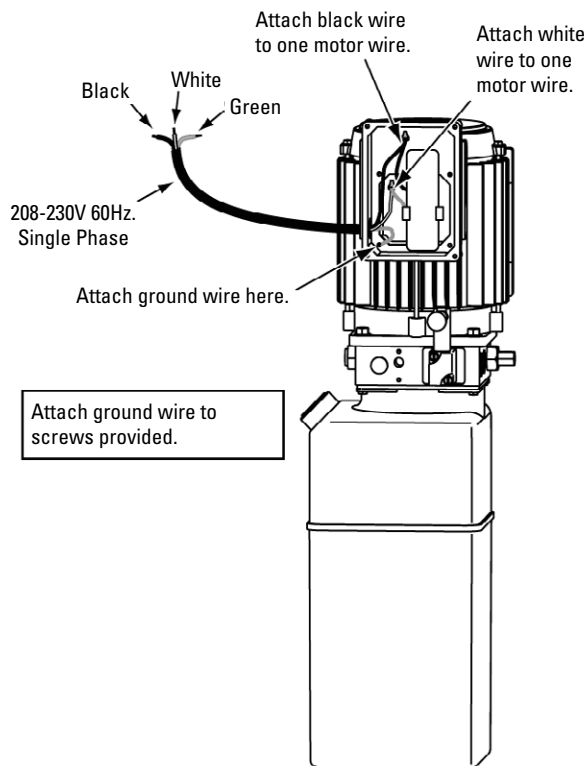
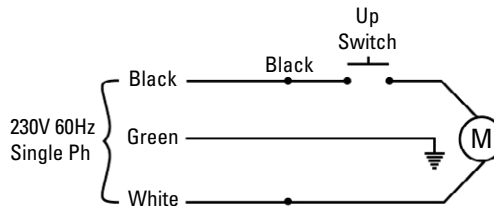

MOTOR OPERATING DATA TABLE - THREE PHASE

LINE VOLTAGE	RUNNING MOTOR VOLTAGE RANGE
208-240V 50/60Hz.	197-253V
400V 50Hz.	360-440V
440-480V 50/60Hz.	396-528V
575V 60 Hz.	518-632V

NOTES:

1. Unit not suitable for use in unusual conditions.
2. Control Box must be field mounted to power unit.
3. Motor rotation is counter clockwise from top of motor.

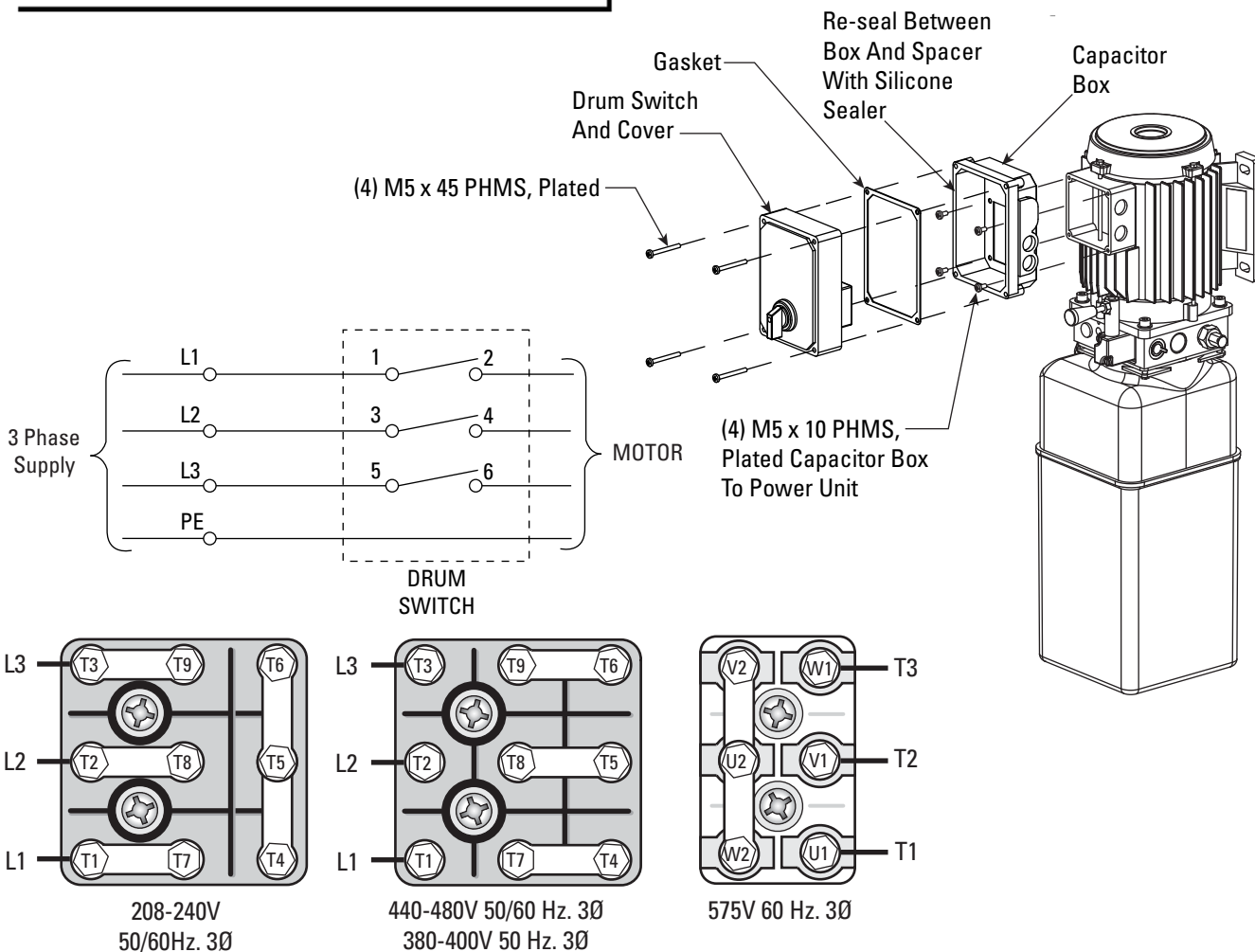



7. Connect a 100-psi air supply to air valve located on the control post.
8. Lower the lift as follows:
  - a. Raise the lift until the latches clear the safety racks inside each column.
  - b. Switch the air valve to release the safety lock.

**CAUTION!**

Failure to comply with this caution could result in damage to the lift. In the following step pay attention to the lowering speed of all four corners. Make sure they are moving down in a same speed. Stop lowering the lift by release the lowering level on the power unit and switching the air valve to lock position if any corner stop moving or slower in descent.

- c. Press the lowering lever at the power unit to lower the lift. While lowering the lift to the floor, check the nylon guide on the crossbeam to make sure it is against the control post. If not, pull the crossbeam to the control post as you lower the lift and hold crossbeam in position until lift comes to rest on blocks of wood. This will align the control post to the lift.

**CAUTION!**

Failure to comply with this caution could result in damage to the lift. In the following step locate and plumb the remaining three posts before drilling any holes in floor.

10. Level and anchor the remaining posts to the floor with the provided hardware by following the steps given in paragraph 2.4.5 on page 10. Torque all anchor bolts to 65-85 foot-pounds of torque. Remember, the nylon block must rest against the post.

### **2.4.9 Leveling Lift**

Level the lift by doing the following steps in the order given:

1. After all of the post have been anchored and leveled, raise unit and set on the locks. Place level on crossbeam.

**NOTE**

In the following step, you may have to loosen the nut under top plate to make adjustments.

2. To adjust the level, use the lock rod nuts located on the top of each post. Adjust the proper posts to level out the lift. Place level on each runway and crossbeam and check level.
3. After leveling is complete, tighten the nut on the lock rod underneath the top plate on each post.

**NOTE**

In the following step, you may need to use locking pliers to hold the cable from turning when adjusting the locking nut.

4. Raise lift off all locks until cables are supporting the lift. Adjust the cable lock nut located on the top of each post until lift is level on crossbeams and runways.

5. Reinstall all crossbeam covers.
6. Install M16 lockwasher, M16 flat washer, and M16x30 Bolt through bottom of ladder bar and into column as shown.

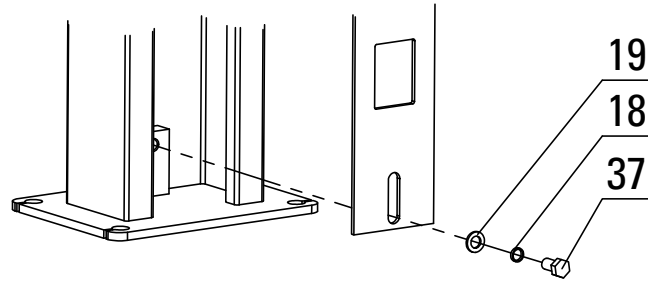

#### 2.4.10 Installation of Tire Stoppers and Approach Ramps

Refer to figure 2-12 and install the tire stoppers and approach ramps as follows:

1. Using the following hardware from the parts list install the tire stoppers (item 6) as shown:

Item	Drawing Number	Description
21	B10-12x20	M12x20 Bolts
22	B40-12	Ø12 Lock Washer
23	B45-12	Ø12 Flat Washer

2. Using the following hardware from the parts list install the approach ramps (item 5) as shown:

Item	Drawing Number	Description
24	H4P-4006	Hinge Pin
25	B52-3x40	Ø5x40 Row Pin

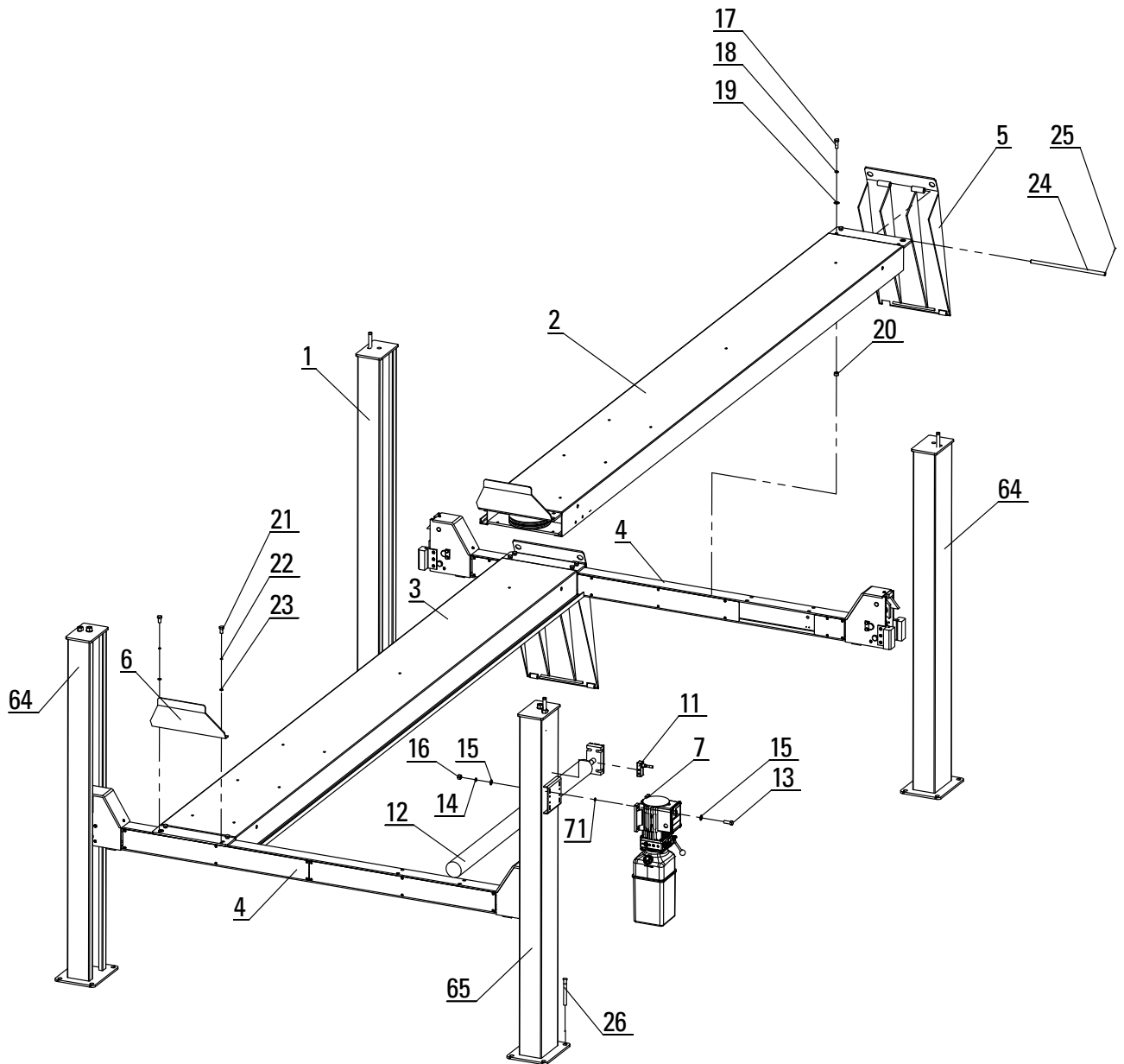

**Figure 2-12. Installation of Tire Stoppers and Approach Ramps**

**NOTE**

Lubricate all cable sheaves, bearings, and shafts with a grease gun prior to operating the lift.

### 3. Operating Instructions

#### 3.1 Safety Procedures

**WARNING!**

Failure to adhere to the following can result in death or injury, or damage to the equipment and vehicle. All personnel will be made aware of this warning and trained in the use and care of the lift.

# SAFETY INSTRUCTIONS

- **Never** allow unauthorized or untrained persons to operate lift or rolling jacks.
- **Shop** Policy should prohibit customers or non-authorized persons from being in shop area while lift is in use.
- **Thoroughly** train all employees in the use and care of lift and rolling jacks.
- **Be Sure** no one is standing in front or behind lift while vehicle is being driven onto or backed off the lift.
- **DO NOT** allow rear tires or portion of vehicle to interfere with ramp/chocks.
- **Be Sure** front wheel stops are in raised position before driving vehicle onto lift.
- **Never** allow front wheels to strike the front wheel stops.
- **DO NOT** permit employees or customers on lift when it is either being raised or lowered.
- **Always** stand clear of lift when raising or lowering and observe “Pinch Points” Warning.
- **Never** overload lift: capacity of lift is 14,000 lbs. (7,000 lbs. per axle). CAPACITY SHOULD NOT BE EXCEEDED.
- **Always** engage parking brake and use the rear wheel chocks to keep the vehicle from rolling freely on the runways.
- **Always** lower lift on locks before working on vehicle.
- **Keep** area around lift clean of tools, debris, grease, and oil.
- **Always** keep runway clean.
- **Replace** all caution, warning, or safety related decals on the lift when unable to read or missing.
- **For Rolling Jack Safety Instructions** see Rolling Jack Installation, Operation and Maintenance Instructions in the rolling jack box.
- **Never** use work step while lift is in a raised position.

### 3.2 Daily Pre-Operation Check (8-Hours)

#### **NOTE**

Occupational Safety and Health Administration (OSHA) and the American National Standards Institute (ANSI) require users to inspect lifting equipment at the start of every shift. These and other periodic inspections are the responsibility of the user.

#### **WARNING!**

Failure to perform the daily pre-operational check can result in expensive property damage, lost production time, serious personal injury, and even death. The safety latch system must be checked and working properly before the lift is put to use.

The daily pre-operational check consists of the following:

1. Check safety lock audibly and visually while in operation.
2. Check safety latches for free movement and full engagement with rack.
3. Check hydraulic connections, and hoses for leakage.
4. Check chain connections - bends, cracks-and loose links.
5. Check cable connections- bends, cracks-and looseness.
6. Check for frayed cables in both raised and lowered position.
7. Check snap rings at all rollers and sheaves.
8. Check bolts, nuts, and screws and tighten if needed.
9. Check wiring & switches for damage.
10. Keep base plate free of dirt, grease or any other corrosive substances.
11. Check floor for stress cracks near anchor bolts.

### 3.3 Controls

The controls are located on the column as shown in figure 3-1 and their use and function given in table 3-1 below.

**Table 3-1. Controls**

Item No.	Type	Purpose
1	Push button switch	Controls electrical power to the power unit. Push to raise lift.
2	Lower lever	Used to relieve hydraulic pressure when pressed down.
3	Reservoir cap	Cap for the power unit fluid reservoir. Remove to add fluid.

### 3.4 Operation

**WARNING!** To avoid personal injury and/or property damage, permit only trained personnel to operate lift.

After reviewing these instructions, get familiar with lift controls by running the lift through a few cycles before loading vehicle on lift.

Observe and heed SAFETY and WARNING labels on the lift.

1. **Loading:** Lift must be fully lowered and no one in service bay while the vehicle is brought on lift.
2. If lift is equipped with rolling jacks, jacks must be fully lowered and the rear jack pushed toward center of lift to provide under car clearance.
3. Stop vehicle when it contacts the front wheel stops. At all times, be sure rear wheels are forward of the ramp/chocks and the ramp/chocks will clear tires when the lift is raised, Fig. 1. Driver and passengers must exit before raising.
4. Place triangular wheel chocks on each side of one of the rear tires, Fig. 1.
5. **To Raise Lift:** Push the “**RAISE**” button on the power unit. Release button at desired height, Fig. 2.
6. For Rolling Jack Operating Instructions see Rolling Jack Installation, Operation and Maintenance Instructions in the rolling jack shipping carton.
7. **Before Lowering Lift:** Be sure no one is in the lift area and that all tools, tool trays, etc. have been removed from under the lift and vehicle.

**WARNING!** The runways, ramps and connecting yokes at each end of lift are designed to rest on the floor when fully lowered. Observe pinch point warning decals, Fig. 3.

8. **Repeat Step 2.**
9. **To Lower Lift:** If lift has been resting on the locking latches, lift must be raised high enough for all four latches to clear the latch plate slots inside the columns.
10. Actuate the latch release valve on the power unit column to disengage all four locking latches, Fig. 2. Hold actuator until lift has fully lowered.

**Note:** If actuator on air valve is released, the latches will automatically reset to the engaged position.

11. Push the lowering handle on the power unit to lower lift, Fig. 2. Lowering speed can be controlled by the force applied to the lowering handle.
12. Observe lift and vehicle to be sure lift is level while being lowered. If not, STOP repeat Steps 10 through 13.
13. Fully lower lift, remove the triangular wheel chocks and check to be sure area is clear before removing vehicle from lift, Fig. 1.
14. If your lift is not operating properly, DO NOT use until adjustments or repairs have been made by qualified lift service personnel.

**WARNING!** Keep hands clear of yoke ends while the lift is being raised or lowered, Fig. 3.

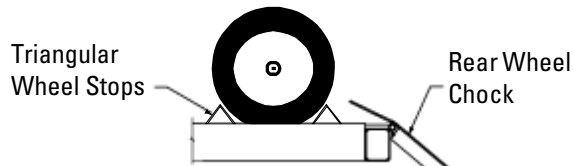

Fig. 1

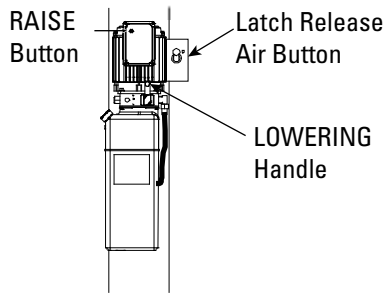

Fig. 2

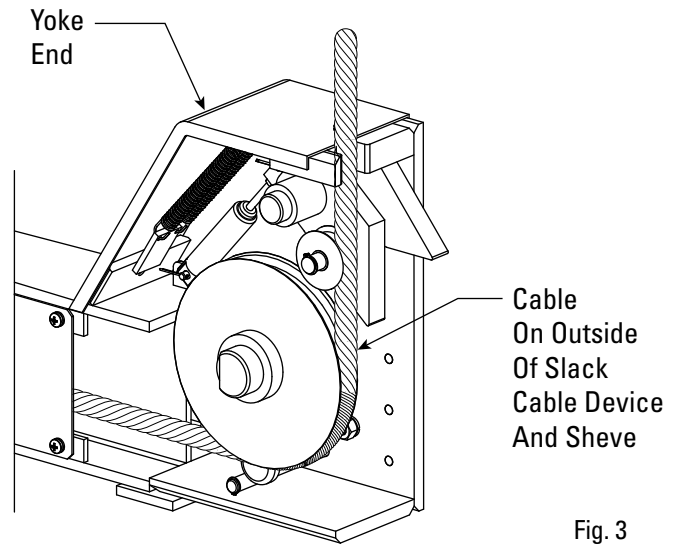

Fig. 3

### 3.4.1 Basic Lift Operation

All operations will be accomplished according to the operating instructions, "Lifting It Right" and "Safety Tips" as posted in the lift area.

### 3.4.2 Optional Wheel Alignment Kit Operation

The Optional Wheel Alignment Kit is operated the same as any standard wheel alignment kit. Since the wheel alignment specifications vary according to vehicle, the vehicle manufacturer's maintenance manual must be used.

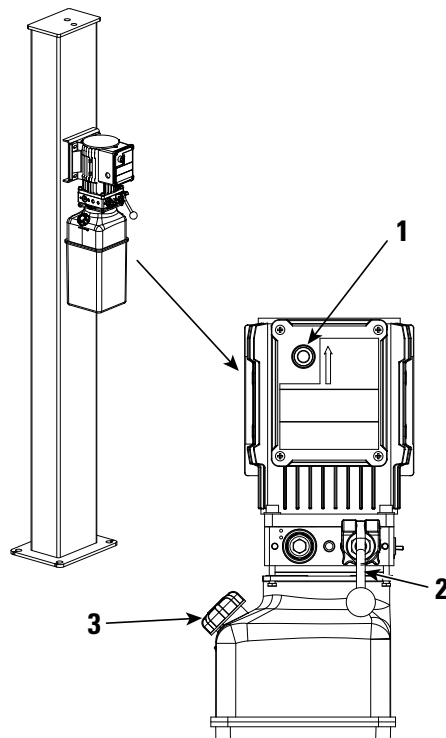

Figure 3-1. Controls

## 4. Maintenance and Troubleshooting

### 4.1 Maintenance

#### 4.1.1 Owner/Employer Responsibilities

The owner/employer is responsible for, and will do the following:

1. Shall establish procedures to periodically maintain, inspect and care for the lift in accordance with the manufacturer's recommended procedures to ensure its' continued safe operations.
2. Shall provide necessary lockout / tag outs of energy sources per ANSI Z244.1 – 1982 before beginning any lift repairs.
3. Shall not modify the lift in any manner without prior written consent of the manufacturer.
4. Shall display the operating instructions, "Lifting It Right" and "Safety Tips" supplied with the lift in a conspicuous location in the lift area convenient to the operator.
5. Shall make sure that lift operators are instructed in the proper and safe use and operation of the lift using the manufacturer's instructions and "Lift It Right" and "Safety Tips" supplied with the lift.

#### 4.1.2 Periodic Maintenance Schedule

The periodic maintenance given in the following paragraphs is the suggested minimum requirements and minimum intervals; accumulated hours or monthly period, whichever ever comes sooner.

### **WARNING!**

Failure to heed this warning can result in death or serious injury, or damage to equipment. If you hear a noise not associated with normal lift operation, or, if there is any indication of impending lift failure - cease operation immediately! - Inspect, correct and/or replace parts as required.

Periodic maintenance is to be performed on a daily, weekly, and yearly basis as given in the following paragraphs.

##### 4.1.2.1 Daily Pre-Operation Check (8-Hours)

This daily pre-operational check is shown in the Operation Chapter as it is performed on a daily basis before use of the lift.

##### 4.1.2.2 Weekly Maintenance (every 40-Hours)

On a weekly basis, perform the following checks:

1. Check for any loose anchor bolts. Retighten as necessary. Do not use an impact wrench.
2. Check floor for stress cracks near anchor bolts.
3. Check hydraulic oil level.
4. Check and tighten bolts, nuts, and screws.
5. Check all cable sheaves/assembly for free movement or excessive wear on cable sheave shaft.

##### 4.1.2.3 Yearly Maintenance



The following shall be accomplished on a yearly basis

1. Lubricate cable sheaves and shafts.
2. Check for excessive wear of cables. Replace as necessary.
3. Change the hydraulic fluid - good maintenance procedure makes it mandatory to keep hydraulic fluid clean. No hard fast rules can be established; - operating temperature, type of service, contamination levels, filtration, and chemical composition of fluid should be considered. If operating in dusty environment shorter interval may be required.

#### **4.1.2.4 Special Maintenance Tasks**

The following items should only be performed by a trained maintenance expert.

1. Replacement of hydraulic hoses.
2. Replacement of chains and rollers.
3. Replacement of cables and sheaves.
4. Replacement or rebuilding air and hydraulic cylinders as required.
5. Replacement or rebuilding pumps / motors as required.
6. Checking of hydraulic cylinder rod and rod end (threads) for deformation or damage.

#### **NOTE**

Relocating or changing components may cause problems. Each component in the system must be compatible; an undersized or restricted line will cause a drop in pressure. All valve, pump, and hose connections should be sealed and/or capped until just prior to use. Air hoses can be used to clean fittings and other components. However, the air supply must be filtered and dry to prevent contamination. Most important - cleanliness → contamination is the most frequent cause of malfunction or failure of hydraulic equipment.

## **4.2 Troubleshooting**

The common problems that may be encountered and their probable causes are covered in the following paragraphs:

Paragraph:	Problem:
4.2.1	Motor Does Not Operate
4.2.2	Motor Functions But Lift Will Not Rise
4.2.3	Oil Blows Out Breather Of Power Unit
4.2.4	Motor Hums and Will Not Run
4.2.5	Lift Jerks Going Up and Down
4.2.6	Oil Leaks
4.2.7	Lift Makes Excessive Noise

### **4.2.1 Motor Does Not Operate**

Failure of the motor to operate is normally caused by one of the following:

1. Breaker or fuse blown.
2. Motor thermal overload tripped. Wait for overload to cool.
3. Faulty wiring connections; call electrician.
4. Defective up button call electrician for checking.

### **4.2.2 Motor Functions but Lift Will Not Rise**

If the motor is functioning, but the lift will not rise do the following in the order given:

1. A piece of trash is under check valve. Push handle down and push the up button at the same time. Hold for 10-15 seconds. This should flush the system.
2. Check the clearance at the plunger valve of the lowering handle. There should be 1/16 in.
3. Remove the check valve cover and clean ball and seat.

**WARNING!**

Failure to properly relieve pressure in the following step can cause injury to personnel. This lift uses Dexron III ATF or ISOVG32 Hydraulic Oil at a high hydraulic pressure. Be familiar with its toxicological properties, precautionary measures to take, and first aid measures as stated in the Safety Summary before performing any maintenance with the hydraulic system.

4. Oil level too low. Oil level should be just under the vent cap port when the lift is down. Relieve all hydraulic pressure and add oil as required.

#### **4.2.3 Oil Blows out Breather of Power Unit**

If oil blows out of the breather of the power unit, take the following actions:

**WARNING!**

Failure to properly relieve pressure in the following step can cause injury to personnel. Failure to properly relieve pressure in the following step can cause injury to personnel. This lift uses Dexron III ATF or ISOVG32 Hydraulic Oil at a high hydraulic pressure. Be familiar with its toxicological properties, precautionary measures to take, and first aid measures as stated in the Safety Summary before performing any maintenance with the hydraulic system.

1. Oil reservoir overfilled. Relieve all pressure and siphon out hydraulic fluid until at a proper level
2. Lift lowered too quickly while under a heavy load. Lower the lift slowly under heavy loads.

#### **4.2.4 Motor Hums and Will Not Run**

If the motor hums but fails to run, take the following actions:

1. Impeller fan cover is dented. Remove cover and straighten.
2. Lift overloaded. Remove excessive weight from lift.

**WARNING!**

The voltages used in the lift can cause death or injury to personnel. In the following steps, make sure that a qualified electrician is used to perform maintenance.

3. Faulty wiring..... Call electrician
4. Bad capacitor..... Call electrician
5. Low voltage..... Call electrician
6. Lift overloaded. Remove excessive weight from lift

#### **4.2.5 Lift Jerks Going Up and Down**

If the lift jerks while going up and down, it is usually a sign of air in the hydraulic system. Raise lift all the way to top and return to floor. Repeat 4-6 times. Do not let this overheat power unit.

#### 4.2.6 Oil Leaks

Oil leak causes at the power unit and cylinders are normally caused by the following. Take the actions shown to fix the problem:

### **WARNING!**

Failure to heed this warning could cause serious injury or damage to the lift. Failure to properly relieve pressure in the following step can cause injury to personnel. This lift uses Dexron III ATF or ISOVG32 Hydraulic Oil. Be familiar with its toxicological properties, precautionary measures to take, and first aid measures as stated in the Safety Summary before performing any maintenance with the hydraulic system. Make sure that pressure is fully relieved before checking oil levels, loosening any hydraulic lines, or removing any cylinders.

1. Power unit: if the power unit leaks hydraulic oil around the tank-mounting flange check the oil level in the tank. The level should be at the MIN\_\_\_ level on the power unit tank.
2. Rod end of the cylinder: the rod seal of the cylinder is out. Rebuild or replace the cylinder.
3. Breather end of the cylinder: the piston seal of the cylinder is out. Rebuild or replace the cylinder.

#### 4.2.7 Lift Makes Excessive Noise

Excessive noise from the lift is normally caused by the following. Take the corrective actions shown.

1. Crossbeam ends are rubbing the columns. Readjustment needed.
2. Cylinder too tight, load lift half capacity and cycle up and down a few times to break in the cylinder.
3. May have excessive wear on cable sheaves or shafts. Check and replace as necessary.

### 5. Additional Inspection and Maintenance Procedures

This booklet contains important inspection and maintenance procedures for the lifting system on 4-post lifts. These procedures supplement the inspection and maintenance instructions earlier in the manual. Proper maintenance of equipment is essential for continued satisfactory performance during its service life.

### **WARNING!**

To avoid personal injury, permit only qualified personnel to inspect and/or perform maintenance on this equipment.

#### 5.1 Daily Inspection & Maintenance

1. Cleanliness: Cables, Columns, Runways and other lift parts should be kept free of corrosive agents, solvents, and road salts. If such agents are spilled or splashed on any lift component, immediately rinse thoroughly with water and wipe down with a clean rag. Spray wire rope cables as required with Penetrating Oil and wipe down.

### **WARNING!**

Failure to keep lift free of corrosive agents and solvents will lead to reduced component service life, cable failure, etc., which could result in property damage and/or personal injury.

2. Fasteners: Check all the attaching bolts and nuts for tightness.

**NOTE**

Air cylinder bolt and nut should be loose enough to allow movement of cylinder.

3. Cables: Check wire rope cables for wear or damage. Any cable with broken wires, severe corrosion, excessive stretch, deformed strands, variations in diameter (necking), or any change from its normal appearance, must be replaced. If any cable is found to be in need of replacement, the entire cable set must be replaced immediately. Refer to figures below.

Daily: Check cables and sheaves for wear. Observe for frayed cable strands. Wipe cables with a rag to detect hard to see small broken cable strands. Replace cables showing any broken strands.

Maximum Allowable Cable Necking	
Nom. Cable Diameters	Max. Reduction in Diameter
Up to 5/16"	1/64"
3/8" to 1/2"	1/32"
9/16" to 3/4"	3/64"
7/8" to 1 1/8"	1/16"
1 1/4" to 1 1/2"	3/32"



**Typical Good Cable**



**Cable With Broken Wires**

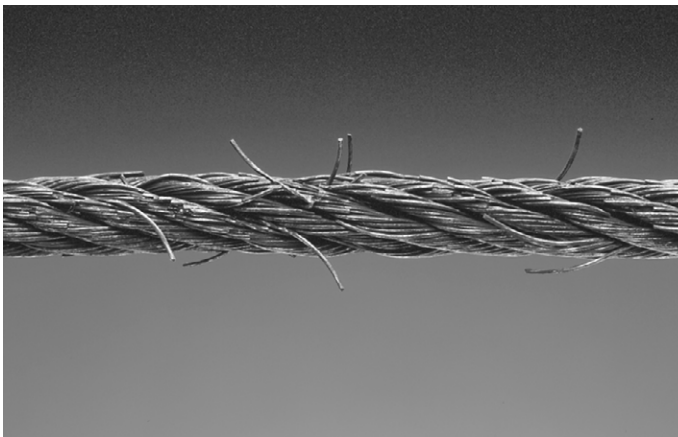

**Cable With Severe Corrosion**

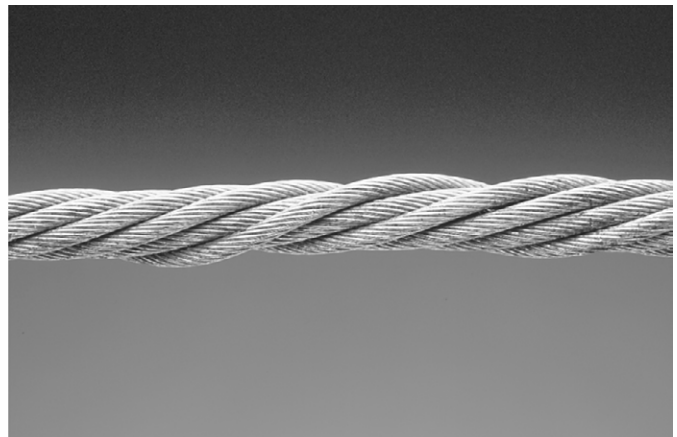

**Cable With Necking**

4. Sheaves: Check sheaves (pulleys) for wear or damage, i.e. wobble (tilt), cracks, loose on pin, or excessive noise during operation.
5. Sheave Pins: Check for loose or missing sheave (pulley) pins.
6. Locking Latches and Slack Cable Devices: Watch locking latches and slack cable devices during lift operation to ensure that latches work properly and line up with slots in latch plate located in columns.
7. Compressed Air Supply: Check filter/regulator/lubricator in air line to lift. Drain filter bowl and fill lubricator with oil as specified by manufacturer. Adjust oil feed according to manufacturer's instructions.

## **5.2 Monthly Inspection & Maintenance**

### **1. Cables**

1.1 Clean wire rope cables with lift in both lowered and raised position by spraying with Penetrating Oil and wiping the cable down.

1.2 Adjust cables using procedures on following pages. If there are no more threads available for adjustment, replace the cable. Do not use washers to stand off the nut to use previously used threads.

2. Slack Cable Device: Inspect slack cable devices using procedure on page 5.

3. Column Anchor Bolts: Check column anchor bolts for tightness. Re-torque anchors bolts to 65 ft/lbs. If anchors do not tighten to the required installation torque, replace concrete under each column base per installation instructions. Let concrete cure before installing lifts and anchors.

4. Columns: Look for corrosion, giving special attention to the area at the base of the column. Check severely corroded areas by pecking with an awl or welder's chipping hammer. If column is corroded through at any point it must be replaced immediately. If not corroded through, remove old paint and rust scale, then coat with a high quality corrosion resistant paint.

### **NOTE**

A thorough inspection of the lifting system must be performed quarterly by qualified lift service personnel; more frequently (monthly) under extreme service conditions such as outside installations or high usage (10 or more cycles per day, etc.).

## **5.3 Quarterly Inspection & Maintenance**

### **1. Cables**

1.1 Inspect cables in both lowered and raised position. The cables may also be viewed through various inspection holes and openings in yokes and runways. Check all the following:

- a. That cables have no broken wires visible, reference Daily Inspection & Maintenance.
- b. That cables are free of severe corrosion and pitting, reference Daily Inspection & Maintenance. A light surface corrosion on exposed outer wires is normal. Penetrating Oil should be applied during monthly periodic inspection.
- c. That there are no areas on the cable that have a greatly reduced diameter or "necking", reference Daily Inspection & Maintenance. When any cable is found with excessive necking, all cables must be replaced immediately.

- d. That cables do not have excessive stretch. It is normal for new cable to require adjustment during “break-in”, after which small periodic adjustments may be required. However, if a cable that has been in service for 6 months should suddenly require frequent adjustments or has used all the cable adjustment available, all cables must be replaced immediately.
- e. If any cable is found to be in need of replacement, the entire cable set must be replaced immediately.
- f. Cables are expendable items and should be replaced as a set every 20,000 cycles (estimated) or every 6 years, unless earlier replacement is indicated during inspection.

## 2. Sheaves and Pins

Inspect sheaves and pins in yokes and runways. Sheaves are expendable items. Sheaves and pins should be replaced when worn. Use of sheaves and pins with excessive wear will lead to reduced service life of cables.

### 2.1 Inspect sheaves (pulleys) in yoke ends with lift in lowered position or resting on the locking latches.

- a. Hold lowering handle down and pull on cable in column to create slack in cables.
- b. Check for excessive side to side wobble. Grasp rim of sheave and attempt to wobble (tilt) side to side. If sheaves wobble (tilt) more than 3/16” (4.8 mm) side to side or move up and down on shaft more than 1/32” (0.8 mm), the sheave and pin (shaft) should be replaced, refer figures below.

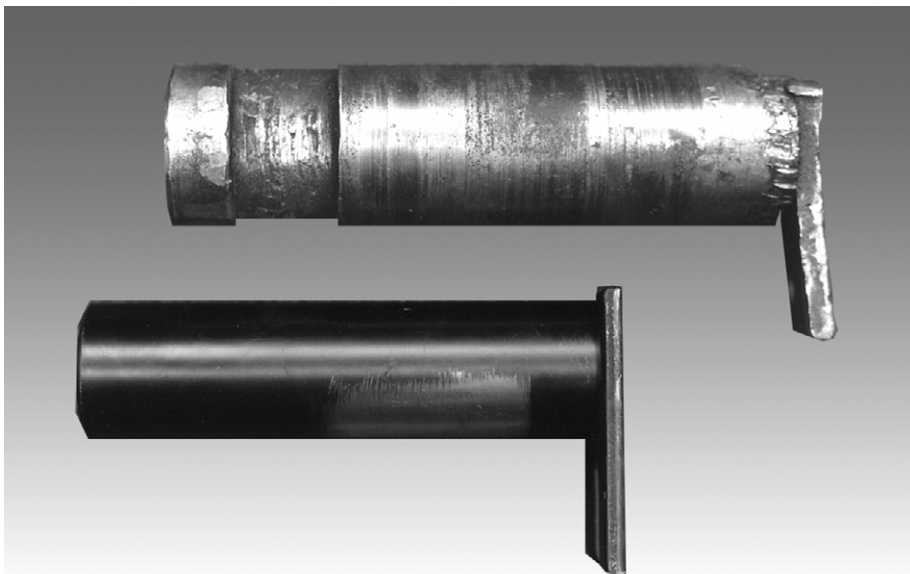
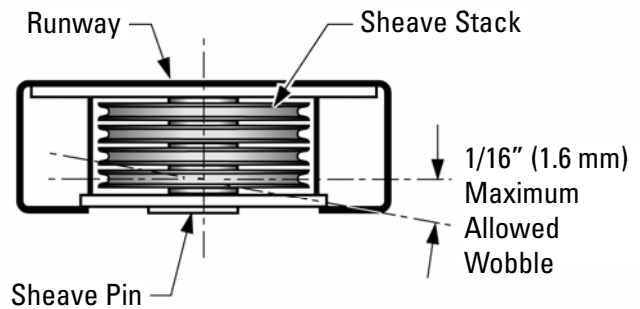
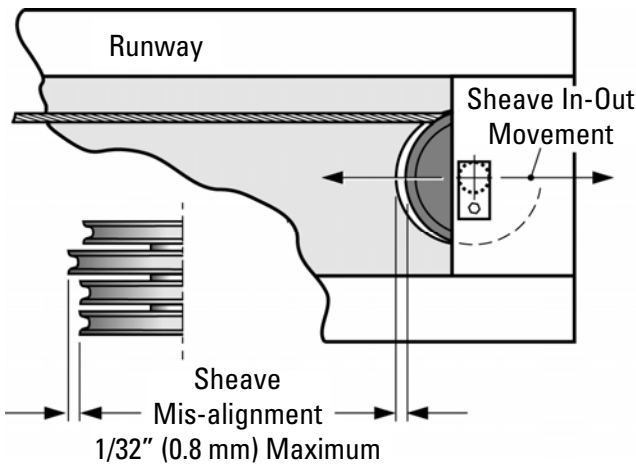

**TOP PIN With Excessive Scoring and Wear**

**BOTTOM PIN With Normal Wear**

- c. Check sheaves and replace if cracks are found.
- d. Check for ease of rotation. If sheaves do not turn freely, the sheave and sheave pin should be removed, inspected, lubricated, and reinstalled or replaced.

2.2 Fully raise lift. Inspect sheaves (pulleys) in runway ends with lift in raised position.

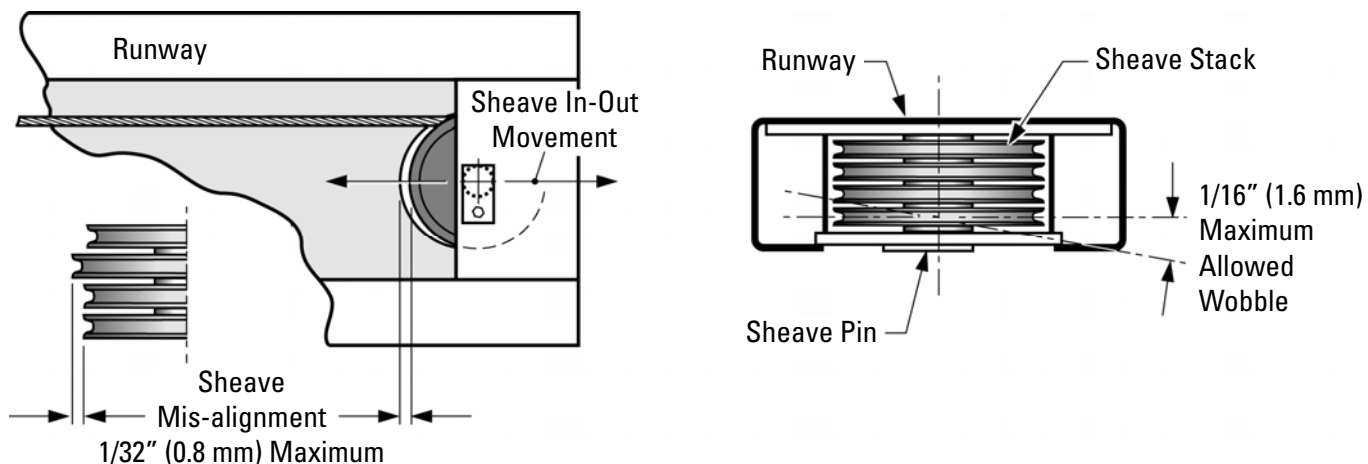

- a. Visually inspect alignment of sheaves, see figure above. Misalignment of sheave(s) indicates excessive wear; the sheave(s) and sheave pin should be removed and inspected. Replace as required.
- b. Hold lowering handle down to lower lift onto latches. Pull on cables under runway to create cable slack.
- c. Check for excessive side to side wobble. Grasp rim of sheave and attempt to wobble (tilt) side to side, refer to figures above. If sheaves wobble (tilt) more than 1/16" (1.6 mm) side to side, or move in and out more than 1/32" (0.8 mm), the sheave and sheave pin (shaft) should be replaced, refer to figures above.

### 3. Hydraulic Cylinder

Inspect the hydraulic cylinder mounting to the runway. Inspect cylinder and hydraulic hoses for leaks. Repair or replace as required.

- 1 Check and tighten the hydraulic cylinder rod nuts holding the cable pull bar.

### 4. TRACKS for Rolling Jack and Oil Drain Pan

Inspect rolling jack/oil drain pan tracks for cleanliness, corrosion, excessive wear or damage. Clean dirty tracks. Worn or damaged tracks must be repaired immediately.

**WARNING!**

Failure to do so will lead to reduced service life which could result in property damage and/or personal injury.

### 5. Latch Inspection and Adjustment

Check locking latches for proper operation. Inspect for worn or missing parts, Fig. 9a, and Fig. 9b. Replace worn or damaged parts and adjust as required.

- 1. Air Latches

Depress air valve and check latch operation on all four corners.

**NOTE**

Locking latches require 100 psi. min. to 120 psi. max. air pressure. Excessive air pressure can affect lock release mechanism and air cylinder wear.

## 2. Latch and Latch Bar Line-Up

Observe locking latches during lift operation to ensure that all latches line up with slots in latch bar located in all four columns. If not, relocate and/or re-shim columns.

1. Check slack cable devices for proper operation. Inspect for worn or missing parts. Replace worn or damaged parts as required.
2. Observe both locking latches and slack cable devices during lift operation to ensure that all latches line up with slots in latch bar located in all four columns.

## 5.4 Cable Adjustment

### 1. Initial Adjustment

Adjust cable with lift fully lowered. Loosen jam nut and tighten nut on cable stud on top of column until yoke end is raised 1/4" (6.4 mm) and back off nut one turn. Retighten jam nut. Repeat for all four cables. Refer to figures below.

**CAUTION!**

Cables must fit in slack cable arm rollers.

### 2. Final Adjustment

- a. Load a vehicle such as a 3/4 ton pickup or van on lift.
- b. Raise lift as high as it will travel (full height). You should hear the locking latches click through all latch slots simultaneously.
- c. Lower lift onto top latch position.
- d. Check clearance:
- e. Starting with the right front column, use a straight edge to mark the position of the yoke bottom on the column, Fig. 10.
- f. Raise lift to full height again. Mark second position, Fig. 10. If gap between two marks is less than 2", adjust locking latch bar to reach clearance of 2". Repeat for the other three columns.
- g. Adjust locking latch bar adjusting nut so that the bottom of the topmost latch bar slot is at least 2" below locking latch, Fig. 11. After adjustment, tighten jam nut underneath column top plate, Fig. 11.
- h. If entire 2" clearance cannot be attained by adjusting the locking latch bar, adjust the cable. Turn cable adjusting nut to raise the locking latch 2" above bottom of latch bar slot. Tighten cable jam nut.
- i. Lower lift and remove vehicle.
- j. Raise the lift to full height. LISTEN and WATCH as the first locking latch clicks into place. Synchronize the other three columns with this column by adjusting their cables so all four latches click at same time. Tighten jam nuts.

**CAUTION!**

When making changes to adjustment nuts on cable end or latch bar stud, always leave at least two threads showing between nut and stud end.



**NOTE**

Latches may not click in at the same time when vehicle is being raised. They should be close. Be sure all four corners have passed the locking latch bar slot before lowering lift on locking latches.

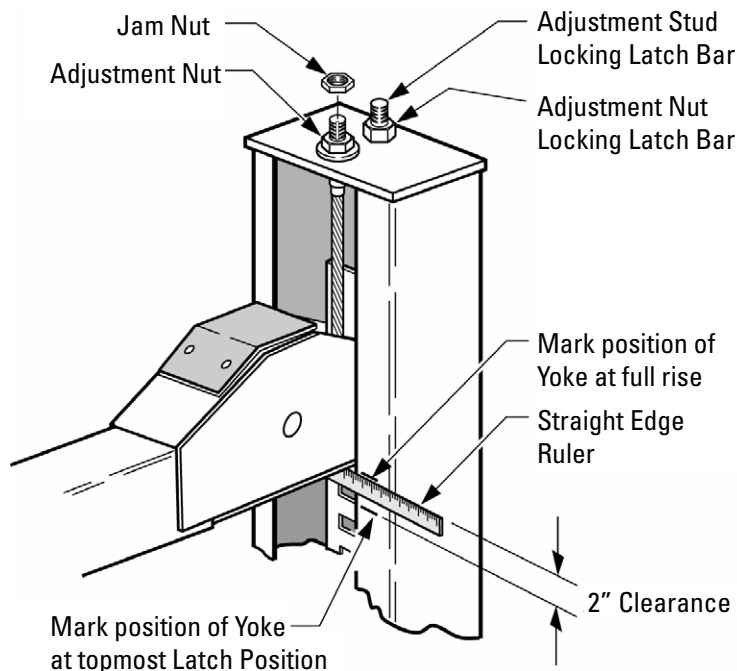

**Fig. 10**

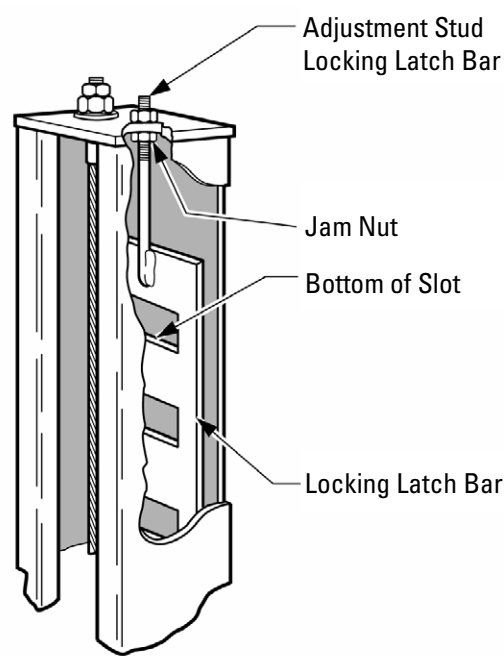

**Fig. 11**

## 6. Lift Lockout/Tagout Procedure

### Purpose

This procedure establishes the minimum requirements for the lockout of energy that could cause injury to personnel by the operation of lifts in need of repair or being serviced. All employees shall comply with this procedure.

### Responsibility

The responsibility for assuring that this procedure is followed is binding upon all employees and service personnel from outside service companies (i.e., Authorized Installers, contactors, etc.). All employees shall be instructed in the safety significance of the lockout procedure by the facility owner/manager. Each new or transferred employee along with visiting outside service personnel shall be instructed by the owner/manager (or assigned designee) in the purpose and use of the lockout procedure.

### Preparation

Employees authorized to perform lockout shall ensure that the appropriate energy isolating device (i.e., circuit breaker, fuse, disconnect, etc.) is identified for the lift being locked out. Other such devices for other equipment may be located in close proximity of the appropriate energy isolating device. If the identity of the device is in question, see the shop supervisor for resolution. Assure that proper authorization is received prior to performing the lockout procedure.

## Sequence of Lockout Procedure

- 1) Notify all affected employees that a lockout is being performed and the reason for it.
- 2) Unload the subject lift. Shut it down and assure the disconnect switch is "OFF" if one is provided on the lift.
- 3) The authorized lockout person operates the main energy isolation device removing power to the subject lift.
  - If this is a lockable device, the authorized lockout person places the assigned padlock on the device to prevent its unintentional reactivation. An appropriate tag is applied stating the person's name, at least 3" x 6" in size, an easily noticeable color, and states not to operate device or remove tag.
  - If this device is a non-lockable circuit breaker or fuse, replace with a "dummy" device and tag it appropriately as mentioned above.
- 4) Attempt to operate lift to assure the lockout is working. Be sure to return any switches to the "OFF" position.
- 5) The equipment is now locked out and ready for the required maintenance or service.

## Restoring Equipment to Service

- 1) Assure the work on the lift is complete and the area is clear of tools, vehicles, and personnel.
- 2) At this point, the authorized person can remove the lock (or dummy circuit breaker or fuse) & tag and activate the energy isolating device so that the lift may again be placed into operation.

## Rules for Using Lockout Procedure

Use the Lockout Procedure whenever the lift is being repaired or serviced, waiting for repair when current operation could cause possible injury to personnel, or for any other situation when unintentional operation could injure personnel. No attempt shall be made to operate the lift when the energy isolating device is locked out.

## 7. Operating Conditions

**Lift is not intended for outdoor use and has an operating ambient temperature range of 41°-104°F (5°-40°C).**

# 8. Illustrated Parts Breakdown

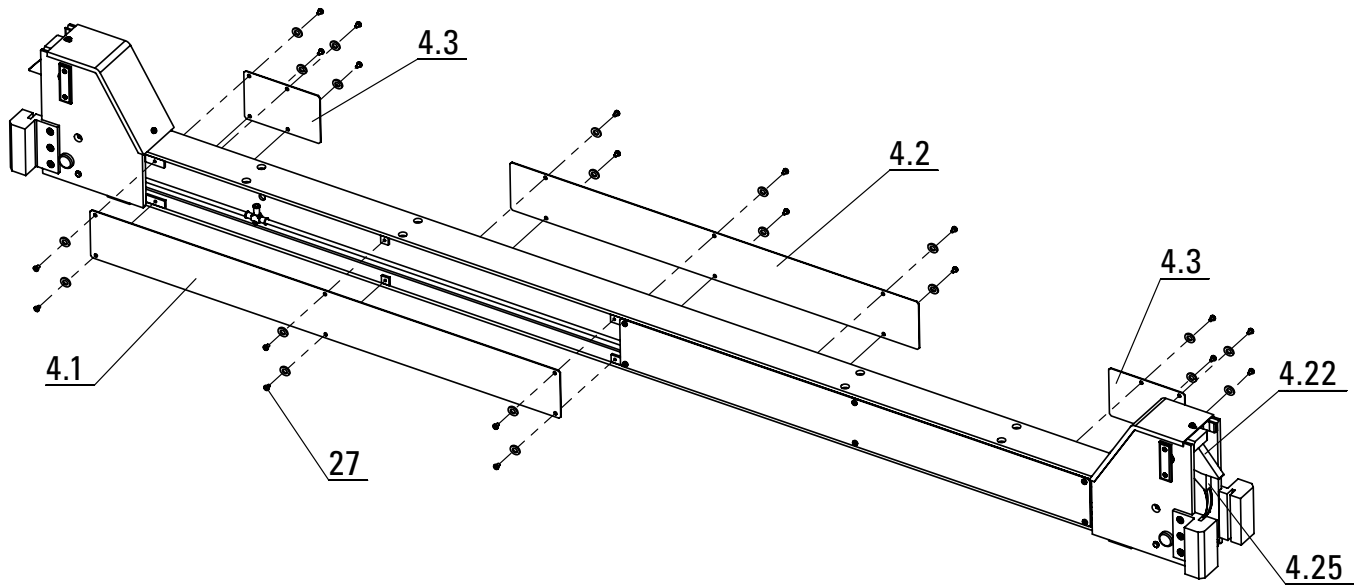

## Cross Beam End Assembly

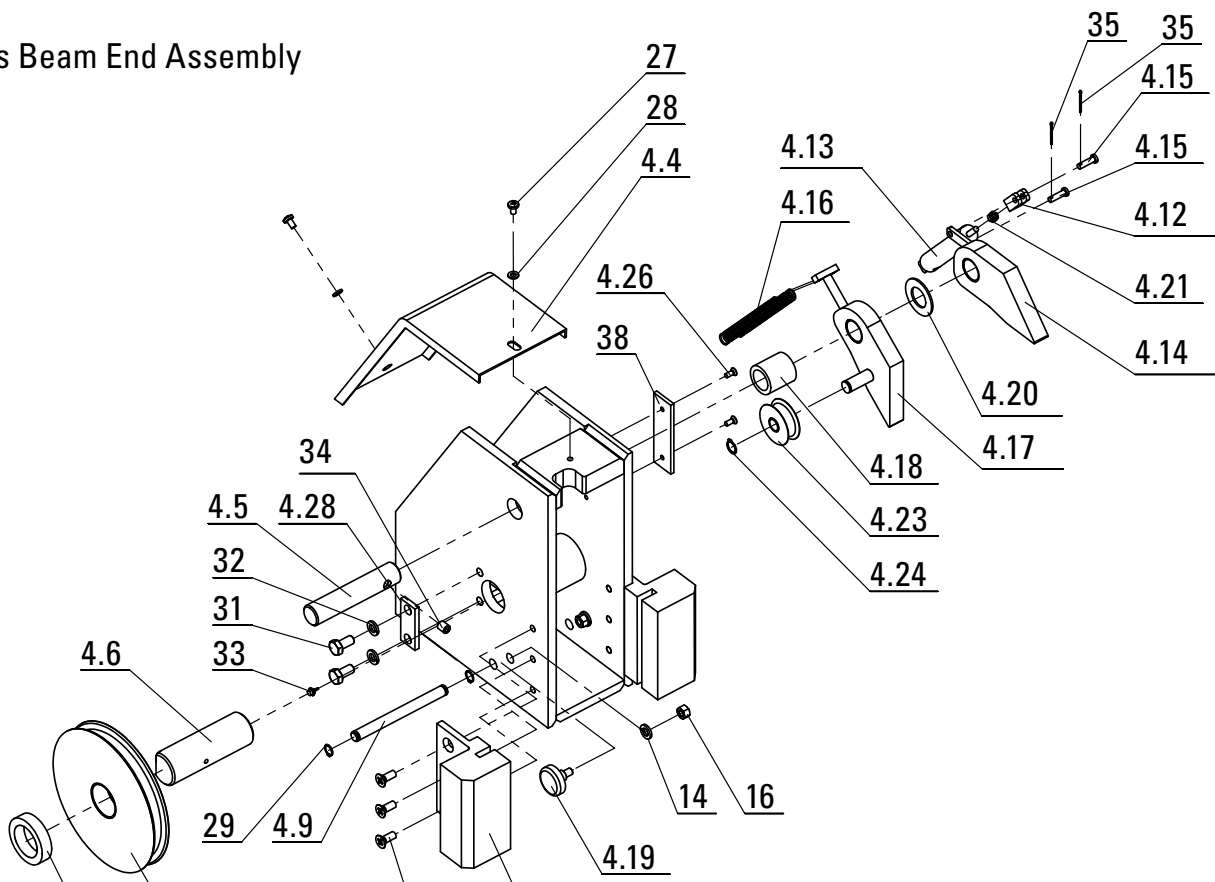

# Driving Ramp, Cable Pulley Assembly

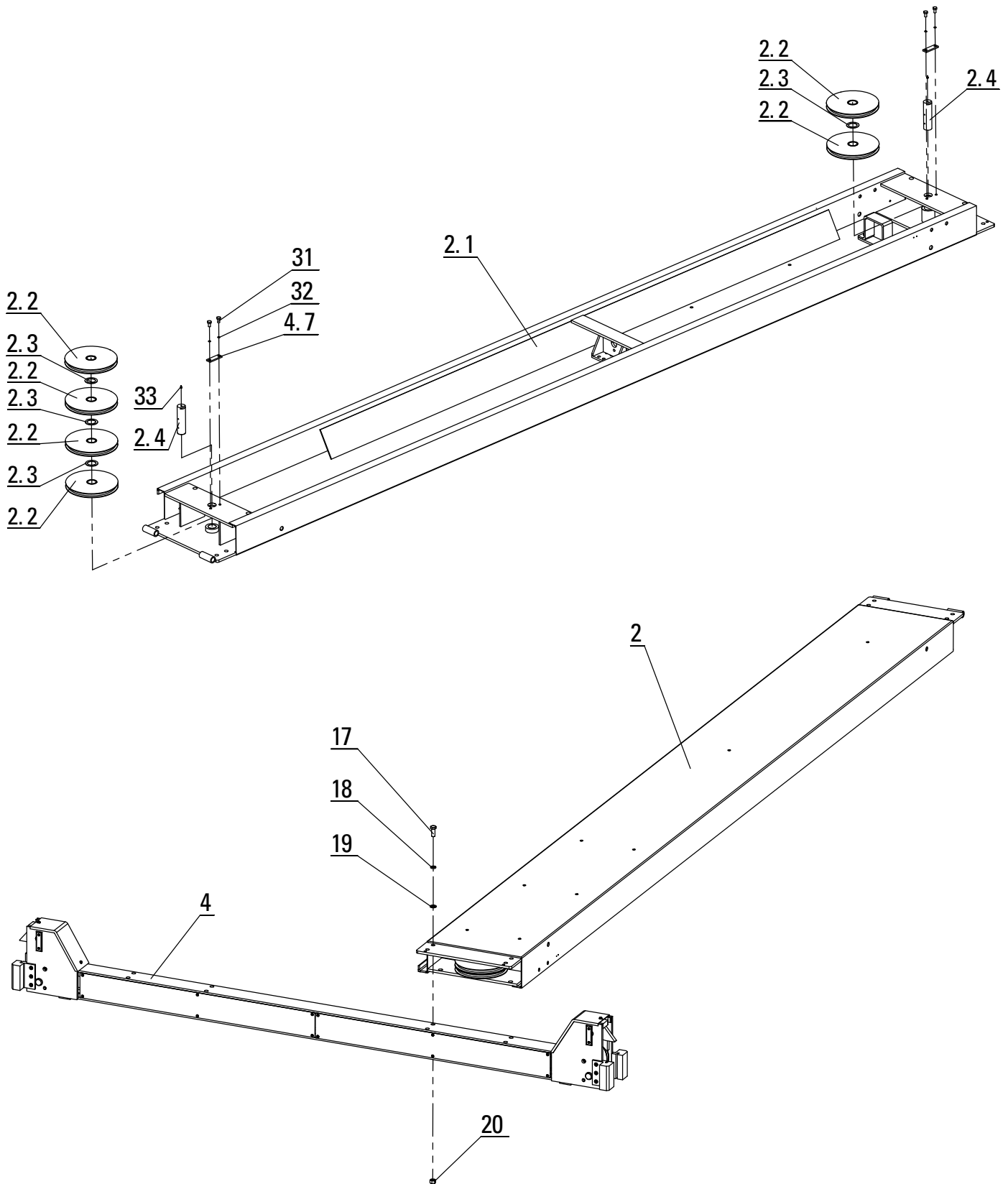

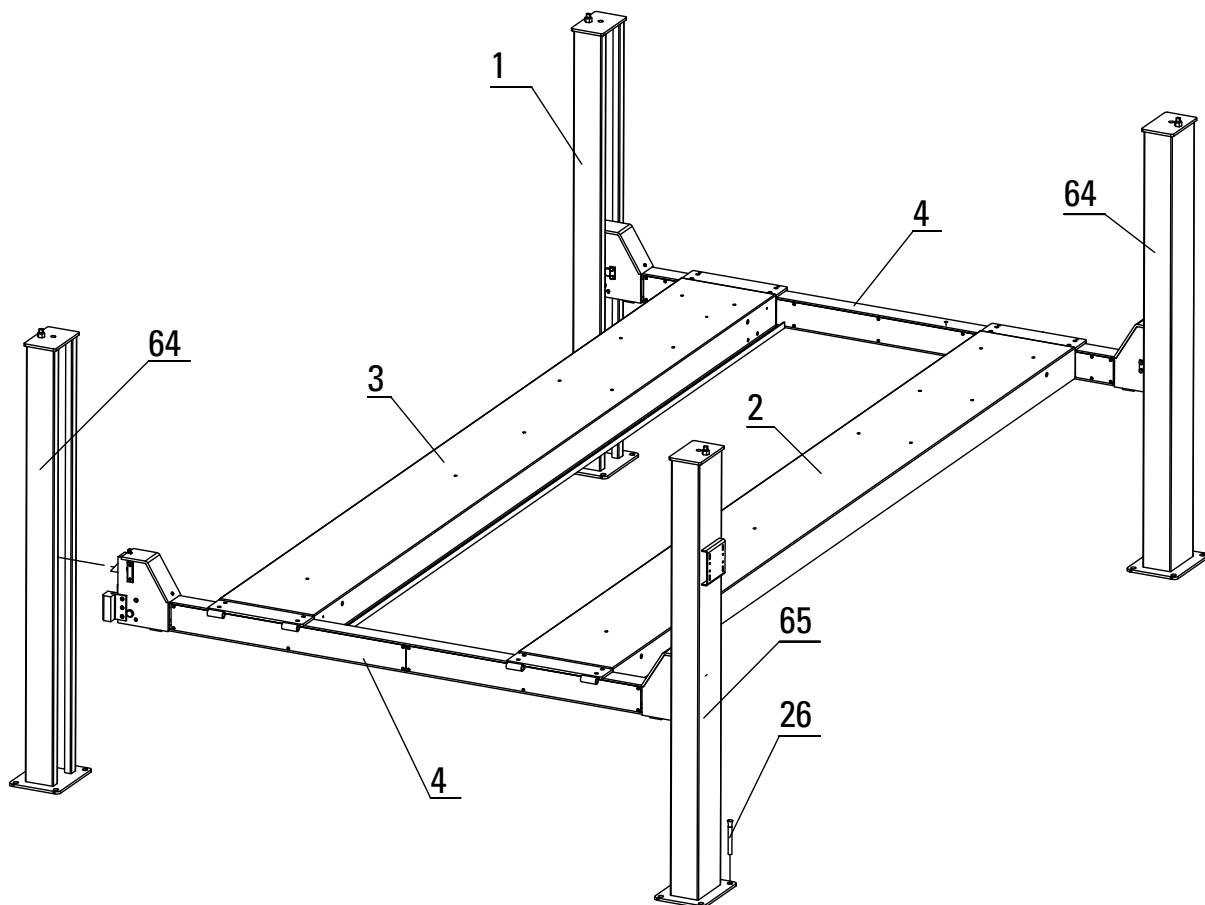
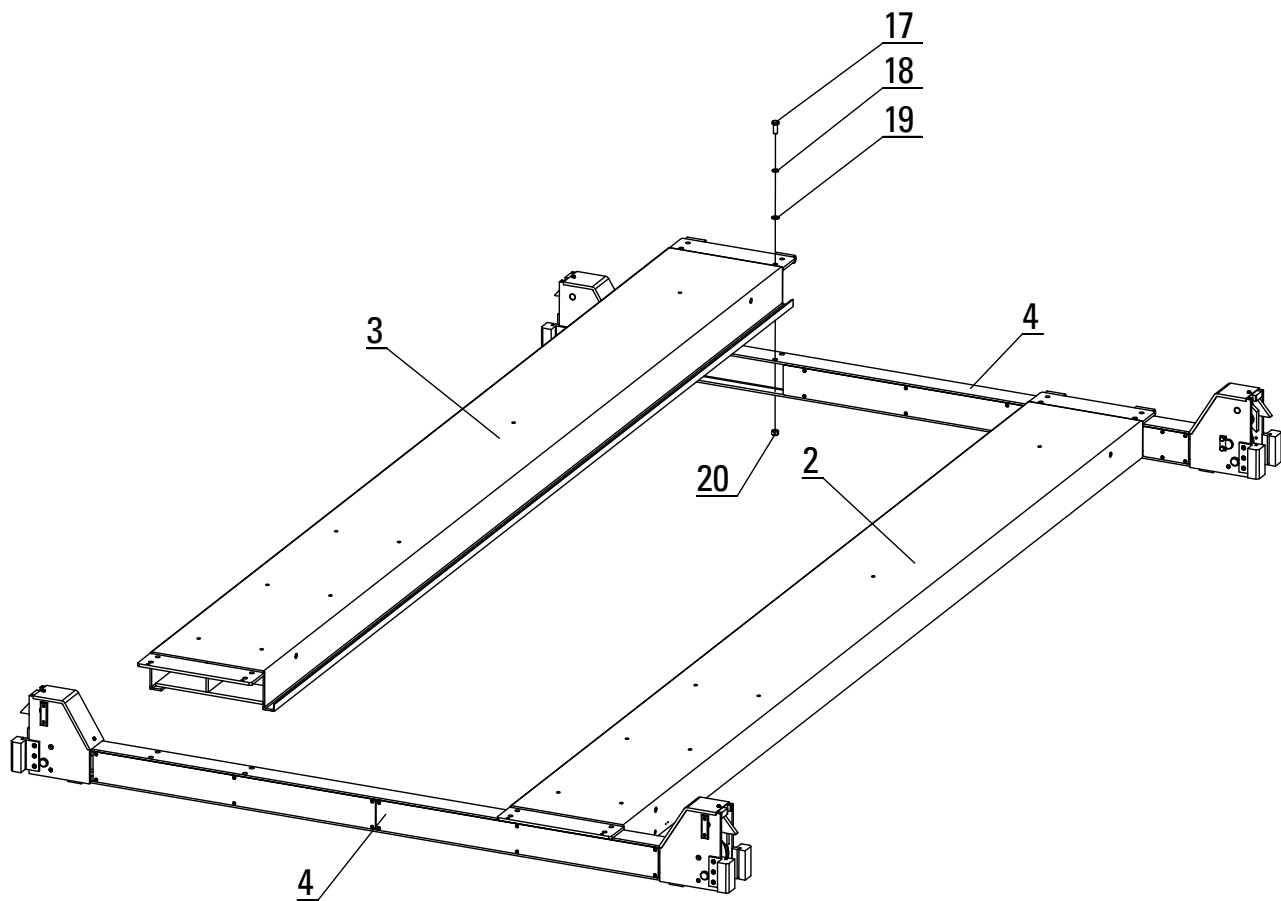

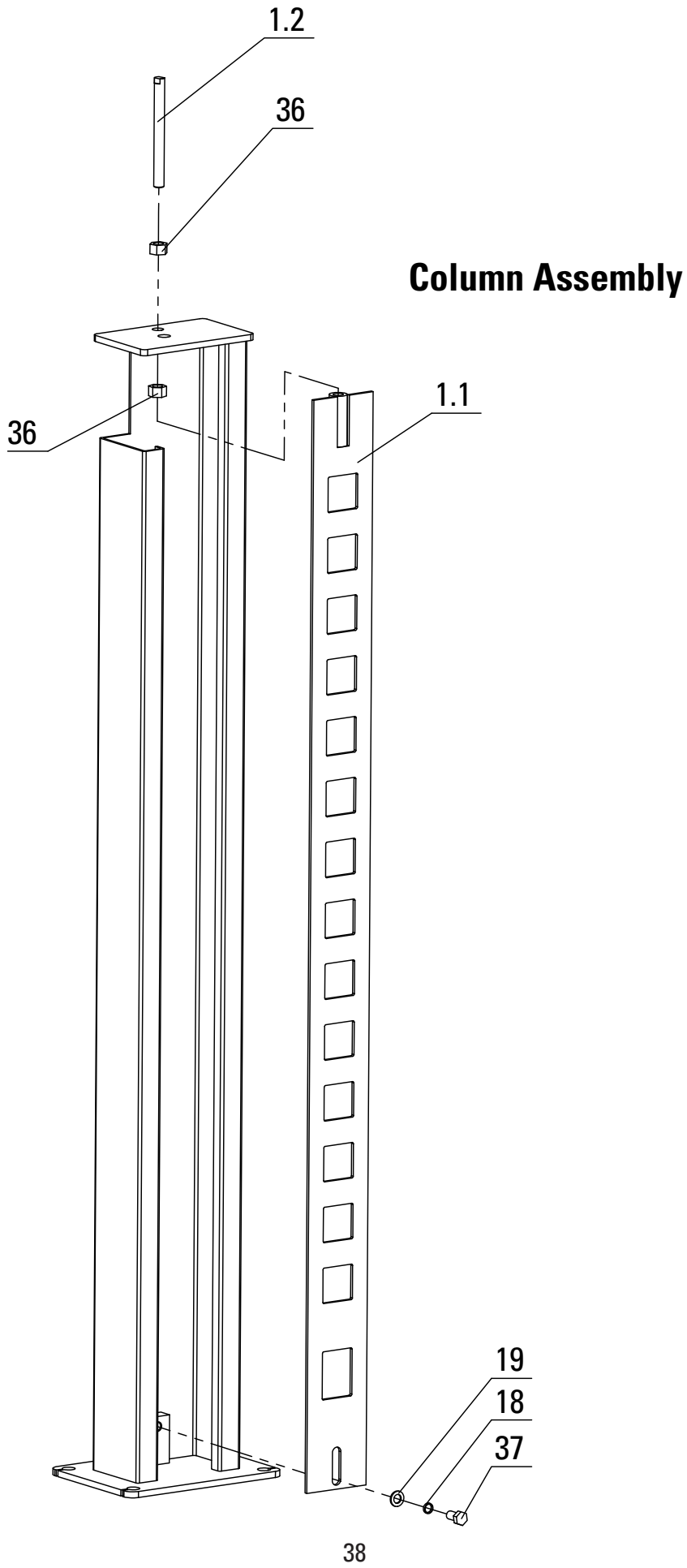

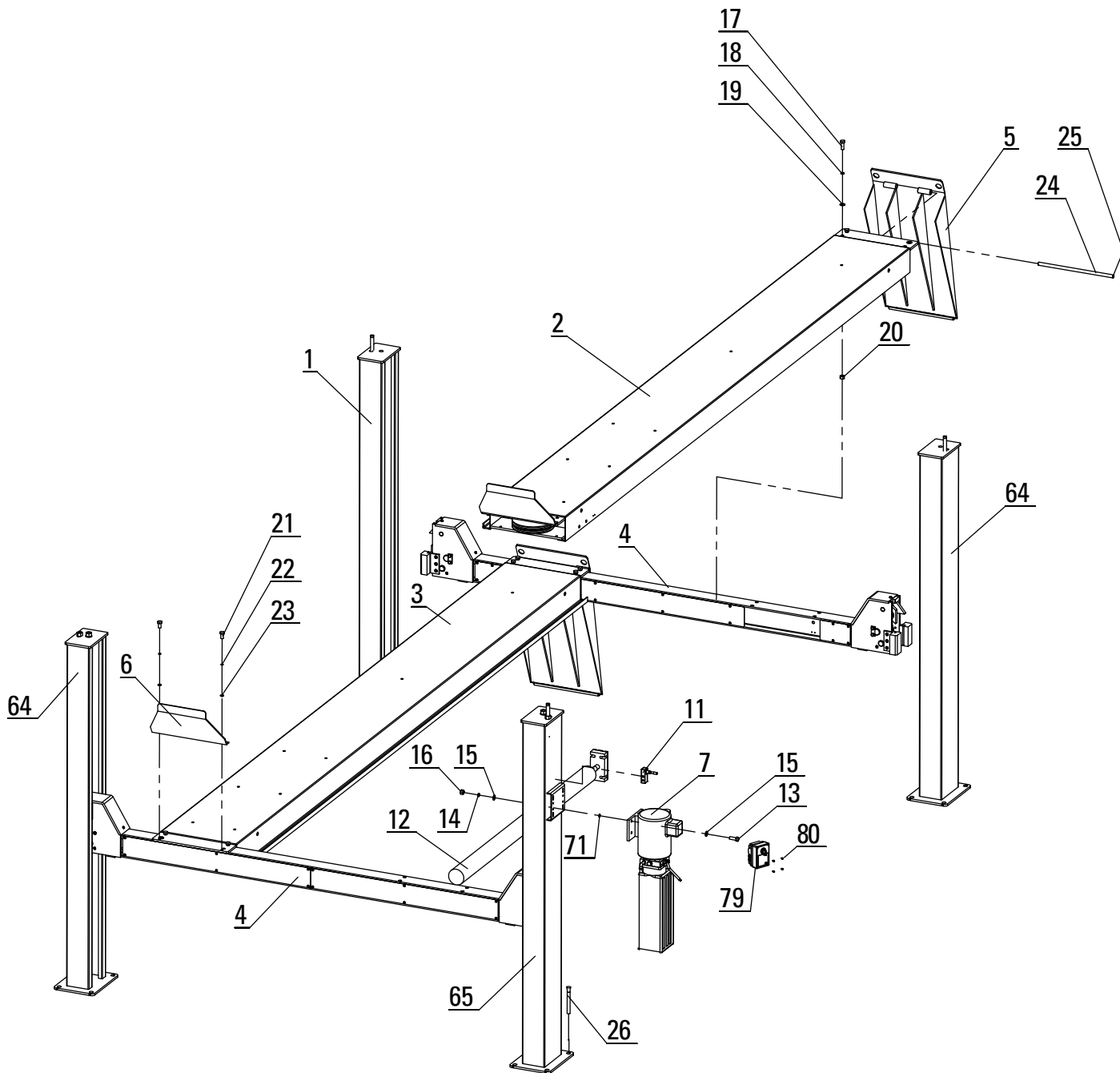

Items	Drawing #	Description	QTY
1	H4P-2100G	Column B	1
1.1	H4P-2300GHJ	Safety Ladder Weldment	4
1.2	H4P-2304	Bolt, Safety Adjustment	4
2	H4P-3000	Runway, Driving Side	1
2.1	H4P-3100	Runway Weldment, Driving Side	1
2.2	H4P-3003	Cable Sheave	6
2.3	H4P-3001	Bearing	4
2.4	H4P-3005	Shaft, Cable Sheave	2
3	H4P-3200	Runway, Slave Side	1
4	H4P-1100G	Cross Beam Weldment	2
4.1	H4P-1157	Cover A	4
4.2	H4P-1159	Cover C	2
4.3	H4P-1158	Cover B	4
4.4	H4P-1001	Top Cover, Cross Beam Ends	4
4.5	H4P-1005	Shaft, Safety Latch	4
4.6	H4P-1009	Shaft, Cable Sheave, Cross Beam Ends	4
4.7	H4P-3006	Locker, Shaft	2
4.8	H4P-1021	Side Block, Cross Beam	8
4.9	H4P-1012	Shaft	4
4.10	H4P-1007	Cable Sheave	4
4.11	H4P-1008	Spacer C	4
4.12	H4P-1016	Connector, Air Cylinder	4
4.13	QG01-9100	Air Cylinder	4
4.14	H4P-1002	Safety Latch	2
4.15	B53-6x22	Ø6 X 22 Pin	8
4.16	H4P-1015	Spring	8
4.17	H4P-1003G	Safety Latch, Slack Cable	2
4.18	H4P-1006	Spacer B	4
4.19	H4P-1011	Spacer	8
4.20	H4P-1004	Spacer A	4
4.21	B30-6	M6 Nut	4
4.22	H4P-1002DC	Safety Latch	2
4.23	H4P-1014	Roll Sleeve	4
4.24	B60-14	Ø14 Snap Ring	4
4.25	H4P-1003DCG	Safety Latch, Slack Cable	2
4.26	B24-5 x 12	M5 x 12 Screw	8
4.28	H4P-1020	Locker, Shaft	4
5	H4P-R2000	Approach Ramp	2
6	H4P-4100	Tire Stopper	2
7	P3517 1Ø	Power Unit	1
	P3518 3Ø		
	P3519 1Ø 50 Hz.		



Items	Drawing #	Description	QTY
8	B23-10 x 20	M10 x 20 Screw	16
9	B30-10	M10 Nuts	16
11	TSV86522S	Air Valve	1
12	YG18-9100G2	Hydraulic Cylinder	1
13	B10-8 x 35	M8 x 35 Bolts	4
14	B40-8	Ø8 Lock Washer	12
15	B41-8	Ø8 Flat Washer	8
16	B30-8	M8 Nuts	12
17	B17-16 x 50	M16 x 50 Bolts, 12.9 Grade	16
18	B40-16	Ø16 Lock Washer	20
19	B41-16	Ø16 Flat Washer	20
20	B31-16	M16 Nuts	16
21	B10-12 x 20	M12 x 20 Bolts	4
22	B40-12	Ø12 Lock Washer	4
23	B45-12	Ø12 Flat Washer	4
24	H4P-4006	Hinge Pin	2
25	B52-3 x 40	Ø3 x 40 Cotter Pin	4
26	B14-3/4 x 140	3/4 x 140 Anchor Bolts	16
27	B23-6 x 10	M6 x 10 Screw	60
28	B41-6	Ø6 Flat Washer	68
29	B60-12	Ø12 Snap Ring	8
30	B24-8 x 20	M8 x 20 Screw	24
31	B10-10 x 20	M10 x 20 Bolt	14
32	B40-10	Ø10 Lock Washer	17
33	B85-6	M6 Oil Zerk	6
34	B21-10 x 16	M10 x 16 Screw	4
35	B52-2 x 25	Ø2 x 25 Cotter Pin	8
36	B30-20	M20 Nuts	8
37	B10-16 x 30	M16 x 30 Bolt	4
38	CH4-2003	Bracket	4
50	H4P-5003	Cable Connector A	1
51	H4P-5004	Cable Connector B	1
52	B41-10	Ø10 Flat Washer	21
53	H4D-Y003	Fitting, Elbow	1
54	B30-30 x 1.5	M30 x 1.5 Nuts	2
55	30400-9053YZ	Fitting, Elbow	2
56	1WB-11	Hydraulic Hose	1
57	1WB-05	Hydraulic Hose	1
58	B41-22	Ø22 Washer	4
59	B-33-22 x 2.5	M22 x 2.5 Lock Nuts	4
60	H4P-5002-2	Cable L= (5559) 219"	1
61	H4P-5002-1	Cable L= (3959) 156"	1

Items	Drawing #	Description	QTY
62	H4P-5002-4	Cable L= (10733) 422-1/2"	1
63	H4P-5002-3	Cable L= (9133) 360"	1
64	H4P-2200G	Column C	2
65	H4P-R1100G	Column A	1
66	B11-10 x 25	M10 x 25 Screw	3
67	H4P-3002	Bracket	1
70	B41-12	Ø12 Flat Washer	4
71	30400-1999	Washer	4
73	H4P-R3100	Wheel Stop	2
74	H4P-R3101	Angle Iron	2
75	H4P-R3102	Rubber	8
76	B23-5 x 16	M5 x 16 Screw	16
77	B41-5	Ø5 Washer	16
78	B30-5	M5 Nut	16
79	FA7366	Drum Switch Box Assembly	1
80	40275	M5 x 10 PHMS, Plated	4



## NOTES